

APPENDIX K

CRANES, DERRICKS, AND HOOKS

FIGURE K-1

MOBILE AND LOCOMOTIVE CRANES

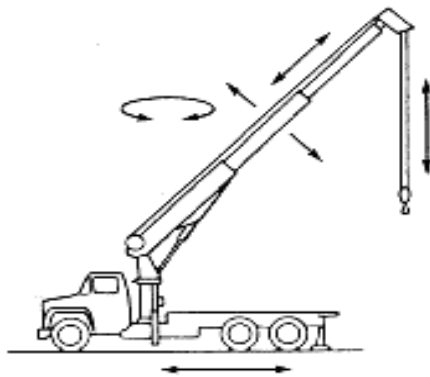

GENERAL NOTE: The boom may have a base boom structure of sections (upper and lower) between or beyond which additional sections may be added to increase its length, or it may consist of a base boom from which one or more boom extensions are telescoped for additional length.

**COMMERCIAL TRUCK-MOUNTED
CRANE — TELESCOPING BOOM**

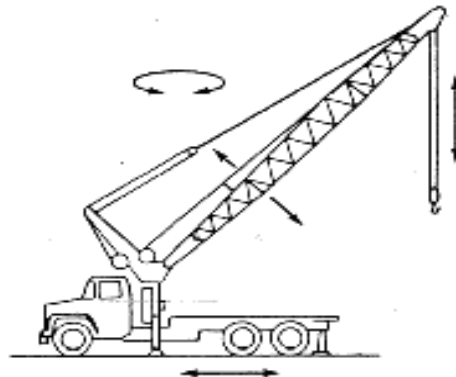

GENERAL NOTE: The boom may have a base boom structure of sections (upper and lower) between or beyond which additional sections may be added to increase its length, or it may consist of a base boom from which one or more boom extensions are telescoped for additional length.

**COMMERCIAL TRUCK-MOUNTED
CRANE — NONTELESCOPING BOOM**

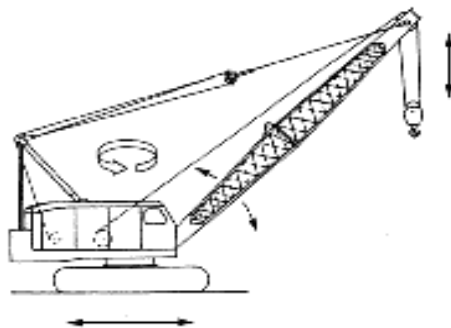

CRAWLER CRANE

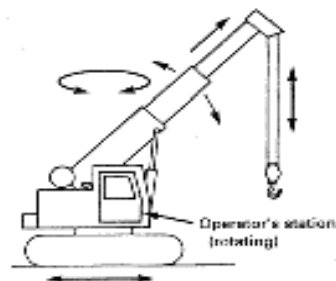

GENERAL NOTE: The boom may have a base boom structure of sections (upper and lower) between or beyond which additional sections may be added to increase its length, or it may consist of a base boom from which one or more boom extensions are telescoped for additional length.

**CRAWLER CRANE
— TELESCOPING BOOM**

FIGURE K-1 (CONTINUED)

MOBILE AND LOCOMOTIVE CRANES

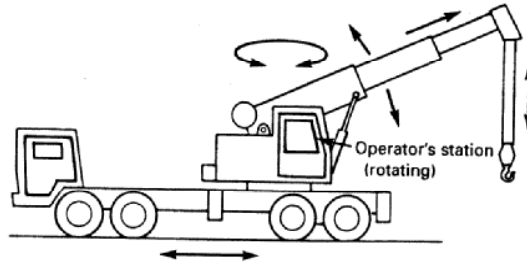

GENERAL NOTE: The boom may have a base boom structure of sections (upper and lower) between or beyond which additional sections may be added to increase its length, or it may consist of a base boom from which one or more boom extensions are telescoped for additional length.

WHEEL-MOUNTED CRANE — TELESCOPING BOOM (MULTIPLE CONTROL STATION)

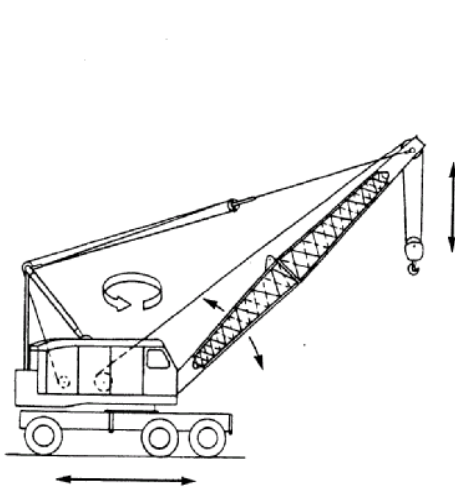

**WHEEL-MOUNTED CRANE
(SINGLE CONTROL STATION)**

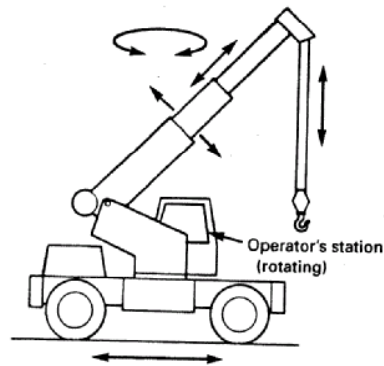

GENERAL NOTE: The boom may have a base boom structure of sections (upper and lower) between or beyond which additional sections may be added to increase its length, or it may consist of a base boom from which one or more boom extensions are telescoped for additional length.

**WHEEL-MOUNTED
CRANE — TELESCOPING BOOM
(SINGLE CONTROL STATION)**

FIGURE K-1 (CONTINUED)
MOBILE AND LOCOMOTIVE CRANES

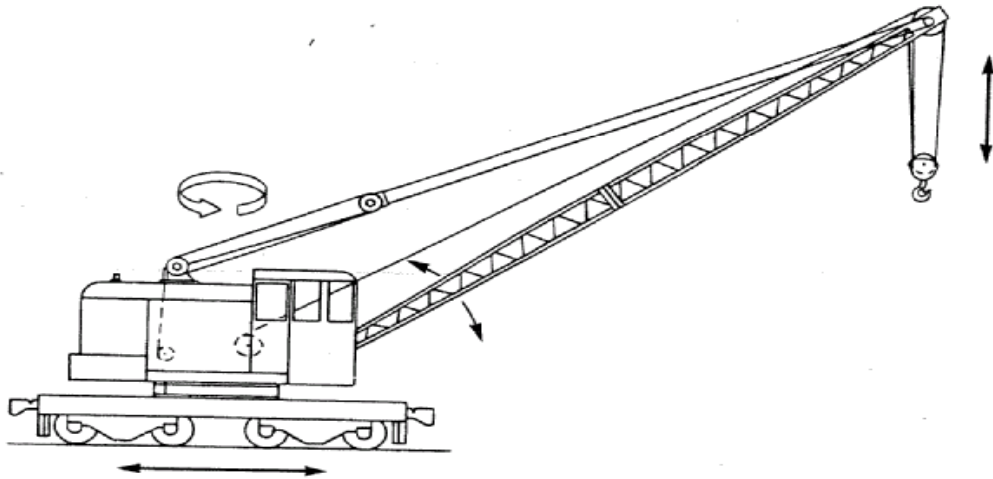

LOCOMOTIVE CRANE

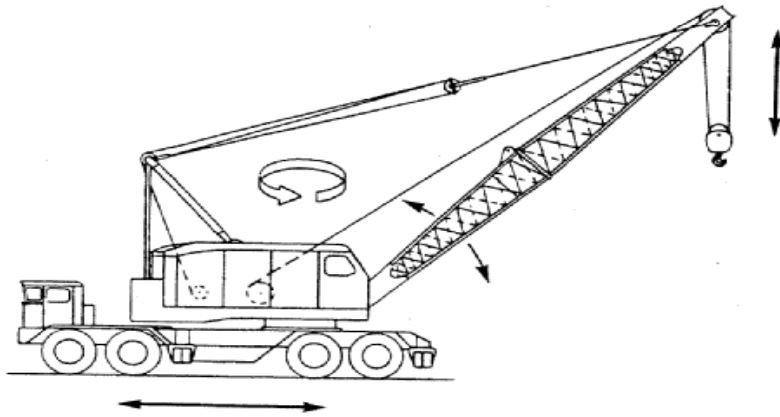

WHEEL-MOUNTED CRANE (MULTIPLE CONTROL STATION)

EM 385-1-1
3 Nov 03

FIGURE K-1 (CONTINUED)

MOBILE AND LOCOMOTIVE CRANES

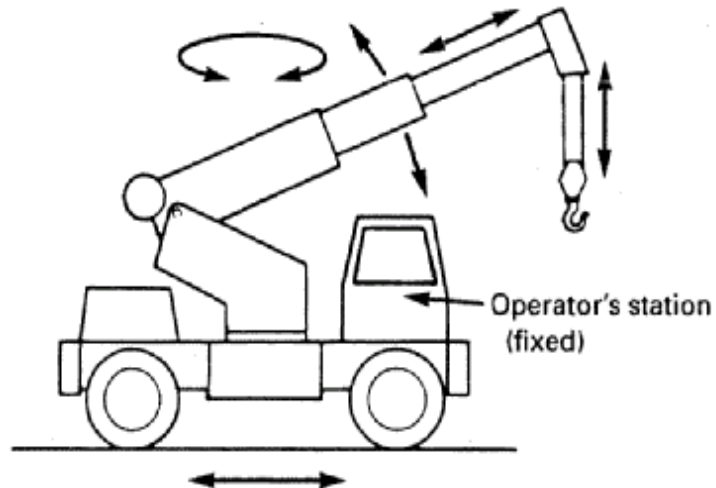

GENERAL NOTE: The boom may have a base boom structure of sections (upper and lower) between or beyond which additional sections may be added to increase its length, or it may consist of a base boom from which one or more boom extensions are telescoped for additional length.

**WHEEL-MOUNTED CRANE —
TELESCOPING BOOM (SINGLE CONTROL STATION)**

FIGURE K-1 (CONTINUED)

MOBILE AND LOCOMOTIVE CRANES

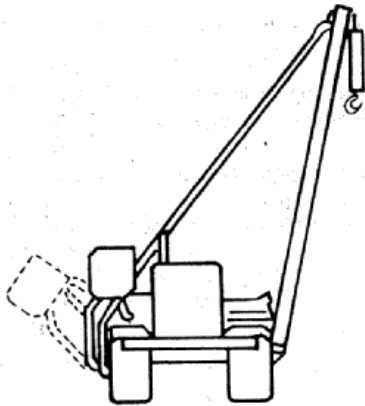

TRACK-TYPE TRACTOR SIDE BOOM

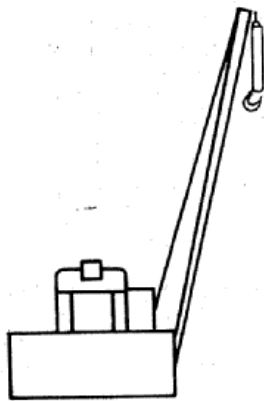
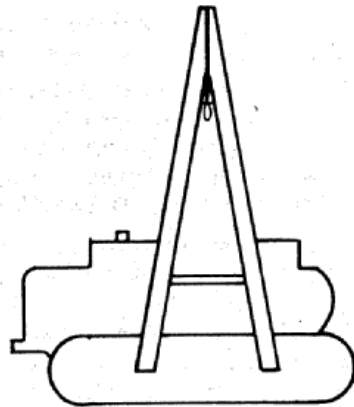

WHEEL-TYPE TRACTOR SIDE BOOM

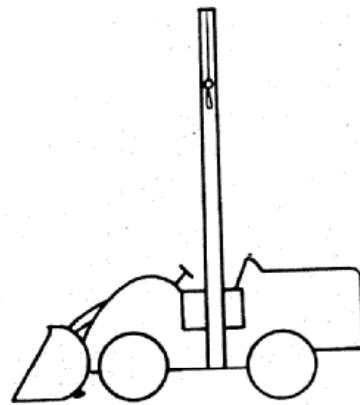

EM 385-1-1
3 Nov 03

FIGURE K-1 (CONTINUED)

MOBILE AND LOCOMOTIVE CRANES

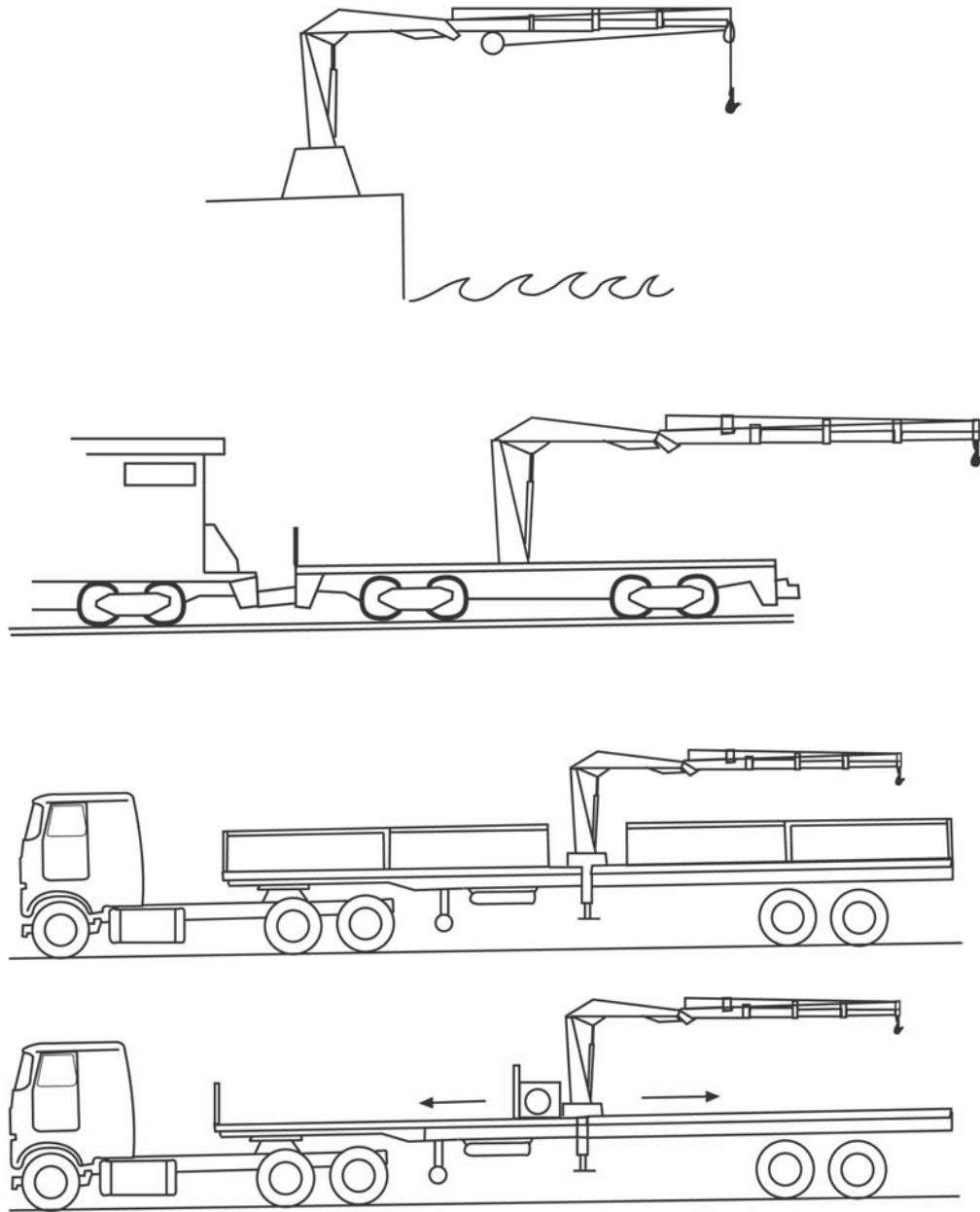
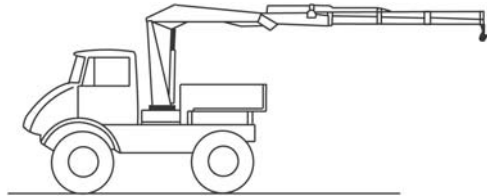
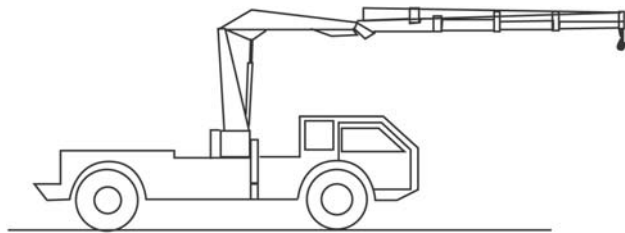

FIGURE K-1 (CONTINUED)

MOBILE AND LOCOMOTIVE CRANES



OFF-ROAD VEHICLE



WHEEL-MOUNTED OFF-ROAD DUAL CONTROL STATION

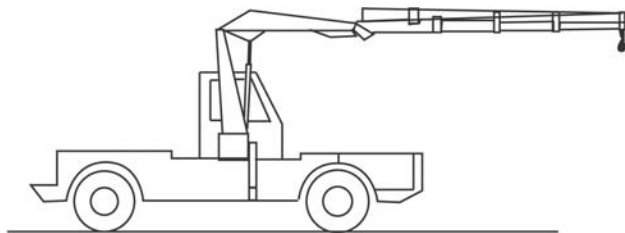

WHEEL-MOUNTED OFF-ROAD SINGLE CONTROL STATION

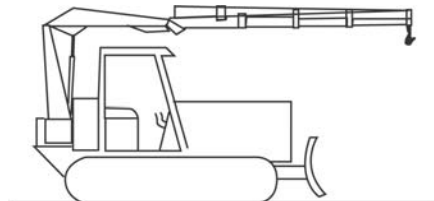

CRAWLER-MOUNTED OFF-ROAD SINGLE CONTROL STATION

EM 385-1-1
3 Nov 03

FIGURE K-2
CONSTRUCTION TOWER CRANES

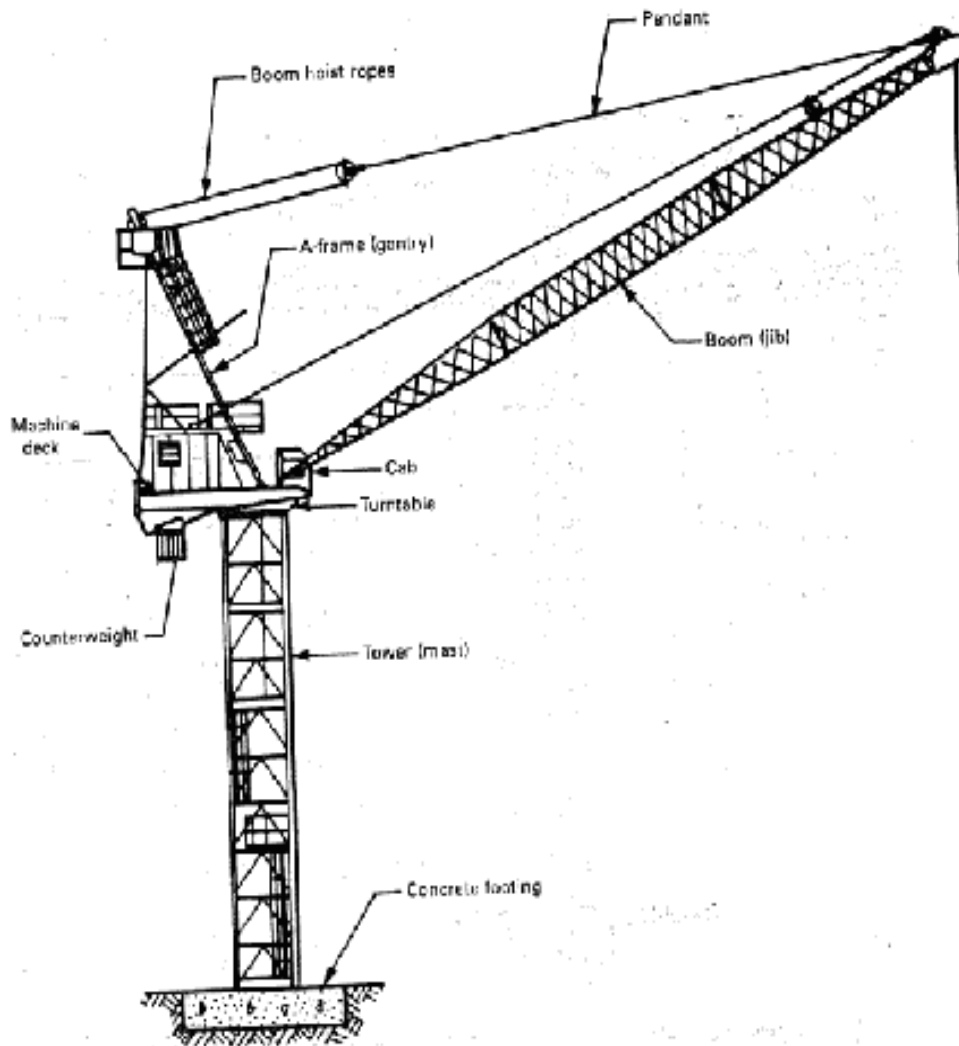

LUFFING TOWER CRANE — STATIC BASE, FREE STANDING CRANE

FIGURE K-2 (CONTINUED)
CONSTRUCTION TOWER CRANES

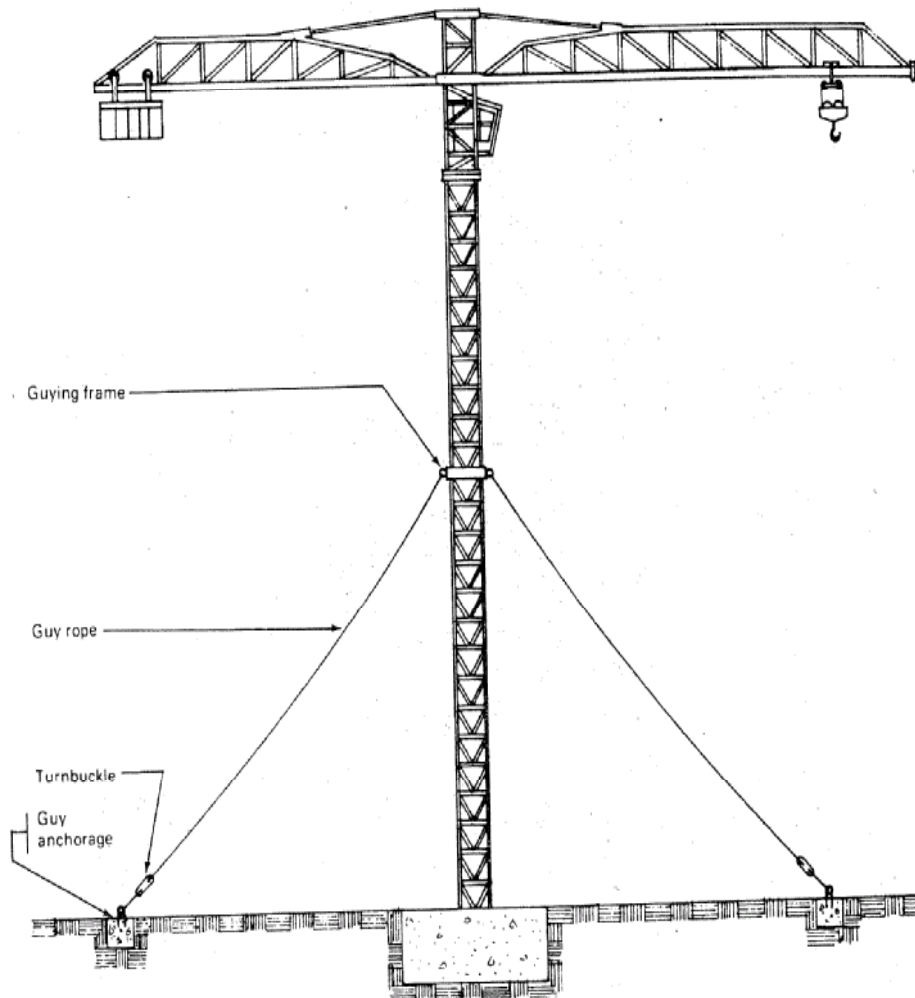

GENERAL NOTE: Three or more guys to be provided, symmetrically arranged.

GUYED TOWER CRANE

EM 385-1-1
3 Nov 03

FIGURE K-2 (CONTINUED)

TOWER CRANES

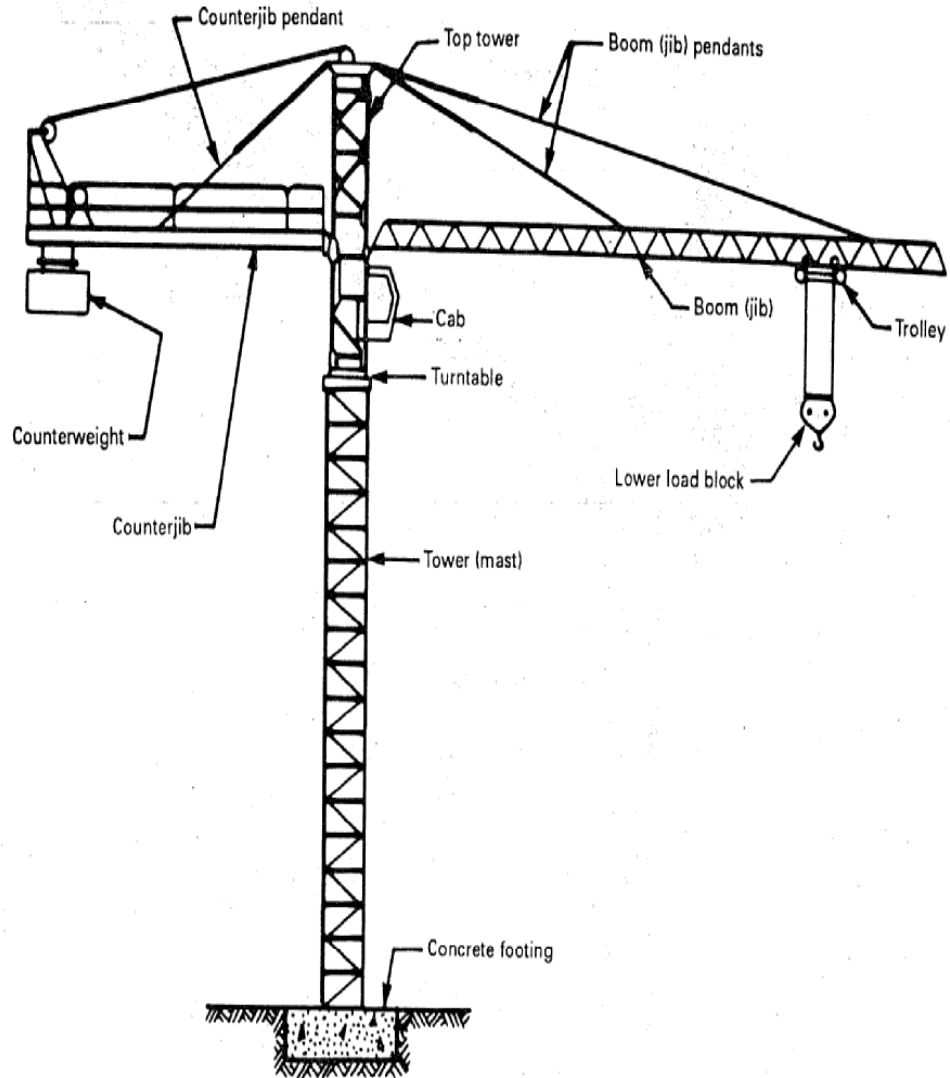

HAMMERHEAD TOWER CRANE — STATIC BASE, FREE STANDING CRANE

FIGURE K-3
OVERHEAD AND GANTRY CRANES

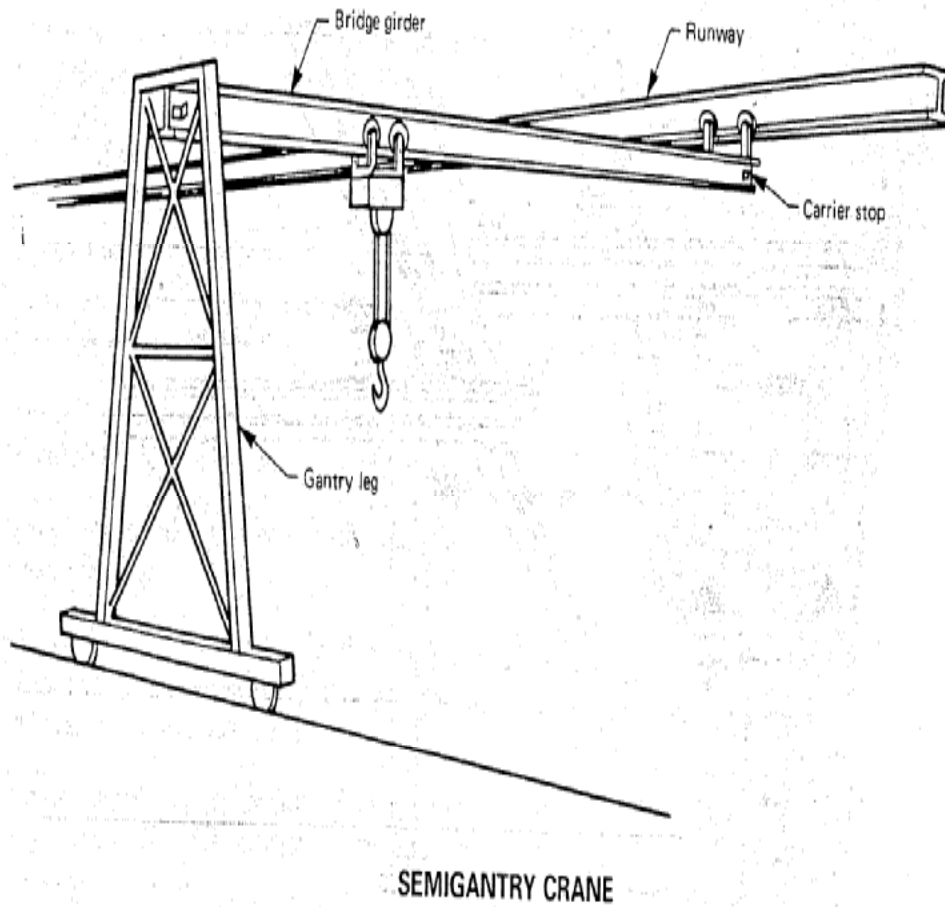

EM 385-1-1
3 Nov 03

FIGURE K-3 (CONTINUED)
OVERHEAD AND GANTRY CRANES

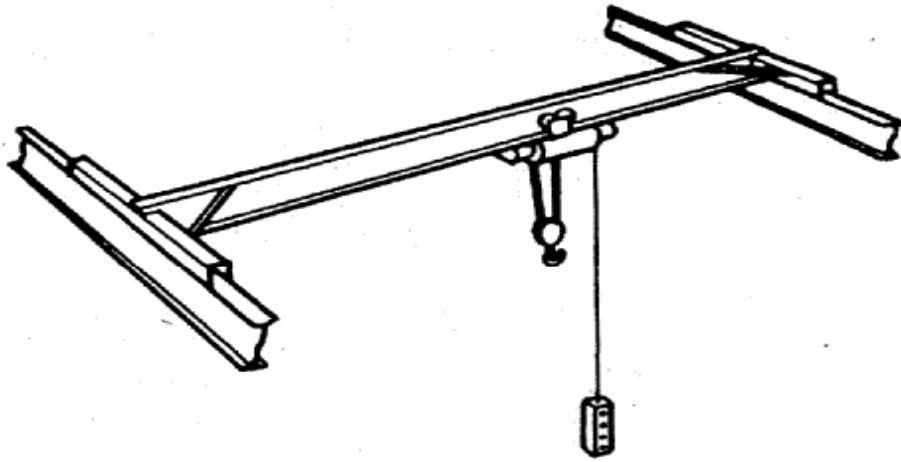

OVERHEAD FLOOR-OPERATED CRANE

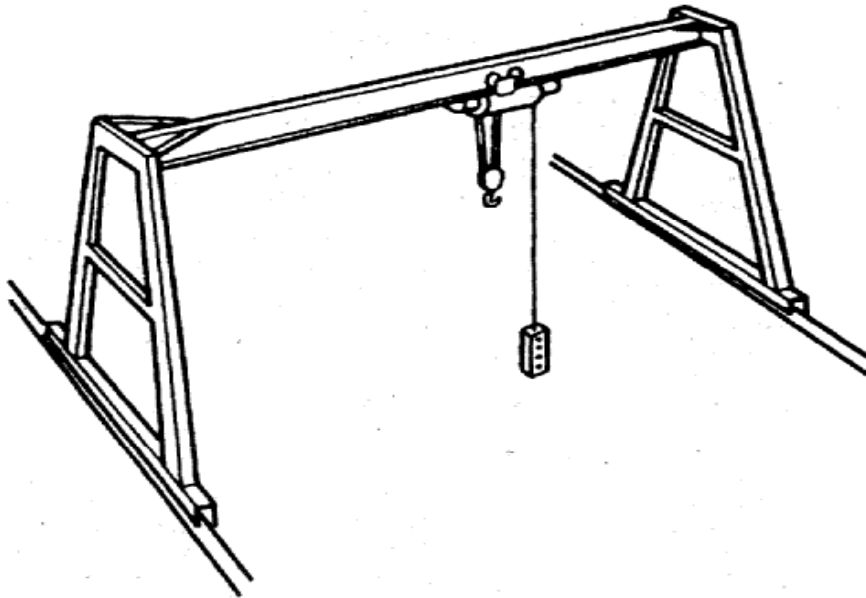

GANTRY CRANE

FIGURE K-3 (CONTINUED)
OVERHEAD AND GANTRY CRANES

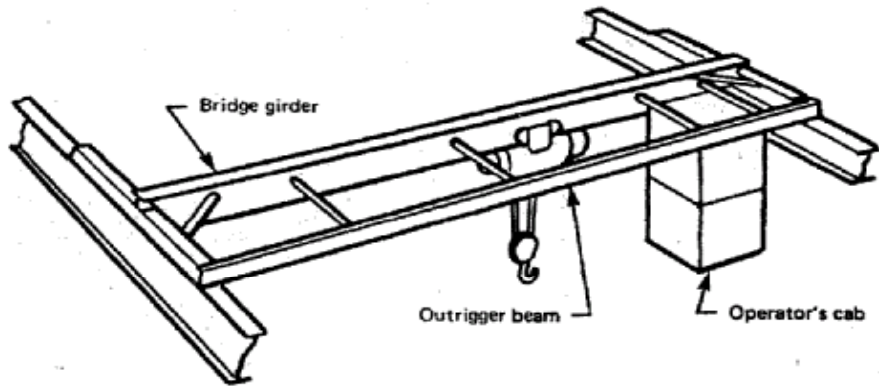

OVERHEAD CAB-OPERATED CRANE

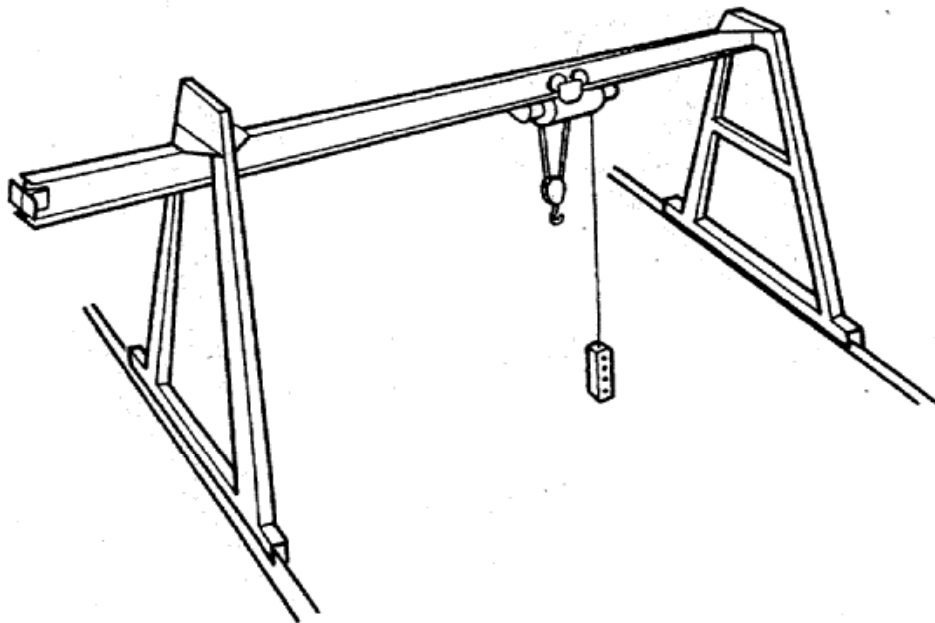

CANTILEVER GANTRY CRANE

EM 385-1-1
3 Nov 03

FIGURE K-4
CAB-OPERATED CRANES

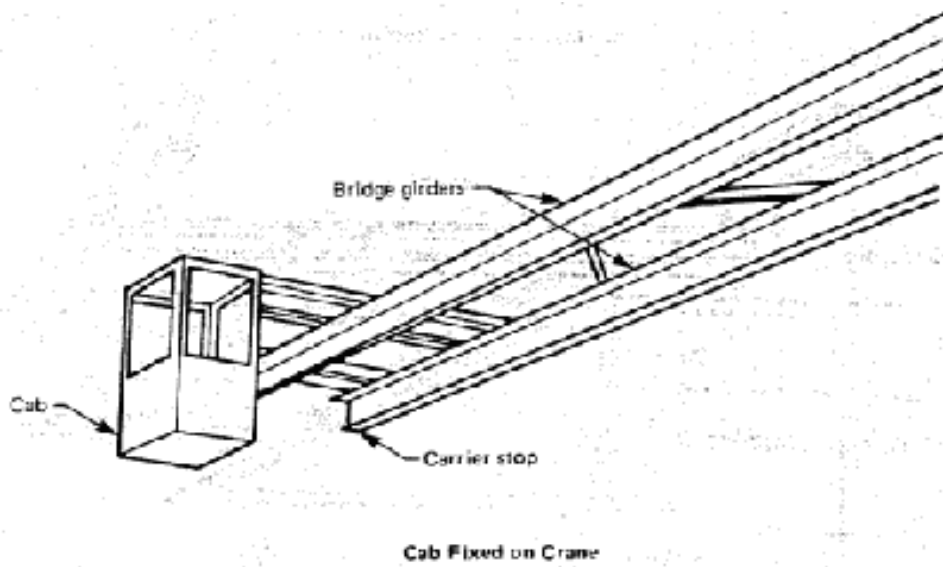
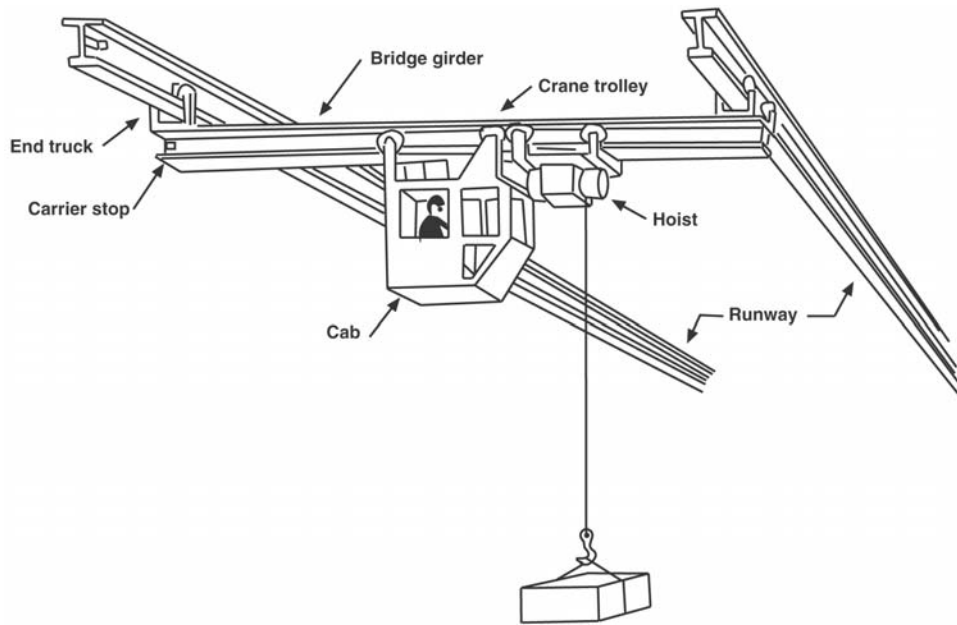
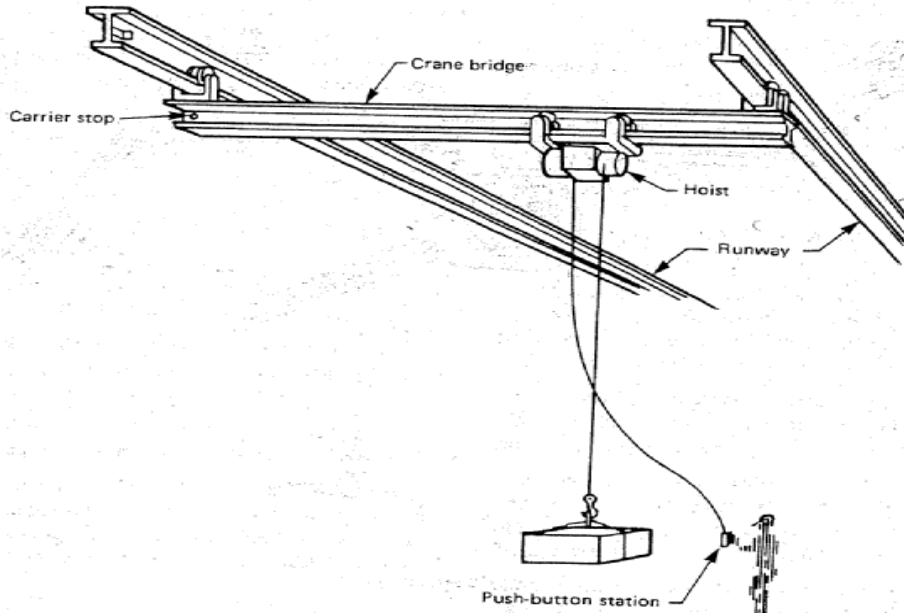
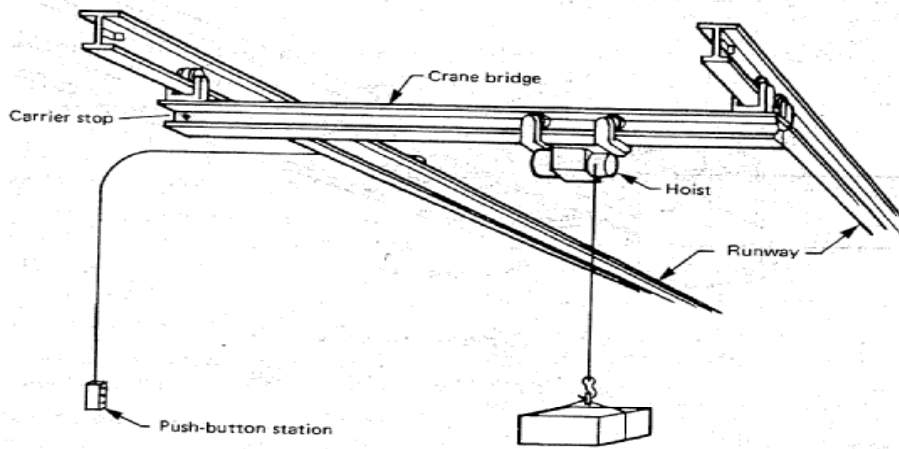

FIGURE K-5
FLOOR-OPERATED CRANES



(a) Hand-Held Push Button



(b) Wall-Mounted Push Button

FLOOR-OPERATED CRANES

FIGURE K-6
FLOATING CRANES

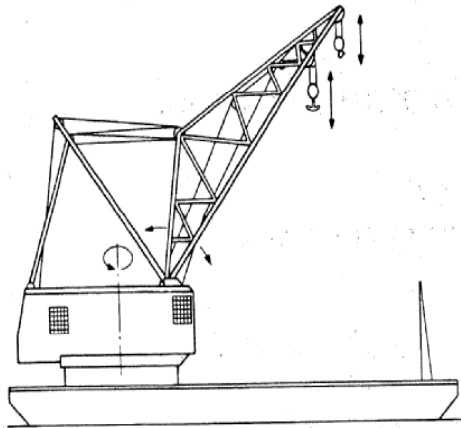

FLOATING CRANE

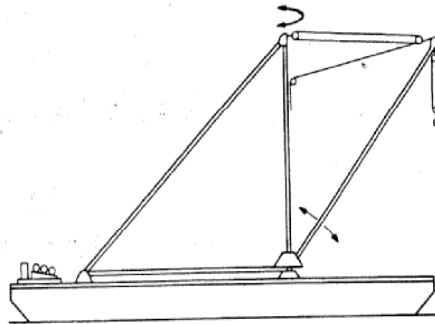

FLOATING STIFFLEG DERRICK

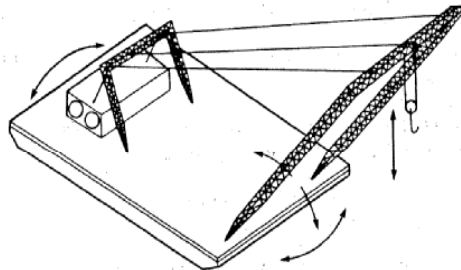

BARGE-MOUNTED SHEARLEG

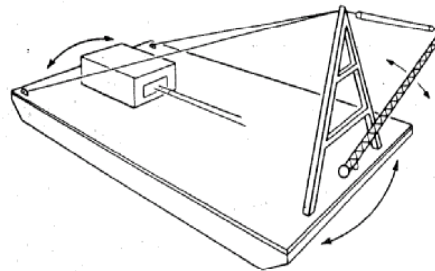

FLOATING A-FRAME DERRICK

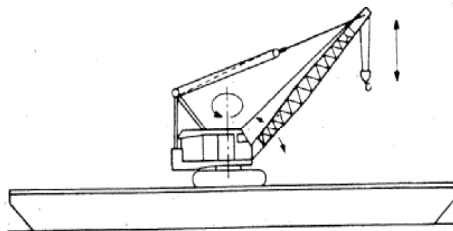

BARGE-MOUNTED LAND CRANE

FIGURE K-6 (CONTINUED)
FLOATING CRANES

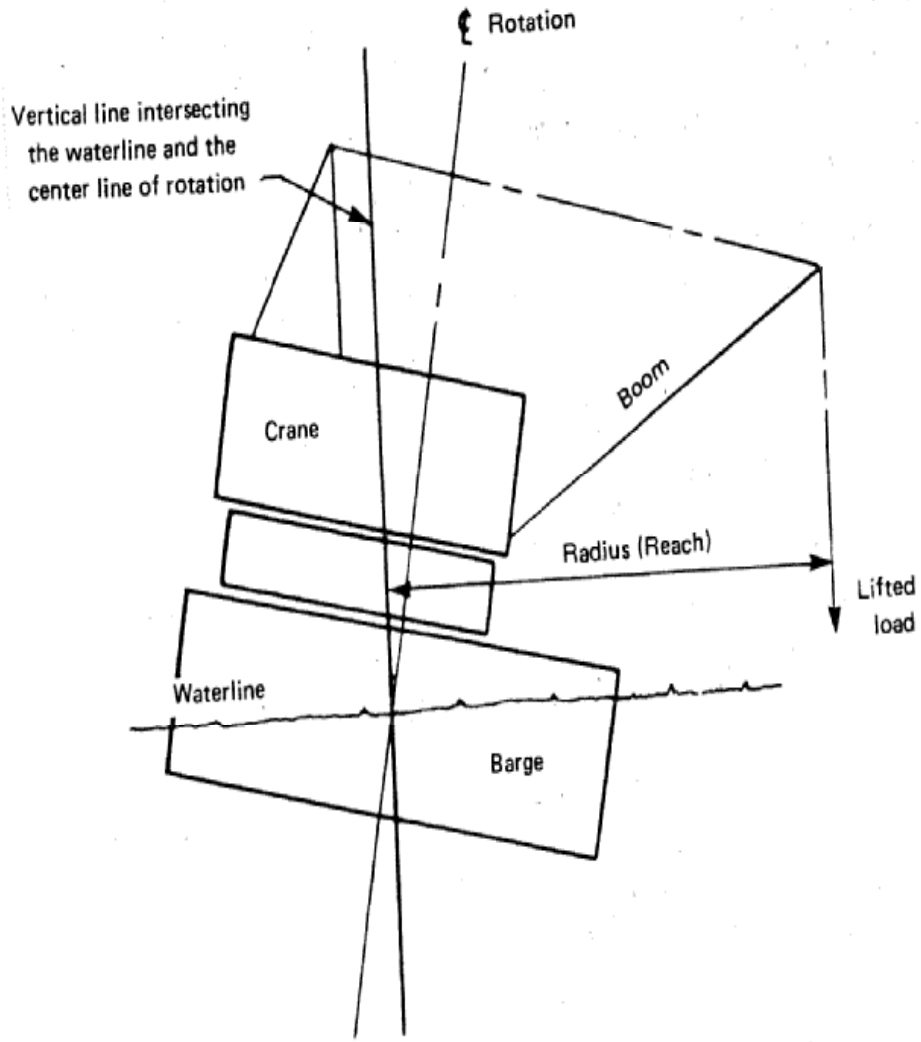

REACH FOR FLOATING CRANES

EM 385-1-1
3 Nov 03

FIGURE K-7
DERRICKS

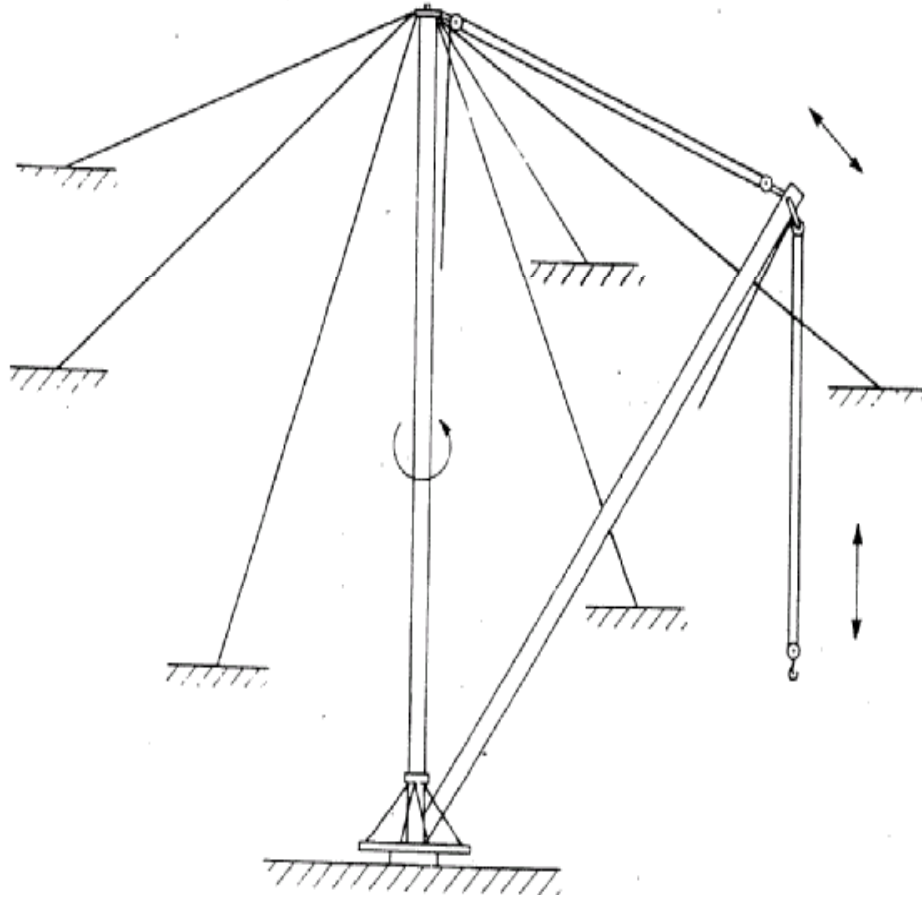

GUY DERRICK

FIGURE K-7 (CONTINUED)

DERRICKS

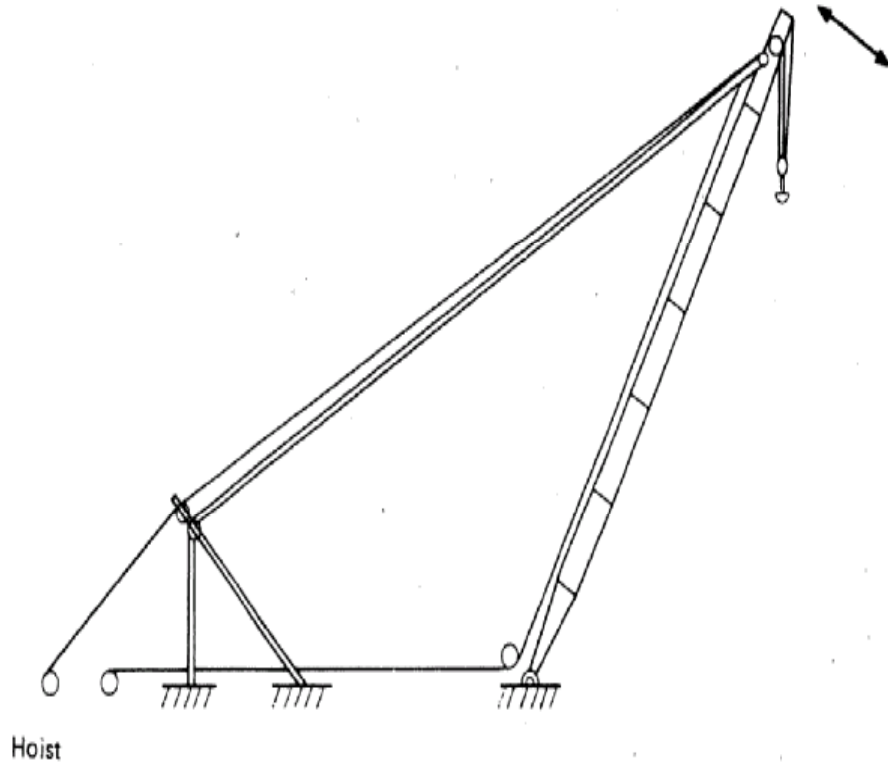

SHEARLEG DERRICK

EM 385-1-1
3 Nov 03

FIGURE K-7 (CONTINUED)
DERRICKS

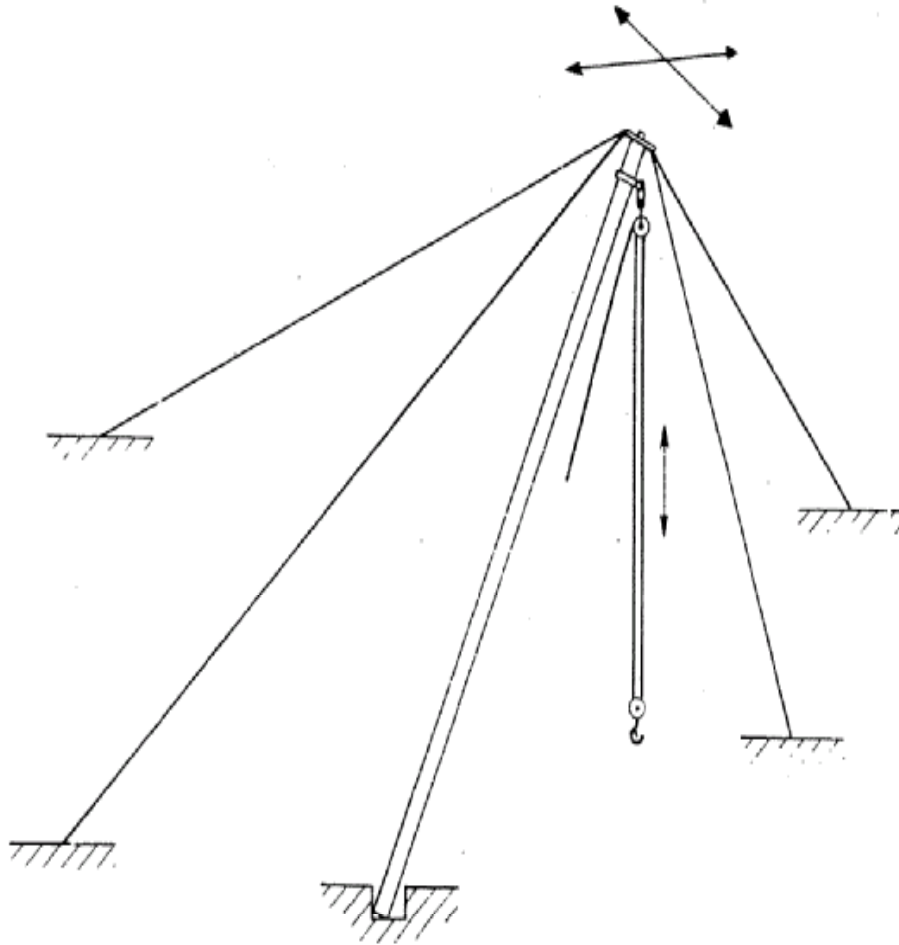

GIN POLE DERRICK

FIGURE K-7 (CONTINUED)

DERRICKS

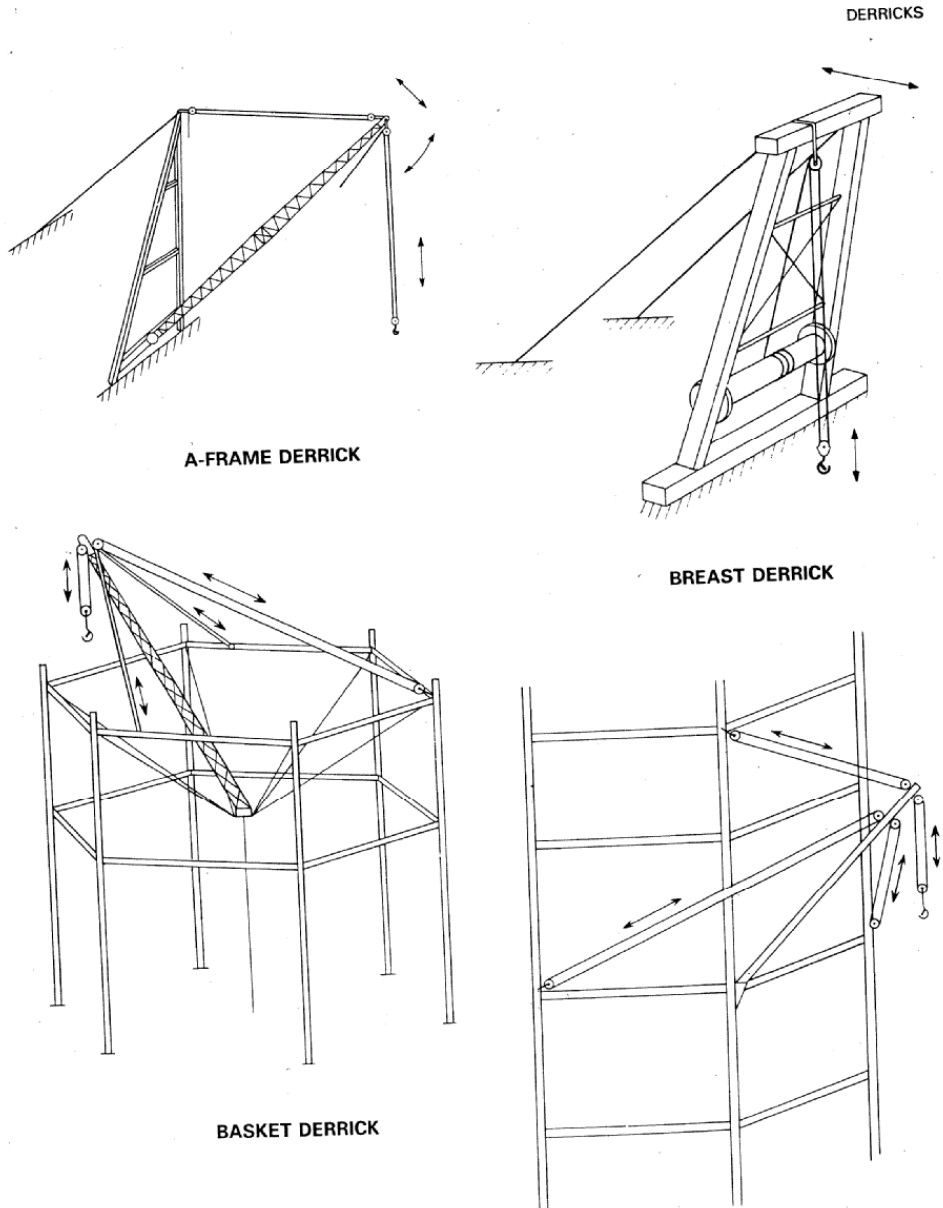

EM 385-1-1
3 Nov 03

FIGURE K-8
DROP SECTION (LIFT SECTION)

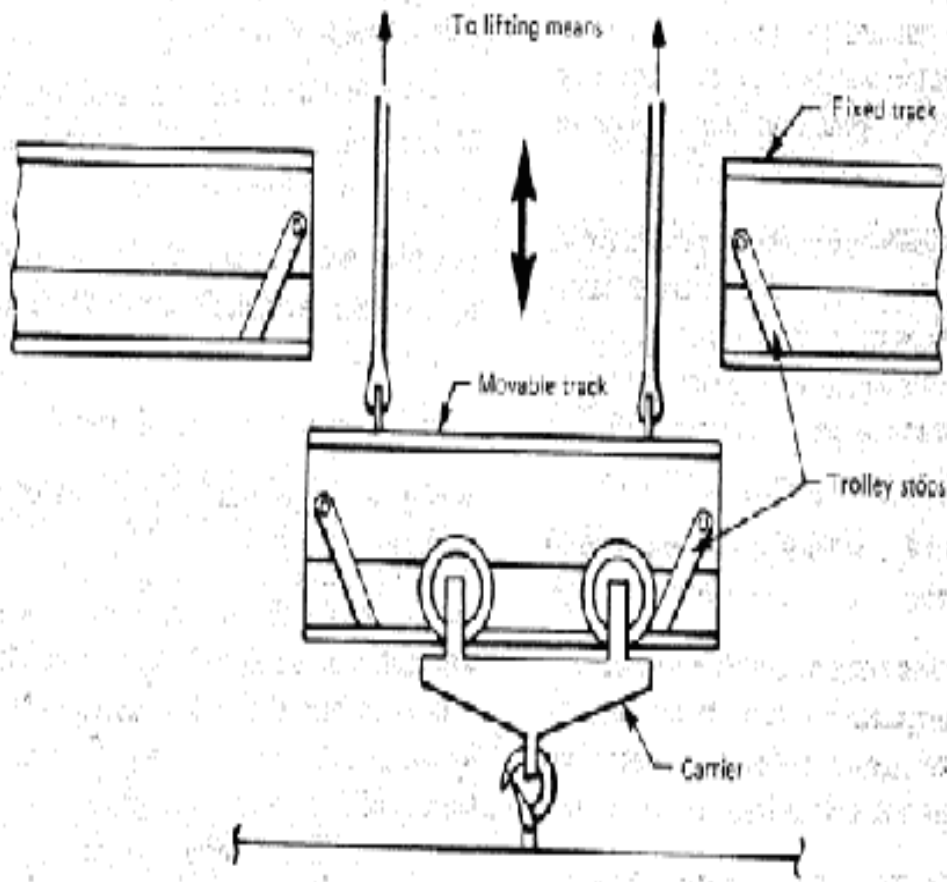
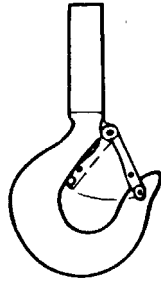

FIGURE K-9
HOOKS



SELF-CLOSING TIPLOCK LATCH (EYE HOOK)



SELF-CLOSING TIPLOCK LATCH (SHANK HOOK)



SELF-CLOSING BAIL (EYE HOOK)



SELF-CLOSING FLAPPER LATCH (SWIVEL HOOK)



SELF-CLOSING FLAPPER LATCH (SHANK HOOK)

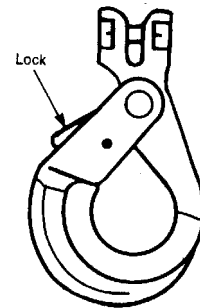

SELF-LOCKING CLEVIS HOOK (CLOSED)

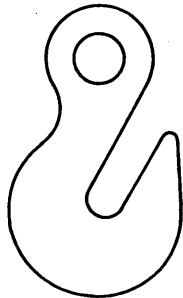

EYE GRAB HOOK

