

CPWR TECHNICAL REPORT

Analysis and Control of Crane and Aerial Lift Hazards

May 2007

Written by David V. MacCollum P.E., CSP

Edited by Rowena Davis

of the

The Hazard Information Foundation, Inc.

Developed by:



THE HAZARD INFORMATION FOUNDATION, INC.
(HIFI)

705 East Wilcox Drive
Sierra Vista, AZ 85635
520.458.6700
besafe@hazardinfo.com

Funded by:

CPWR – The Center for Construction Research and Training
Formerly known as
THE CENTER TO PROTECT WORKERS' RIGHTS

Suite 1000
8484 Georgia Ave.
Silver Springs, MD 20910
301.578.8500

Table of Contents

Acknowledgments

Author's Note

Part I: Abstract

Part II: Equipment Overview

 Five Prominent Hazards

 Powerline Contact

 Overload

 Error Provocative Controls

 Blind Zones

 Inadequate Access

 Other Crane Hazards

 Other Aerial Lift Hazards

Part III: Discussion

 Five Principles of Inherently Safer Design

 Incentives

 Conclusions

Appendix A

Section 1: Powerline Contacts

 (a) cranes

 (b) aerial lifts

Section 2: Upset

(a) cranes
(b) aerial lifts
Section 3: Error-Provocative Controls
(a) cranes
(b) aerial lifts
Section 4: Blind Zones
(a) cranes
Section 5: Unsafe Access
(a) cranes

Appendix B: Other Crane Hazards

Section 1: Crane boom collapse during disassembly
Section 2: Jib stowage
Section 3: Tower crane hazards
Section 4: Bridge crane hazards
Section 5: Self erecting tower crane hazards
Section 6: Killer Hooks
Section 7: Two-blocking
Section 8: Pinchpoint

Appendix C: Other Aerial Lift Hazards

Bibliography

Acknowledgments

The preparation of this research report involved discussion with many of my peers who have been providing expert testimony in crane and aerial lift litigation. Many thanks go to Ben Lehman, a retired Navy admiral, an engineering officer and licensed engineer who is extremely knowledgeable in metal failure modes. Richard Hughes, PE, with a Bachelors' of Science in civil engineering and Masters' degree in engineering science from Pennsylvania State University, has used his twenty years of experience to be exceedingly helpful with his intimate knowledge of the role of cranes and aerial lifts in the erection of 38-story buildings and bridges exceeding 1000-foot spans. Jim Lapping, PE, who has investigated and testified on the practice of stowing jib booms on mobile hydraulic telescoping boomed-cranes, has provided collaborative viewpoints concerning needed safety features. Dr. Lorna Middendorf, PE, a nationally recognized authority on human factors, has validated issues concerning human factors. George Peters, PE, author of the book *Human Error: Causes and Control* (a CRC Taylor and Francis publication), has for years been a supporter of the need to ensure that design of equipment controls is not error-provocative. Both Bill English, PE, and Nigel Ellis, PE, have over many years been leaders in pedestrian slip resistance and fall prevention. Jack Ainsworth, an electrical engineer, has long been a voluntary contributor of his expertise regarding the science involved in the detection of powerlines by proximity alarms. The observations of Mike McCann, safety director for The Center to Protect Workers' Rights (CPWR), have provided insight to a number of hazards involving both cranes and aerial lifts. The dedication and work by all these individuals has contributed both to the research presented in this study and to the progress in the field of workplace safety.

The funding provided by The Center to Protect Workers' Rights (CPWR) for this research paper has provided the opportunity to summarize the experience of safety professionals in construction. With this funding, HIFI was able to assemble many viewpoints for consideration and to select the most

effective measures of hazard prevention from the myriad of expert opinions offered by so many talented engineers and safety professionals. Many and continued thanks to this worthy organization.

The observations presented in this study involve long-standing and valid opinions of Dennis Eckstine, a mechanical engineer who has for years been the safety director for Grove Cranes. For a research paper to be valid, differing concepts concerning how crane and aerial lift hazards can be best controlled must be taken into consideration.

The most important contributor to this research paper is Rowena Davis, HIFI's editor and hazard analyst. It is a truism to say that engineers do not know how to write. Rowena has provided an outstanding and essential contribution to the study by ensuring that "English is written." I can personally say that in many instances ideas apparent to my mind are confusing to the reader. Research of hazards and their control by the use of appliances or alternate, safer design is a very difficult subject for many reasons, and requires a very thoughtful clarity for all readers. Thanks again to Rowena.

David V. MacCollum PE CSP

May 2007



Author's Note

After thirty-five years of examining third-party personal injury litigation and reviewing the statements of witnesses who were questioned as to the cause of a particular crane or aerial lift injury, I have observed a striking pattern of seeing the injured victim identified as the principal cause. However, analysis of the occurrence often shows that the ultimate cause was a hazardous condition or an equipment defect due to absence of a safety appliance or alternate, safer design. The blame then shifts from the victim to other parties. When there is some evidence of management neglect, the investigation's focus begins to explore many irrelevant issues, as every party wishes to defend themselves against liability. After a number of similar injury occurrences from the same hazard and the development of standards, rulemaking, legislation, and litigation begins, the process turns into a cycle where every party desires to avoid responsibility. Most of them fail to recognize that each of them has some ability to control the hazard and avoid incidents.

Such refusal of responsibility leads to a society that has become polarized on safety issues. One needs to step back and develop an awareness of the humor that reality presents. I often turn to Letterman's "Late Show" and appreciate how he uses humor to overcome ridiculous reasoning. Today's industry appears to have spent a great deal of effort and money to ensure that

the national safety climate relies upon an inefficient system rather than hazard prevention measures. Without pointing to any one entity, debate responding to rulemaking for prevention of a hazard often leads to the following exercise in futility:

1. Conduct a survey to make sure that everyone agrees that a hazard exists.
2. Contact the skeptics and let them dominate the hazard assessment.
3. Consider the hazard to be inconsequential and not a danger to most people, as any injuries are usually the fault of the victims.
4. Recognize that safety appliances or design improvements will cost money.
5. If it is found that the cost of injury is greater than the cost of the safety feature, repeat steps 1-4.
6. Investigate who will have to pay for the safety feature.
7. Assert that the safety feature will fail and injure more people than the hazard itself.
8. State that, despite overwhelming evidence to the contrary, there will be a costly lawsuit if the safety feature or alternate safer design fails.
9. Look to the business community to publicly announce that safety appliances, alternate safer designs, or control measures are unreliable.
10. When legislation is pending to control a hazard, secure a national safety organization to testify against its enactment*.

* *Engineering News Record* April 23, 2007, "Crane Safety" page 14. A nationally known safety professional organization voiced opposition concerning the state of Washington's new law requiring crane operators to be certified by a nationally accredited agent and cranes inspected annually by a third party before and after set-up by stating that the state should wait for less stringent Federal compliance standards to be enacted. Washington's law is similar to one recently enacted in California.

Hopefully with this satire on human nature the research study will present some engineering approaches where safety by design can give meaning to the sound-bite, “To err is human; to forgive, design.”



Analysis and Control of Crane and Aerial Lift Hazards

Part I

Abstract

Controlling hazards inherent to cranes and aerial lifts requires the adoption of available technology, in addition to conventional processes of injury prevention such as safe work practices and personal protective equipment. Today's construction and maintenance methods depend on very complex construction equipment. Focus on these machines reveals that they must be viewed as a system comprised of structural, mechanical, and electrical components that must all function safely for optimal use. The primary value of the family of machines encompassing cranes and aerial lifts is their great utility in the workplace, but their designers and supervisors often erroneously assume that user/operator performance will always be reliably uniform and without error. It is a fantasy to assume that the user/operator can reliably overcome error-provocative design defects. Therefore, these machines must be made safe for their intended use and foreseeable misuse. This paper expands upon the 1993 book *Crane Hazards and their Prevention*¹ to examine some of the major hazards on cranes and aerial lifts and evaluate methods of control using safety appliances and/or alternate safer design. Specific examples will show how the

¹ *Crane Hazards and Their Prevention*, MacCollum, first published by the American Society of Safety Engineers (ASSE), 1993. Updated edition published in 2005.

application of engineering principles can eliminate or minimize many inherent hazards.

Implementation of engineering solutions to control crane and aerial lifts hazards requires a two-faceted approach. First, engineers must develop a methodology of hazard identification and control so engineering solutions can be incorporated into the design of equipment. The Five Principles of Inherently Safer Design[~] is a method to identify hazards in a variety of contexts and design them out during the initial phase of product development. Product design must be examined for all potential hazards to maximize opportunity to add features that prevent injury.

Second, equipment designers, manufacturers, and rental agencies must collaborate with other interests in the construction industry. Multi-party discussion of requirements and potential uses of equipment leads to innovation in design and ideas for new technology. When this collaboration is applied to safety, relevant and cost-effective safer design and safety appliances on equipment can emerge. Examination and control of hazards in the design stage is an important component of “Progressive Project Delivery” (PPD), a construction method based on the collaboration of owners, designers, estimators, and construction managers during the initial stages of a project. This method makes decisions based on multiple sources of input and is usually more efficient and cost effective

[~] Research Report: “Inherently Safer Design Principles for Construction, August 2005, completed by the Hazard Information Foundation, Inc (HIFI), funded by the Center to Protect Workers’ Rights (CPWR). It is now published in a desk reference entitled *Construction Safety Engineering Principles: Designing and Managing Safer Job Sites* by McGraw Hill, January 2007. To purchase or for more information visit www.mhprofessional.com under the construction heading.

than traditional design-bid-build methods. PPD is more thoroughly examined in Part III.

Business concerns of a large portion of the construction industry must register an immediate gain by investing in the development or use of safety appliances and alternate safer design. When different interests within a construction project pool their knowledge to maximize individual gain, the result is usually a project with fewer costs and integrated safety solutions. Our American workforce should never be sacrificed due to use of dangerous equipment. Collaboration between parties on integration of safety into project design makes achievement of zero injuries possible.



Part II

Equipment Overview

Cranes and aerial lifts are made in a variety of models.

See Illustrations 1-10 for cranes.

Cranes

Illustration 1² Latticework boom cranes

Latticework Fixed-Boom Crane

Mounted on Truck, Rails, or Crawler

1. Cab
2. Boom Stops
3. Hoist Line
4. Headache Ball
5. Hoist Line Block
6. Anti-Two-Blocking Sensor
7. Boom Pin-Up Guys
8. Linkage Suitable for Shorter Boom Lengths
9. Linkage Suitable for Shorter Boom Lengths
10. Linkage Suitable for Shorter Boom Lengths
11. Removable Boom Section
12. Counter-weight
13. Outriggers
14. "A"-frame

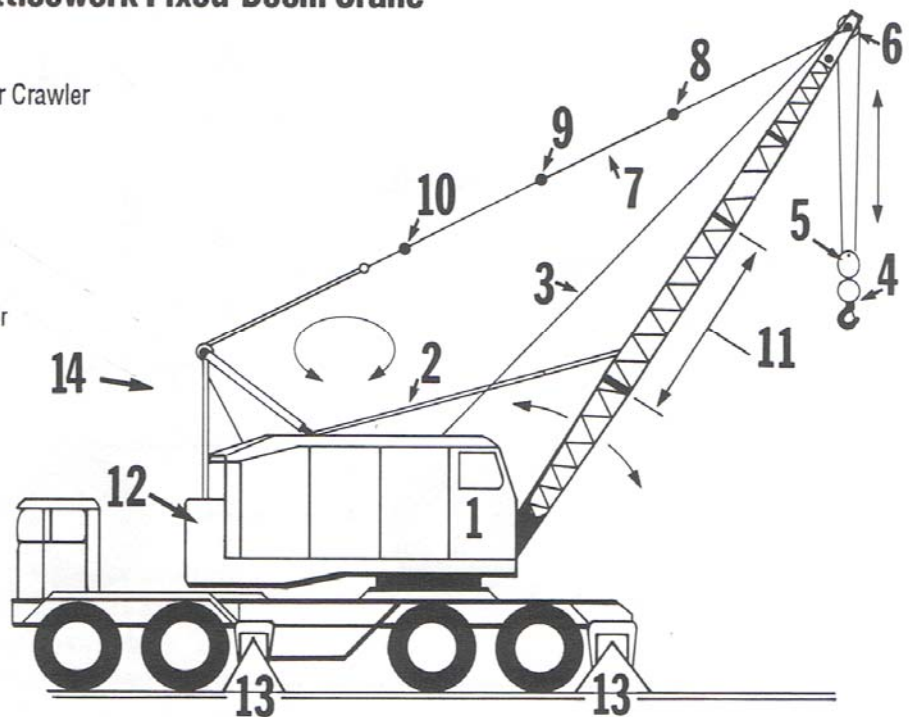

² All crane images reproduced from *Crane Hazards and Their Prevention*, David MacCollum, American Society of Safety Engineers, 1993, which obtained permission for use of these illustrations from the American National Standards Institute (ANSI).

Illustration 2 Hydraulic telescoping boom cranes

Rough terrain

Telescoping Boom Mobile Hydraulic Crane

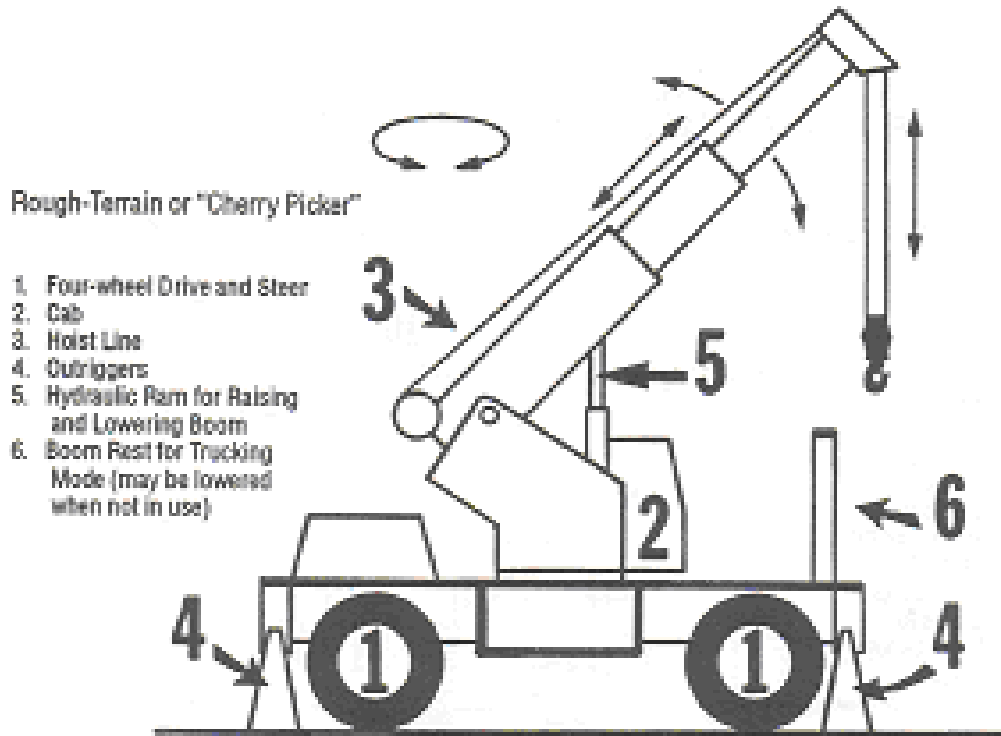

¹ Pertinent ANSI standards provide additional detailed illustrations of the various crane configurations.

Illustration 3 Truck-mounted

Truck-Mounted Hydraulic Boom Crane

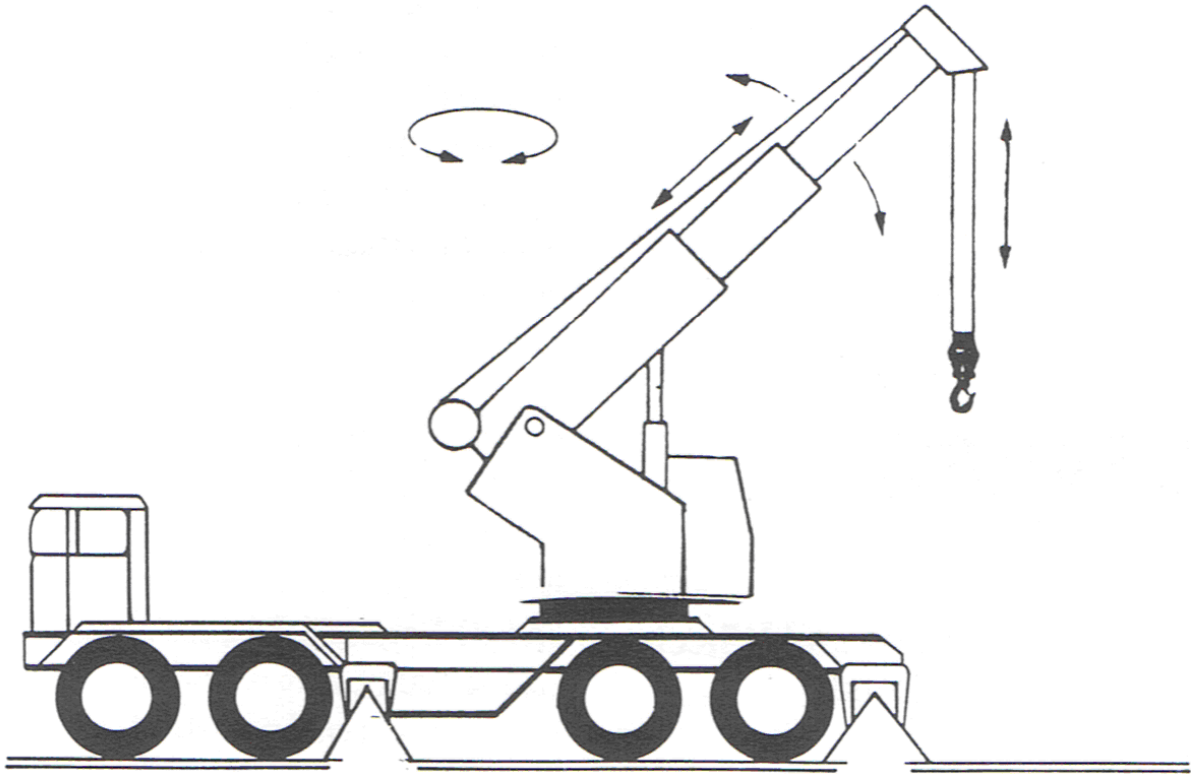

Illustration 4 Flatbed pedestal

Pedestal Hydraulic Boom

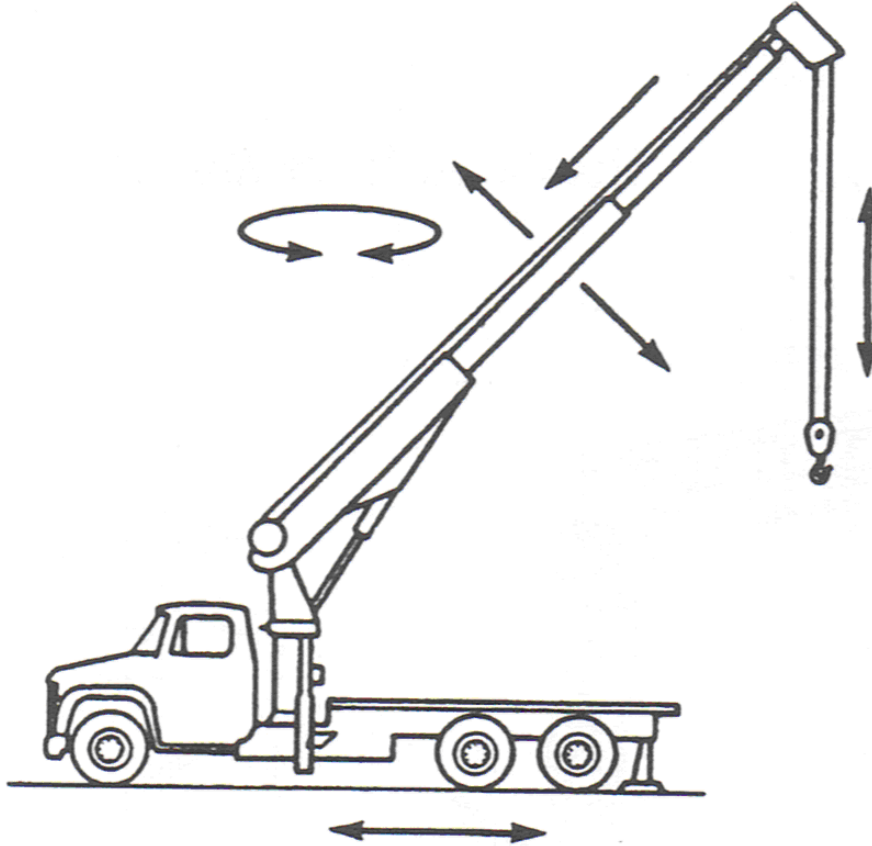
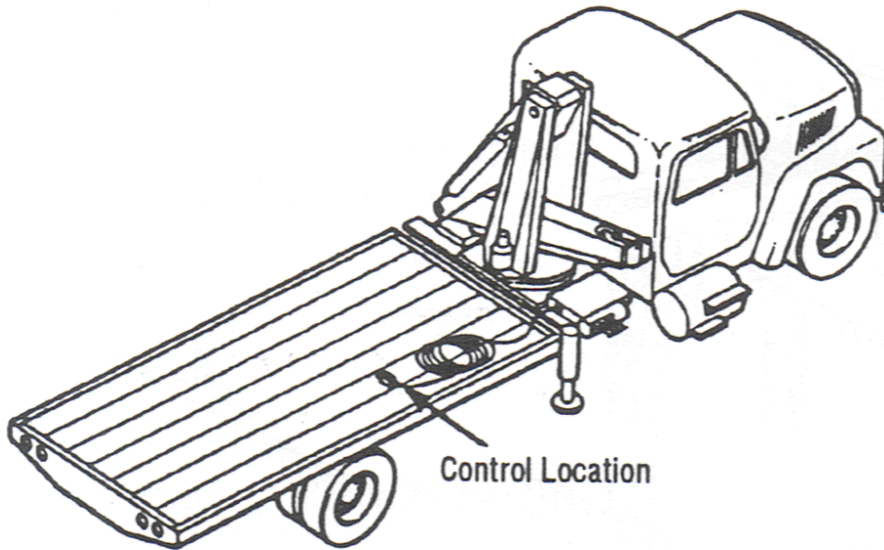

Illustration 5 Articulate boom cranes

Articulated Boom



ANSI B30.22-1981
Authored by ASME

Illustration 6 Trolley boom cranes

Trolley Boom

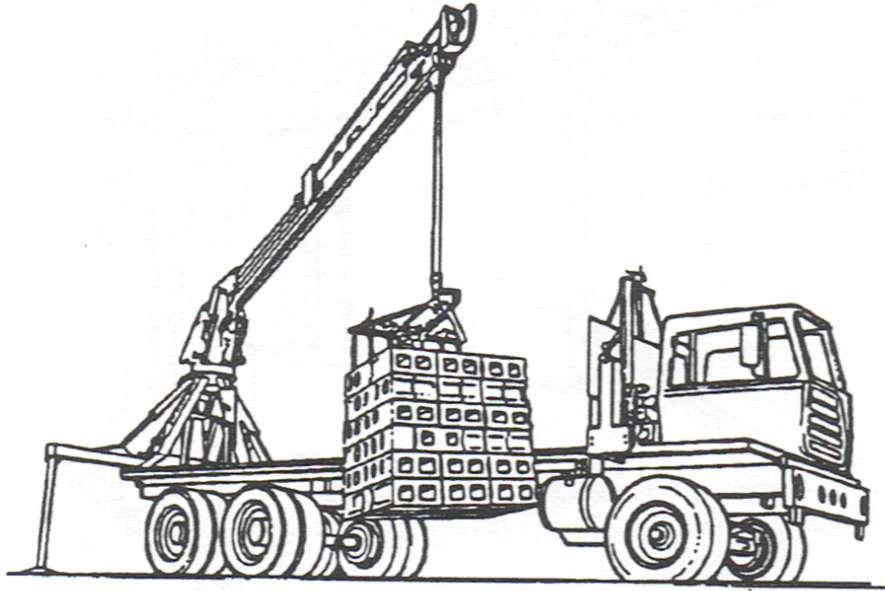

Fixed boom

Illustration 7 Bridge cranes

Overhead-Track Mounted Cranes

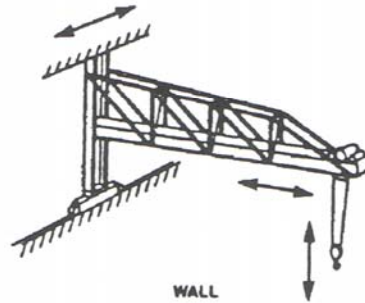
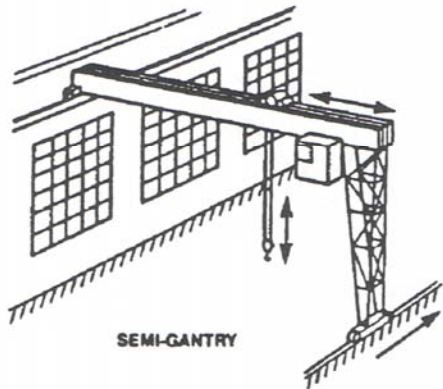
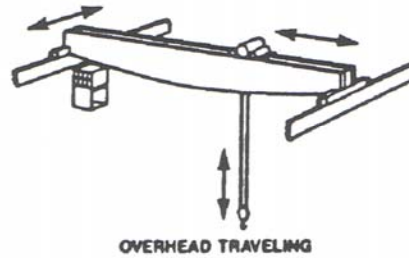
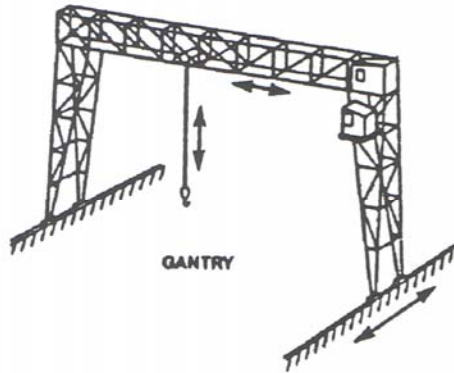

ANSI B30.2-1967
Authorized by ASME

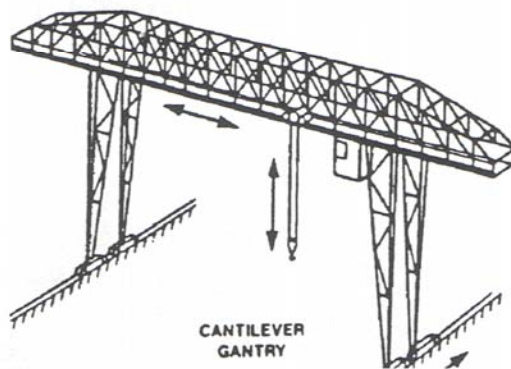

ANSI B30.2-1967

Illustration 8 Tower cranes

Track-Mounted Fixed-Boom Cranes

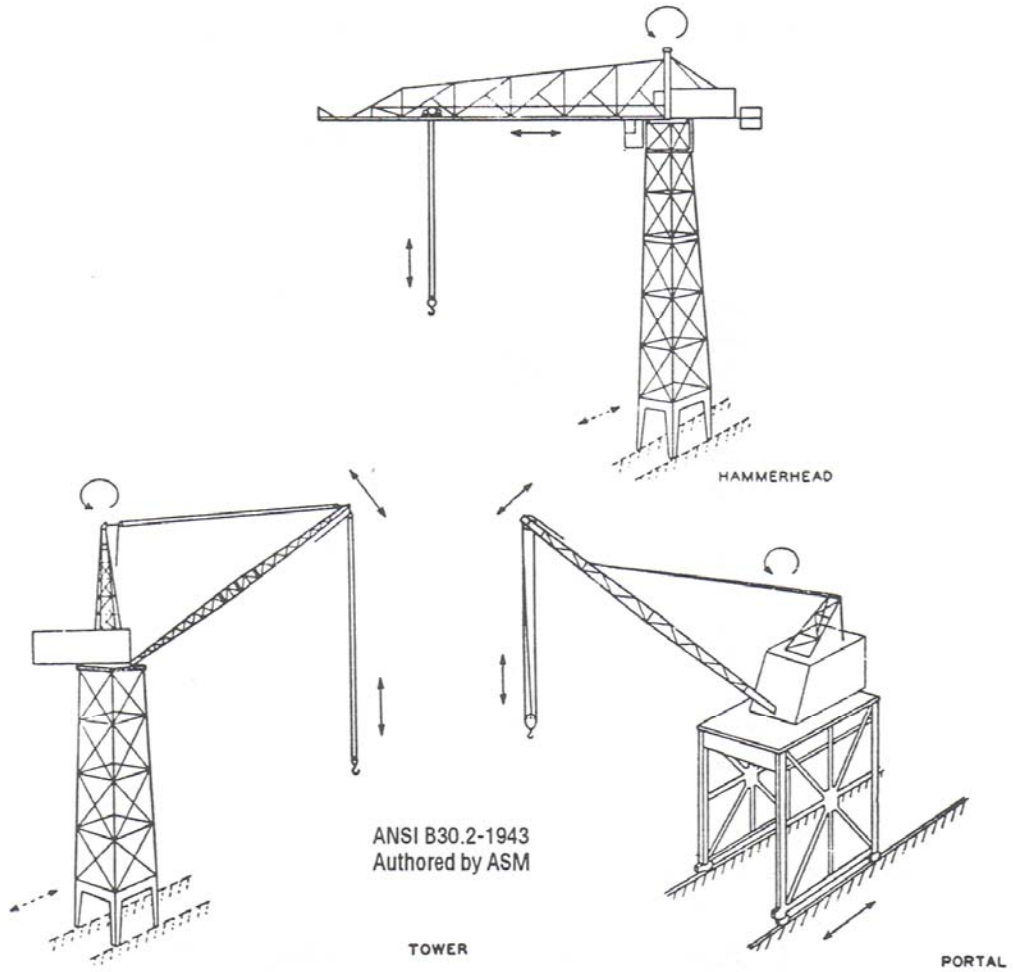

5. Monorails and Underhung Cranes (Hoist)

Illustration 9 Hammerhead Cranes

Hammerhead Tower Cranes

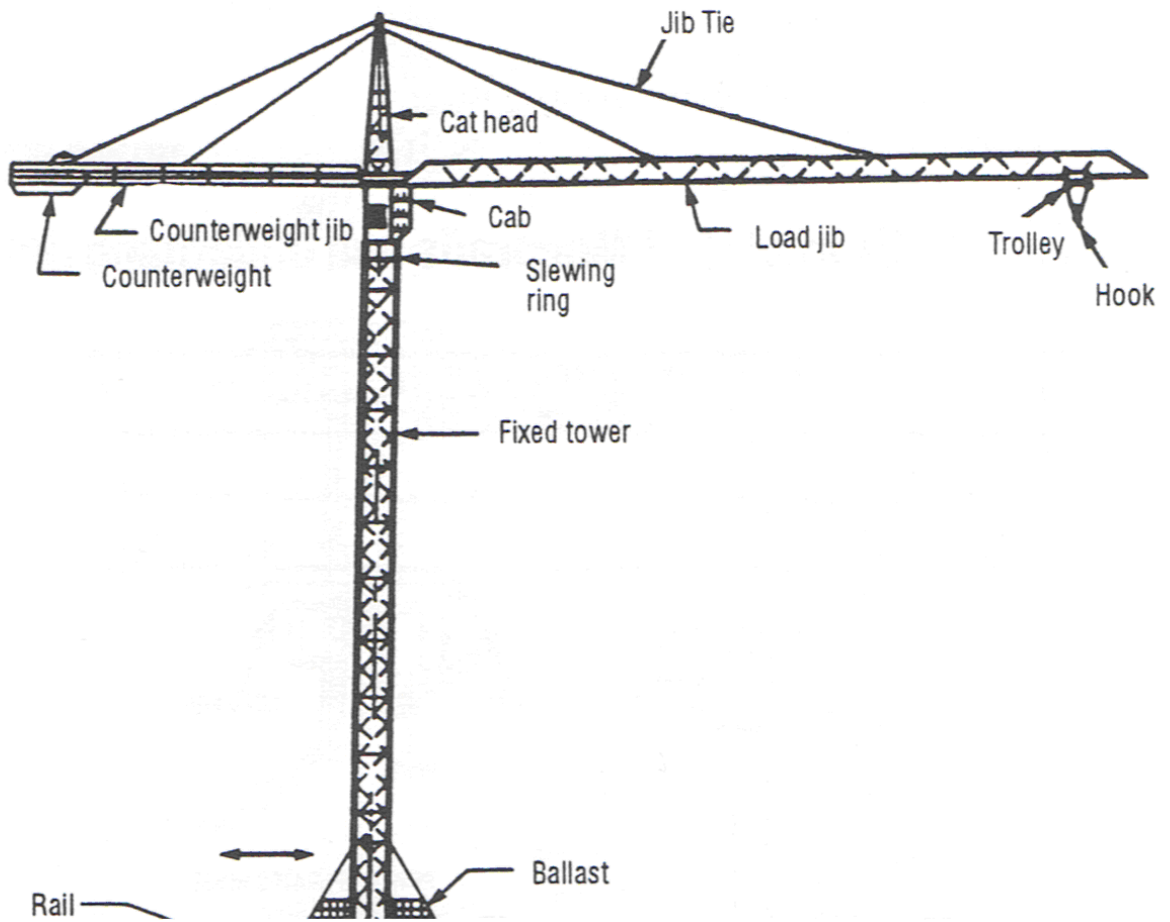

Wheel-Mounted Straddle Lift

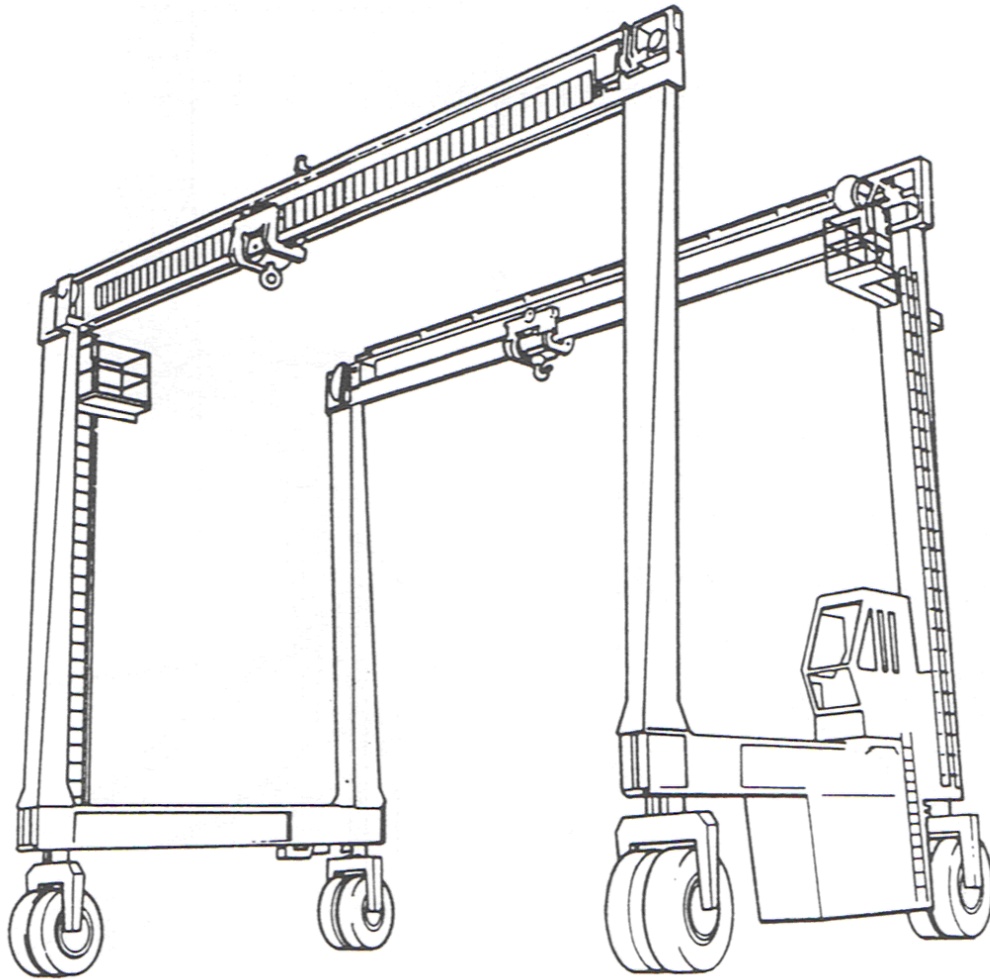

Aerial Lifts

Aerial lifts are of many types:

- ◆ Truck-mounted rotating
 - Articulating and telescoping boom
 - Articulating boom
 - Telescoping boom (Illustration 14)

- ◆ Self propelled
 - Articulating and telescoping boom (Illustration 11)
 - Articulating boom (Illustration 12)
 - Self propelled scissor lifts (Illustration 13)

Illustration 11 Self Propelled Aerial Lift: Telescoping Boom

Self Propelled Articulate Telescoping Boom

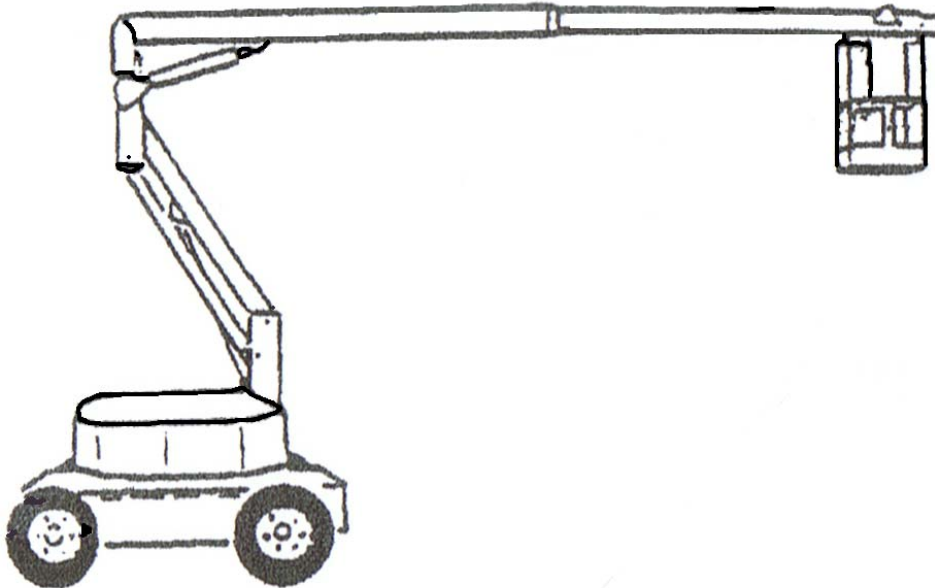

Illustration 12 Articulate Self-Propelled Outrigger

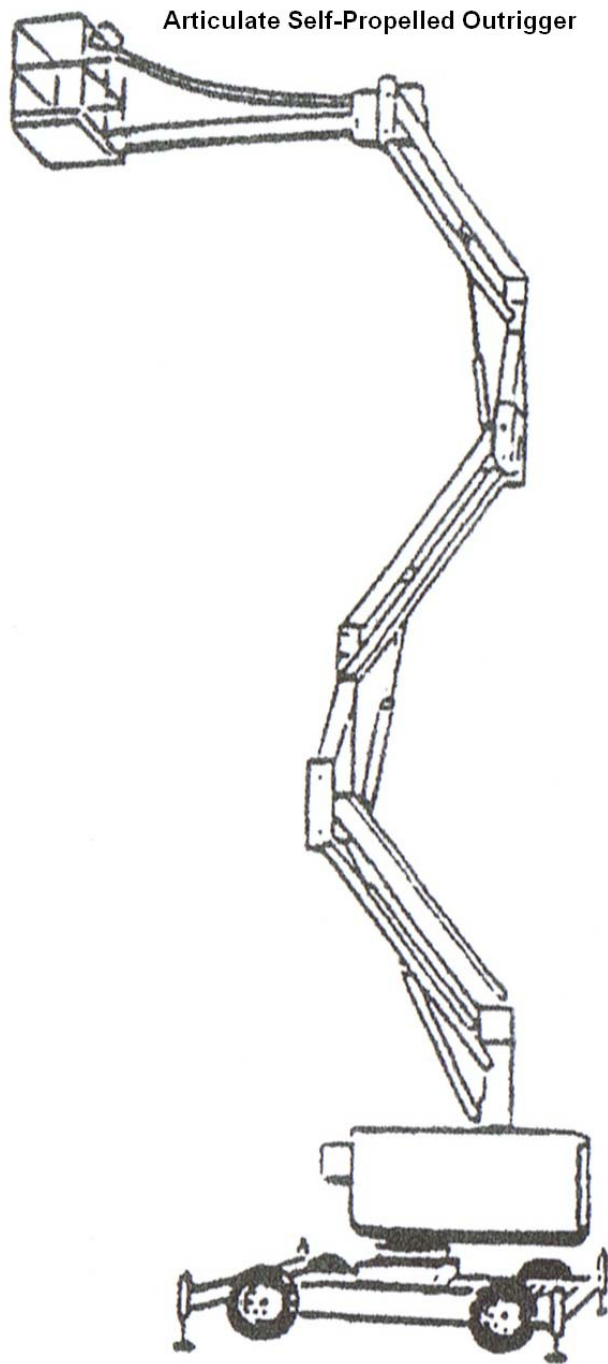

Illustration 13 Scissor Lift

Scissor Lift

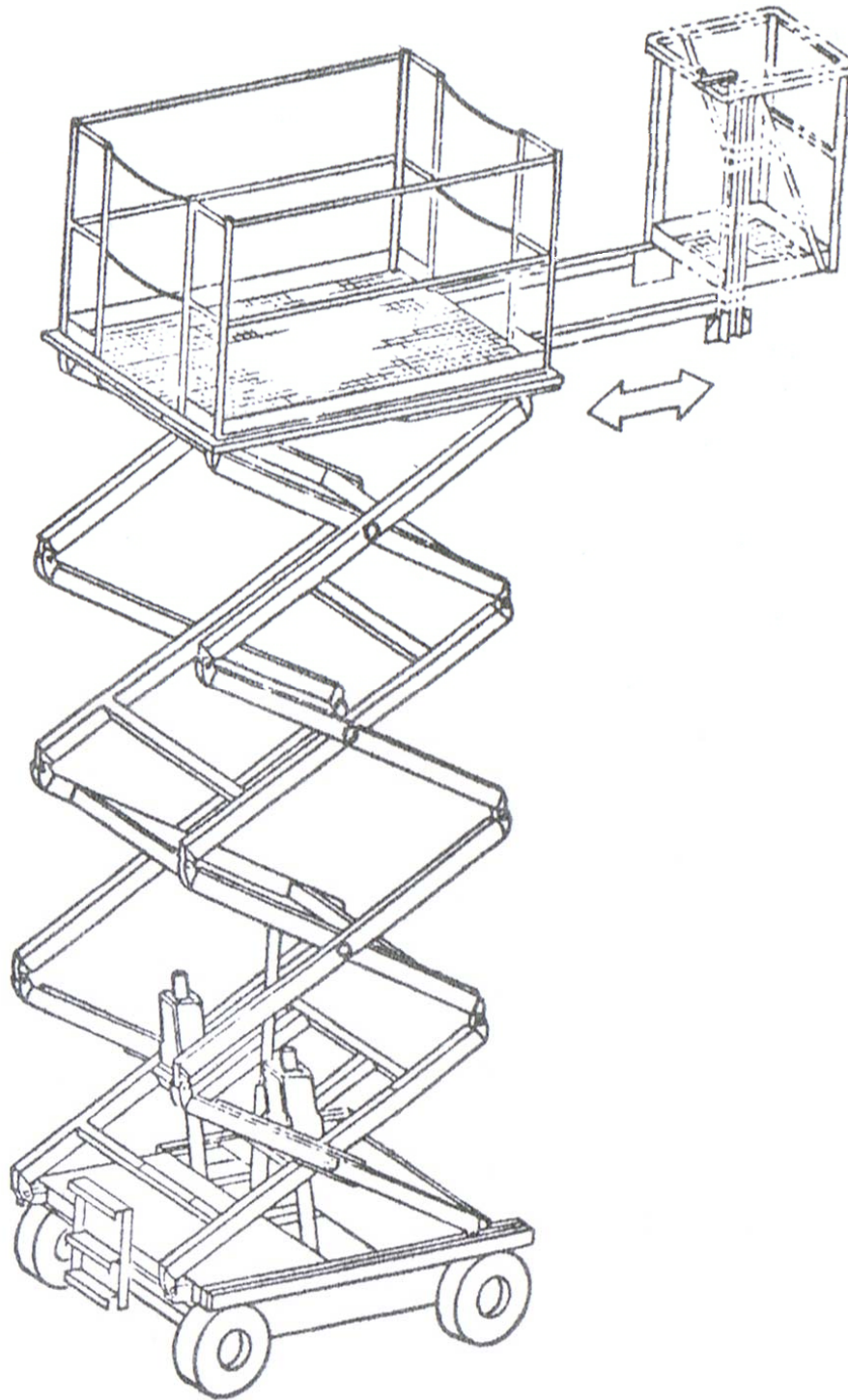
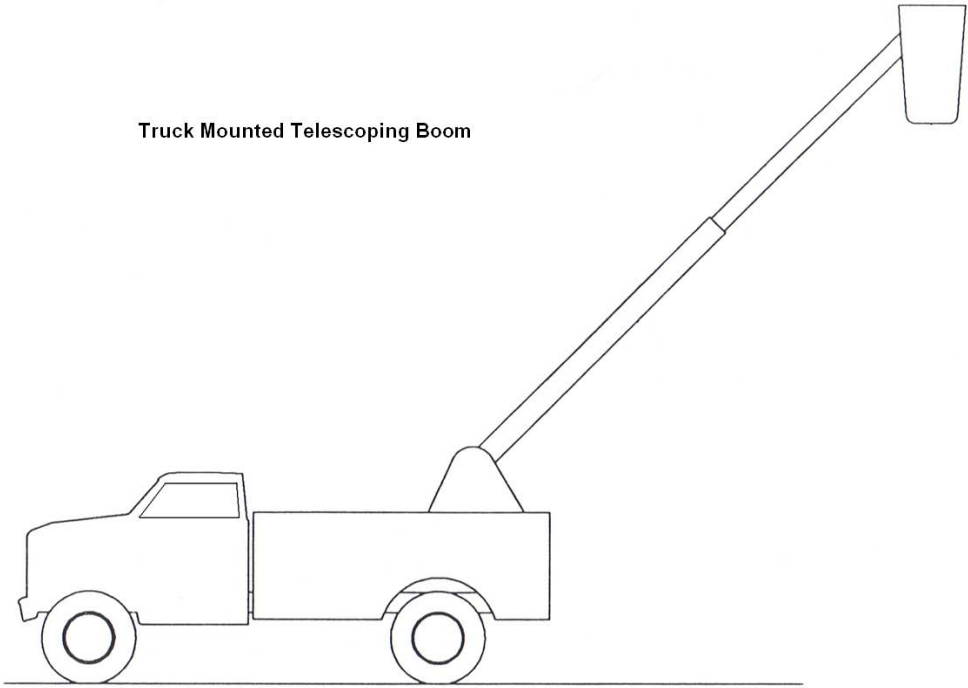

Illustration 14 Truck Mounted Telescoping Boom (also may be self-propelled)





Five Prominent Hazards

The hazards commonly encountered by both cranes and aerial lift operators and users are deadly, yet preventable by design while priced cost-effectively. Five prominent hazards are common to both cranes and aerial lifts:

- ◆ Powerline contact
- ◆ Overload
- ◆ Error provocative operator controls
- ◆ Blind zones
- ◆ Inadequate access

Illustration 15, a chart, which illustrates the hazard, failure mode, consequence and the appropriate engineering control for these five common hazards, presents a basis for examination in greater detail.

Illustration 15 Hazard Chart

Hazard	Failure Mode	Consequence	Engineering Control
---------------	---------------------	--------------------	----------------------------

<p>Powerline Contact</p>	<p>Boom strikes powerline</p> <p>Hoist line strikes powerline</p> <p>Conductive material touching crane or aerial lift strikes powerline</p> <p>Aerial lift operator strikes powerline</p>	<p>Ground Fault</p> <p>Electrocution</p> <p>Damage</p>	<p>Relocate or bury powerlines prior to operation of equipment</p> <p>Range limiting device</p> <p>Insulating and non-conductive guarding</p> <p>Insulated link</p> <p>Proximity alarm</p> <p>Identify the powerline danger zone on the ground with conspicuous markers</p>
<p>Overload</p>	<p>Load exceeds tipping or design limit or a load that is not freely suspended</p>	<p>Upset</p> <p>Structural Failure</p> <p>Injury</p>	<p>Load Moment Indicator</p> <p>Design of object being lifted can be freely suspended</p>
<p>Error Provocative Operator Controls</p>	<p>Unintentional movement of boom</p> <p>Unintentional movement of vehicle</p> <p>Misactivation</p>	<p>Injury</p> <p>Load loss</p> <p>Powerline contact</p> <p>Overload</p> <p>Damage</p>	<p>Control guarding</p> <p>Failsafe control design</p> <p>Emergency stop</p> <p>Controls that do not return to “neutral”</p> <p>User information system</p>
<p>Blind Zones</p>	<p>Vehicle/equipment strikes bystander/worker</p>	<p>Upset</p> <p>Injury</p>	<p>Smart reverse signal alarm (only sounds when</p>

	<p>Vehicle/equipment strikes property</p> <p>Vehicle/equipment veers off path and upsets</p>	<p>Property/equipment damage</p>	<p>object is in the active blind zone)</p> <p>Closed-circuit TV</p> <p>UHF near-object detection with automatic stop</p> <p>Travel alarm</p> <p>Aerial basket cage (See Illustration #18)</p>
<p><i>Inadequate Access</i></p>	<p>Fall from elevation</p> <p>Fall same level</p> <p>Fatiguing</p>	<p>Injury</p> <p>Awkward and stressful</p>	<p>Appropriate handrails for walkways and stairways</p> <p>Safe 3 point vertical accessway*</p> <p>Access ladder and handrails to top of crane cab to access the A-Frame</p> <p>Handrails on walkway to aerial basket and gate on aerial basket</p> <p>Alternate walkway to tower crane</p> <p>Elevator to tower crane</p>

* One hand and two feet or two hands and one foot contacting at all times

Common and individual hazards applicable to cranes and aerial lifts will be referenced in Appendix A: Litigated Cases, with an example of a typical failure mode that has been subject to litigation. Hazards are separated in numerical sections.



Section 1: Powerline Contact

Unintentional contact with powerlines by cranes and aerial lifts continues to be a principal source of catastrophic events, including serious and painful injuries or gruesome death. The major powerline contact hazard is armed by the use of metal booms of cranes and aerial lifts that can be raised into powerlines. The height of the booms creates the hazard of boom contact as well as the hazard of hoist line contact with a powerline.

The Occupational Safety and Health Act (OSHA) requires a minimum 10-foot (10') clearance from powerlines. Unfortunately, this requirement has proven to be unreliable, as it is constantly, unintentionally violated by human error and visual misperception. Mistakes made by this inaccurate worker practice cannot be stopped or corrected due to the fact that thin air provides no barrier at the minimum distance from a powerline. Compliance with this requirement relies solely upon the accuracy of human perception, which is not possible to achieve, rendering enforcement of the 10-foot OSHA regulation impossible. Reliance upon human performance of **visually** maintaining a *thin air* clearance of crane boom, hoist line, other parts of a crane, and aerial lifts from powerlines has been an exercise in futility. (See Appendix A [Section 1\(a\)](#): Crane powerline contacts and [Section 1\(b\)](#): Aerial lift powerline contacts for a list of cases.)

Review of 1,500* occurrences from the period of 1950 to 2006 indicates that *thin air* clearance standards to avoid powerlines needs to be rewritten to include the use of safety appliances. The Hazard Information Foundation, Inc. (HIFI) authored a research report on history and prevention of powerline contacts* that explains in detail the causes of this serious hazard syndrome. Examination of the 1,500 crane powerline-contact litigation records reveals a key factor: The contact in the overwhelming majority of cases was made mid-span on the powerline between the supporting powerpoles or towers. My personal visits and reviews of many accident sites to determine the cause found that the injured workers were the victims of unforgiving circumstances that include a lack of visual cues to alert them to the presence of a powerline.

Circumstances of contact occurrences consistently included an absence of warning to the presence of an overhead powerline, no mechanical aid restricting the operating scope of the boom to within a safe envelope, and no guarding with insulation. The use of redundant safeguards would significantly overcome the unreliable human performance to prevent equipment powerline contact. The steps needed to control this devastating hazard can be achieved with a change from the 10-foot thin air clearance mandated by current government regulation to management incentives to implement the following measures:

* Research report: "Safety Interventions to Control Hazards Related to Powerline Contact by Mobile Cranes and Other Boomed Equipment" distributed in 2004 by the Hazard Information Foundation, Inc (HIFI), Funded by the Center to Protect Workers' Rights (CPWR).

1. Require construction plans and specifications to remove, relocate, bury, or de-energize powerlines *before* the crane or aerial lift appears at the work site.
2. Establish a worksite procedure to always barricade, flag, or mark the Danger Zone *on the ground*, where it is easily seen and shall not be violated (see Illustration 16). OSHA should include a requirement for a standard written procedure to first map the 10-foot powerline danger zone on the ground as shown in Illustration 16. This practice will provide guidance on how to stay out of the danger zone created by powerlines to both the crane operator and the rigging crew.

Illustration 16: Danger Zone



Map and Barricade the 30 foot wide Danger Zone (15 feet on each side of the powerline poles).

3. Develop a process to install accessories such as the proximity alarm, which warns of the presence of powerlines, on all cranes. Recently developed wireless proximity alarms can be planted in various locations on boomed equipment, and provide more effective protection than a single antenna³. Other safeguards include an insulated link (to prevent the flow of electric current) and a range-limiting device (to keep boom movement within a defined parameter). Elimination of powerline contact hazards requires utilization of redundant engineering controls (multiple safety appliances). Redundant safety features that will provide effective controls are the only way to ensure for reasonable back-up safeguards in the variety of work-site situations faced by construction workers. The proximity alarm identifies the presence of powerlines; the range limiting device restricts boom movement to a safe, predetermined envelope zone. The insulated link provides a ground fault protection to the workers guarding the load. The concept of redundancy starts with the use of a proximity alarm to alert the crane operator and crew that they are working close to a powerline.
4. OSHA requirements should provide workers and employers with options to control the hazards via the *tools* of safety appliances, and encourage the creation of standard procedures that are reasonable safe-work methods by worksite personnel. Safety should become a process where

³ Irvin Nickerson of Las Vegas, Nev., has developed and patented a wireless proximity alarm sensor that can be placed on various locations on the crane boom. This new method is even more effective than the conventional wire antenna.

management provides the tools and employees follow safe work processes specific to their circumstances.

5. Cranes fitted with aerial baskets attached to a conductive metal boom or such booms on aerial lifts shall not be used near powerlines. For activities conducted near a powerline, a non-conductive basket with a non-conductive insulating cage fitted to the basket should be designed to provide an effective guard against unintentional contact with an energized powerline by the person in the basket. This cage will provide a reasonable degree of protection to those who service cable TV and telephone systems⁴, engage in tree trimming near energized powerlines, install traffic signals, or similar tasks. However, this equipment will not serve as a safety feature to allow untrained personnel to work within the OSHA requirement that delineates a ten-foot clearance from powerlines. See Illustration 17.

⁴ According to the National Electric Safety Code ANSI C2, Table 231-1 allows clearance below an energized bare conductor as little as 24 inches.

Illustration 17: Boom Cage

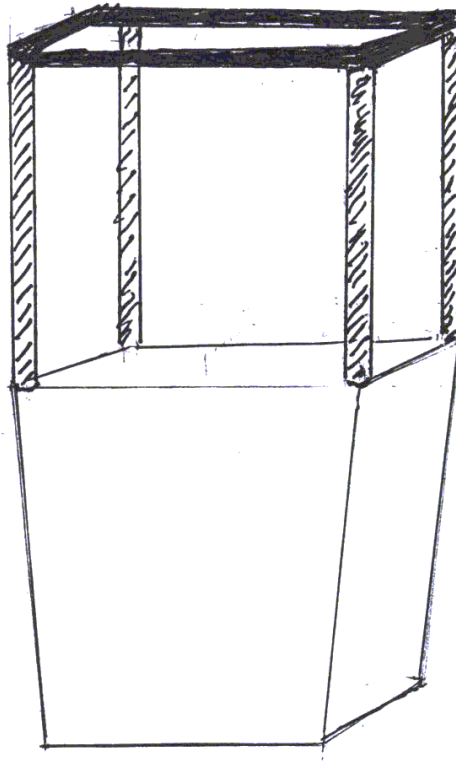

Conceptual design of a non-conductive framework boom (above): The non-conductive basket prevents the occupant in the basket from inadvertent contact with bare live powerlines. This device provides a backup for workmen using a non-insulated aerial lift.

6. Alternate or remote controls for cranes and emergency controls for aerial lifts shall incorporate design features that prevent a ground fault through a user who is standing on the ground.

7. Operating personnel shall be trained in the above six requirements and procedures necessary to prevent crane or aerial lift powerline contacts. A certificate of this training shall be included as a condition of operation and/or use of a crane or aerial lift. A record of the contents of this training shall be maintained to ensure that the safeguards listed above are provided and these safety procedures are being followed.

Each type of aerial lift has unique hazards of its own. A brief history of these devices provides an insight as to why they were designed with inherent hazards. Aerial lifts were first developed to service the warheads of early air missiles. These lifts needed to have a non-conductive boom to prevent the flow of static electricity. These first lifts were of a simple design that consisted of a tubular fiber glass boom with a plastic basket. The controls were in the plastic basket so the operator who was in the basket could control the boom of the lift. The boom was mounted on a small turntable on a pedestal placed upon a lightweight truck bed. This concept was quickly adopted by the electric utilities for powerline installation and live line hot work. Early models included a two-section articulate boom with an uninsulated lower section. Also, some had uninsulated, short metal jib booms used to lift transformers, and others had metal joy stick controls that created a fault circuit for the operator if a phase-to-phase powerline contact occurred when the jib stuck a phase conductor. Since that time, insulation on both lower and upper sections of the boom, as well as other design features of lifts used in the electric utility industry, has been greatly improved to

provide protection to utility linemen. (This type of work also requires a number of additional safety appliances and personal protective devices, including insulated line covers, rubber gloves, rubber sleeves, and non-conductive hard hats.)

Aerial lifts used for tree trimming, installation of traffic signals, replacement of highway lights, telephone and cable TV installation, and other tasks that bring workers in close proximity to powerlines are susceptible to this hazard. The American National Standards Institute (ANSI) National Electric Safety Code (NESC) (C2) Table 325-5 allows for a clearance of only 40 inches below uninsulated powerlines of voltages up to 8.7 kilovolts. Uninsulated aerial lifts are banned from use next to powerlines. For a number of reasons this prohibition is often violated. Qualified electric utility linemen who work close to powerlines are often victims of unintentional phase-to-phase powerline contact, despite their use of insulated baskets. Use of non-conductive cages discussed and illustrated (see Illustration 17) in this document is a necessary prevention method of powerline contact injury.

Aerial lifts and the hazard of powerline contact have two areas of concern. First: Aerial lifts used by the electric utility industry have their own set of rules when working within the 10-foot danger zone next to powerlines. Their aerial lifts must comply with ANSI.SIA A92.2 (Vehicle-Mounted elevating and rotating aerial devices 2001 and OSHA requirements 1910.137 and 1926.950-960 subpart V: Power Transmission and Distribution). Second, uninsulated aerial lifts used for other tasks are often situated immediately adjacent to powerlines (see OSHA 1926.550(a)(15)(i/iii) Clearance from powerlines). Decreased clearance should

not occur unless an insulated lift is used by a journey lineman in compliance with ANSI A92.2. The majority of injuries from powerline contacts occur when the aerial lift does not have an insulated boom and basket, or the work site did not have the benefit of pre-job planning to de-energize or remove powerlines.



Section 2: Overload

Overloads resulting in upset, and in some instances include structural failure, are a hazard common to both cranes and aerial lifts. Nearly all of these failures can be prevented with a Load Moment Indicator (LMI), a device that provides warning of overload to the operator. LMIs also intercede to prevent further movement of the boom, preventing the lift of loads that exceed the rated capacity of the crane or aerial lift. All cranes and aerial lifts without this appliance are inherently dangerous. (See Appendix A [Section 2\(a\)](#): Crane Upset for a listing of prominent crane overload litigation, and [Section 2\(b\)](#): Aerial Lift Upset litigation.)

Hydraulic telescoping or articulate boom cranes are most often confronted with the hazard of upset or boom collapse from overloading. Cranes can be vulnerable to upset with either extended or retracted outriggers. A reduction in these occurrences has been achieved with the use of Load Moment Indicators (LMIs). The newest types of LMIs for hydraulic telescoping boom cranes have software programs that provide a rated capacity for all boom positions with both outriggers extended and in place or retracted.

From review of over 1,000 crane upsets occurring over a thirty-year period, it can be projected that an upset occurs once in about every 10,000 hours of crane use. Nearly 75% of these upsets were the result of error-provocative circumstances that caused the operator to inadvertently exceed the crane's lifting

capacity. The good news is that in the decade of 1993-2003, the occurrence of crane upset from overloading in the categories of outrigger retracted and extended started to decline. This trend can be attributed to the industry acceptance and use of load moment indicators (LMIs). New technology of wireless LMIs make it easier for them to be installed on both telescoping and latticework boom cranes. Wireless systems are exceedingly helpful in providing utility for converted tower cranes. However, when averages of failures are examined, they remain constant. Even with fewer upsets occurring, the failure modes remain the same, as the older cranes are not equipped with LMIs. The following breakdowns were made:

- 15%** were in the travel mode
- 39%** were making swings with outriggers retracted
- 15%** were making a pick with outriggers retracted
- 14%** were making a pick or swing with outriggers extended
- 6%** were making a pick or swing, use of outriggers unknown
- 7%** were due to outrigger failure
- 4%** were from other activity
- 3%** resulted in fatalities
- 8%** resulted in lost-time injuries
- 20%** resulted in significant damage to property other than the crane

Licensing programs of crane operators should include certification of the use of LMI systems to help alleviate incidents caused by incorrect use. When aircraft pilots became licensed in the use of electronic navigation systems, this knowledge reduced the occurrence of craft becoming lost in fog or darkness. Crane operators licensed in the use of the LMI will reduce the occurrence of upset. In many instances of upset of a crane equipped with an LMI, the crane operator did not utilize the LMI by turning it off, or was unfamiliar with its proper

use. It is crucial that the operator is familiar with the basics of LMI use, because the LMI needs the correct measurements as input in order to calculate safe angles and degrees of lifting capacity. Many cranes upset because operators enter incorrect information. Construction managers should have at least rudimentary knowledge of LMIs in order to be able to double-check a crane operator's measurements. If no one on the site has adequate knowledge in LMI requirements, the blind lead the blind, and a safe lift is not guaranteed. A licensing program of crane operators that includes certification as competent in the use of the LMI provides a higher degree of authority to accept a safe lift and reject an unsafe lift. All crane operators should be certified by the manufacturer of the LMI of which the crane is equipped. Such credentials warrant a higher pay scale. This compensation is a bargain when compared to the high cost of crane upset by an unqualified operator or incompetent supervision which overrules a certified operator.

There have been documented cases of outrigger failures from structural defects. The hazard of inadequate soil support remains a continuing peril. Soil conditions range from wet sand that can support only 2,000 lbs/square foot to dry clay that can support 4,000 lbs/square foot to well-cemented hard pan that can support as much as 10,000 lbs/square foot⁵. Outriggers sinking into the soil even as little as half an inch can reduce the lifting capacity of a long boom. For this reason the crane needs to be set on mats or outrigger pads whenever soil conditions are questionable. The footings for a tower crane always need to be

⁵Pg. 38, *Crane Hazards and their Prevention*, MacCollum.

calculated by a licensed engineer proficient in soil mechanics who will stamp and seal the design to ensure that the footing is strong enough and absolutely level.

Proactive construction contract specifications should include a clause stating that tower cranes should be inspected by a third-party certifier before and after set-ups every time they have been used. The erection of both mobile and fixed-base tower cranes need to be supervised by a person qualified by the crane manufacturer. In addition, *all* cranes should be inspected annually by a nationally recognized crane inspection service.

Only freely suspended loads should be lifted. Freeing a form panel stuck to freshly cured concrete, raising piling with a vibratory pile driver, or lifting a floating log of unknown weight all involve loads that are not freely suspended. Sometimes an operator needs to be able to let the load free fall to overcome an unintended overload from loss of stability (such as overload). Additional hazards can result from the use of logging tongs to guide a heavy floating object. In one situation, management provided the crane operator with logging tongs attached to the hoist line to guide a heavy floating log over the spillway of a dam. When the log was caught by the current and could not be released from the tongs, it pulled the crane into the water and the operator drowned.

Flatbed trucks that have hydraulic cranes mounted on them have a very high center of gravity and are known to upset while being driven (roaded) or being parked by the edge of a road where the road shoulder slopes away. It appears that the electronic stability controls that have been so successful in

preventing upset on SUVs would prove to be an effective safety feature on these flatbed mounted cranes.

Aerial Lift Upset

Both truck-mounted and self-propelled aerial lifts have a high center of gravity and upset in the travel mode. This instability can be attributed to an absence of an electrical stability system. Those with outriggers need functioning interlocks to limit boom movement to times when outriggers are extended and in place. Aerial lifts with counterweights must effectively intercede to limit boom movement to within the scope of design for the maximum foreseeable weight of the operator and foreseeable specified weight of tools or materials.

Self-propelled aerial lifts are very prone to upset on sloping and potholed surfaces. Self-propelled scissor lifts can easily overturn if one wheel slips into a hole. Some models have a much lower clearance from the floor, which prevents the scissor lift from falling over.

According to Maura Poternoster, risk manager for Insurance Services for American Rental Association⁶, many aerial lift injuries stem from a failure to inspect and maintain the equipment before it is rented to users. Some 40% of claims involve tipover caused by a failure to inspect. Annual third-party inspections of aerial lifts would reduce failures that may lead to upset.

⁶ From article in *Lift and Access*, April 2007



Section 3: Error Provocative Controls

A third common hazard arises from error-provocative operator controls. Faulty or unguarded controls can cause unintended activation of the boom or cause freefall of the load. (See Appendix A [Section 3\(a\)](#), which lists error-provocative control litigation for cranes, [Section 3\(b\)](#) for aerial lifts.)

Crane controls that allow indirect dropping of the load are a frequent defect on older friction-powering latticework booms in cranes without powerlowering.

Aerial lifts have guardrails around the perimeter of the panel, but the panel remains open for easy operator contact*. Inadequately guarded controls on aerial lifts that are accessible to the *body* of the operator are dangerous. Guarding controls prevents unintentional body contact and unintentional activation. The panel should have a top guard bar, as is illustrated by the series of illustrations below.

* This subject is further addressed in the Research report: “Safety Interventions to Control Hazards Related to Powerline Contact by Mobile Cranes and Other Boomed Equipment” distributed in 2004 by the Hazard Information Foundation, Inc (HIFI), Funded by the Center to Protect Workers’ Rights (CPWR).

Illustration 18: Unguarded aerial lift controls

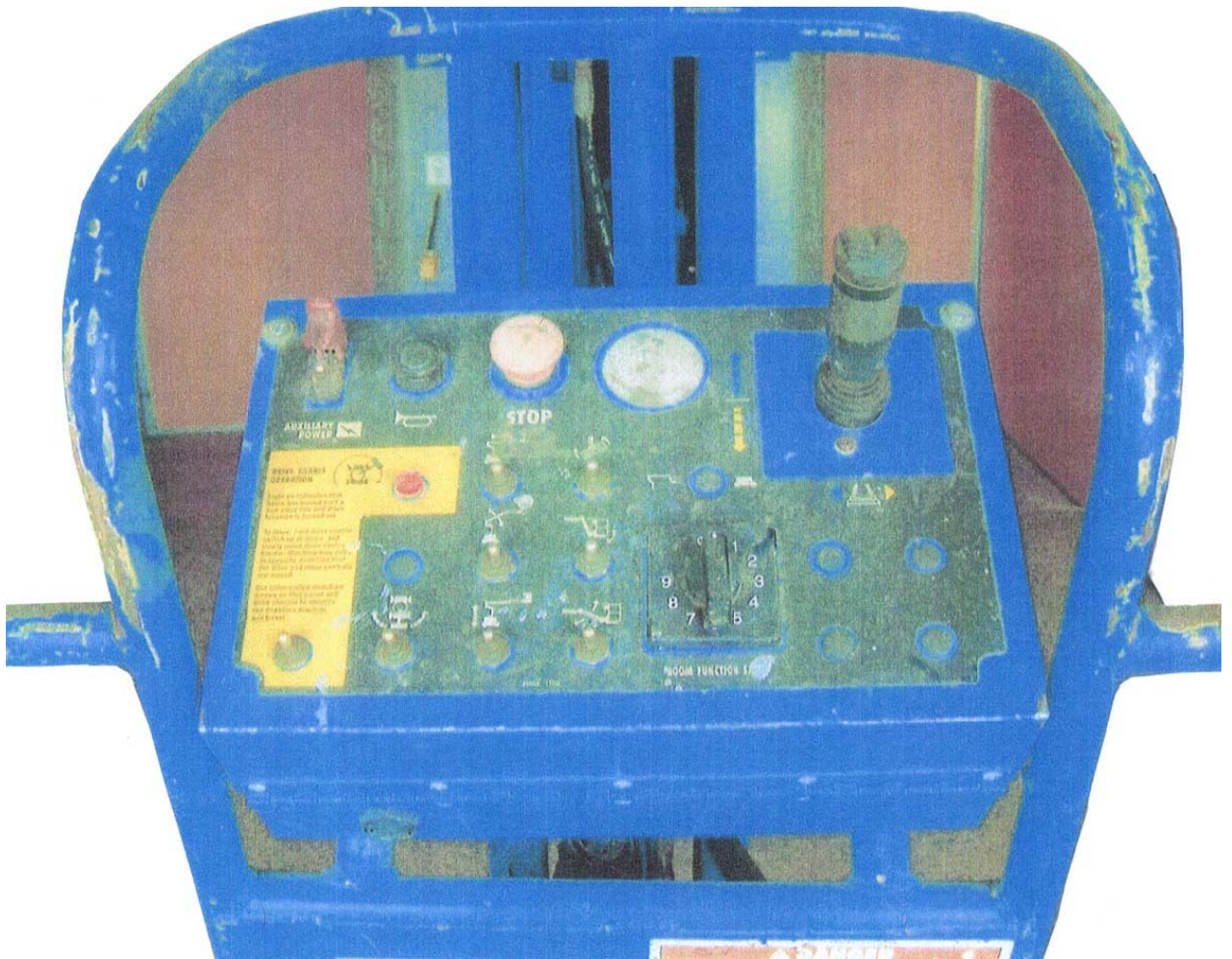

Illustration 19: Guarded aerial lift controls

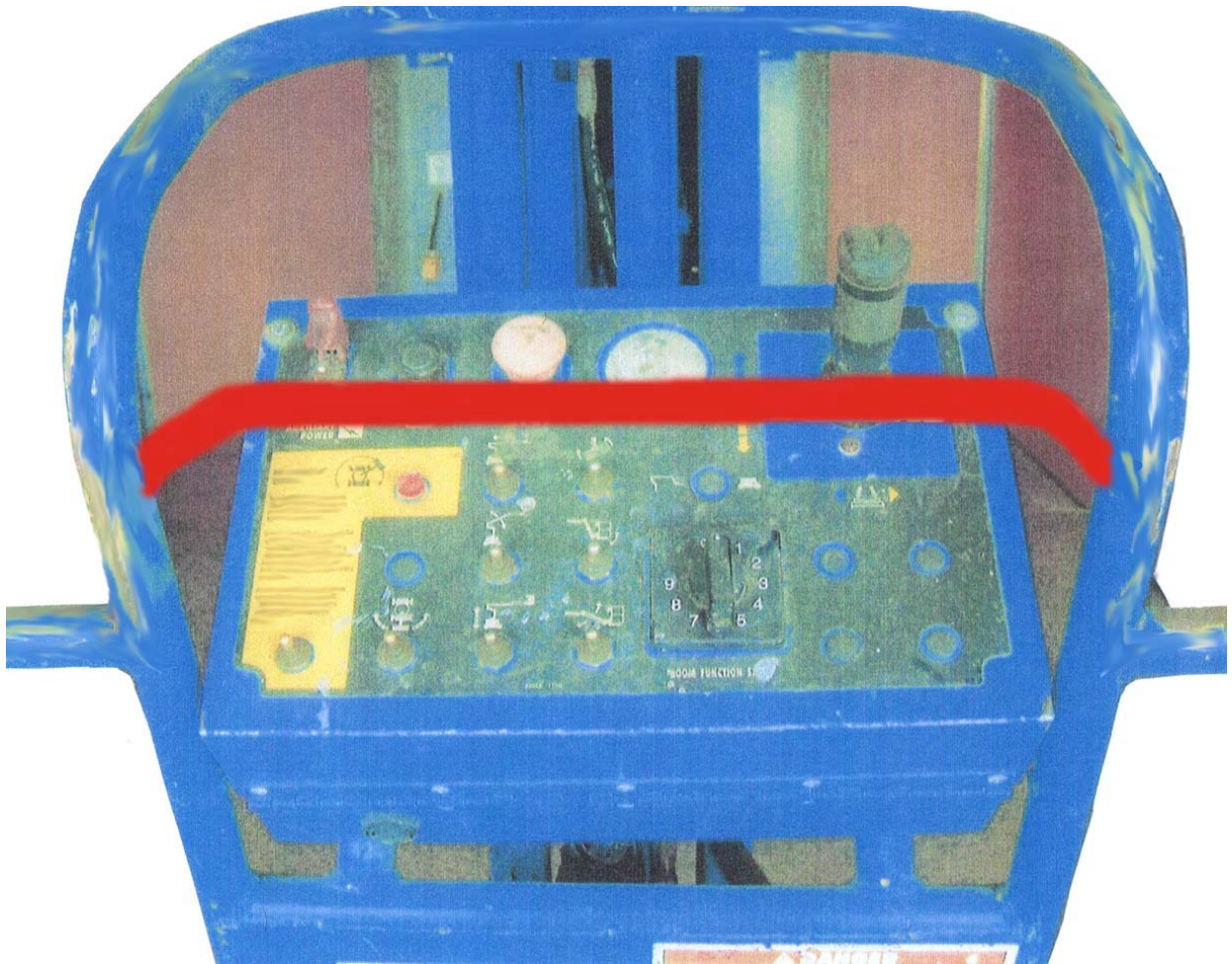

Illustration 20: Guarded aerial lift controls



A number of ANSI standards have required that the control panel “be protected against inadvertent operation” for years. The requirements are listed as follows:

- ANSI 92.2 *Vehicle Mounted Elevating and Rotating Aerial Devices* 1990, 4.3.1: “Aerial devices primarily designed as personnel carriers shall have both upper and lower control devices. Controls shall be plainly identified as to their function and protected from *damage and inadvertent activation* (emphasis added). The boom positioning controls shall return to their neutral position when released by the operator.”

- ANSI A92.5 *Boom Supported Elevating Work Platforms*, 1992 4.10: Controls 410.1- Upper controls (e): “Be protected against inadvertent operation.”
- ANSI A 92.6 *Self Propelled Elevating Work Platforms* 1990, 4, 6 Controls (5): “Be protected against inadvertent operation.”
- State of California Code of Regulations 3462, Elevating Work Platforms Equipment (d): “Any powered elevating work platform shall have both upper control devices. Controls shall be plainly marked as to their function and guarded to *prevent accidental operation* (emphasis added). The upper control device shall be in or beside the platform, within easy reach of the operator. The lower control device shall have the capability to lower the platform where the operator’s safety is in jeopardy.”

The National Safety Council's Study of Aerial Basket Accidents Volume II 1967-71 has 20 examples of injuries from the hazard of inadvertent control activation. This hazard can arise when the operator’s body (chest or waist) can intrude into the control area. Body sizes are well defined in the Society of Automotive Engineers (SAE) J833 Human Dimensions handbook. Also, Woodsen has some data in the *Human Factors Design Handbook* (McGraw-Hill 1981). These same dimensions were listed in the Human Engineering Guide to Equipment Design by the American Institute for Research in Washington, D.C.

Exposed (unguarded) toggle switches have an unsafe design that is currently popular in many aerial lift control systems.

Illustration 21

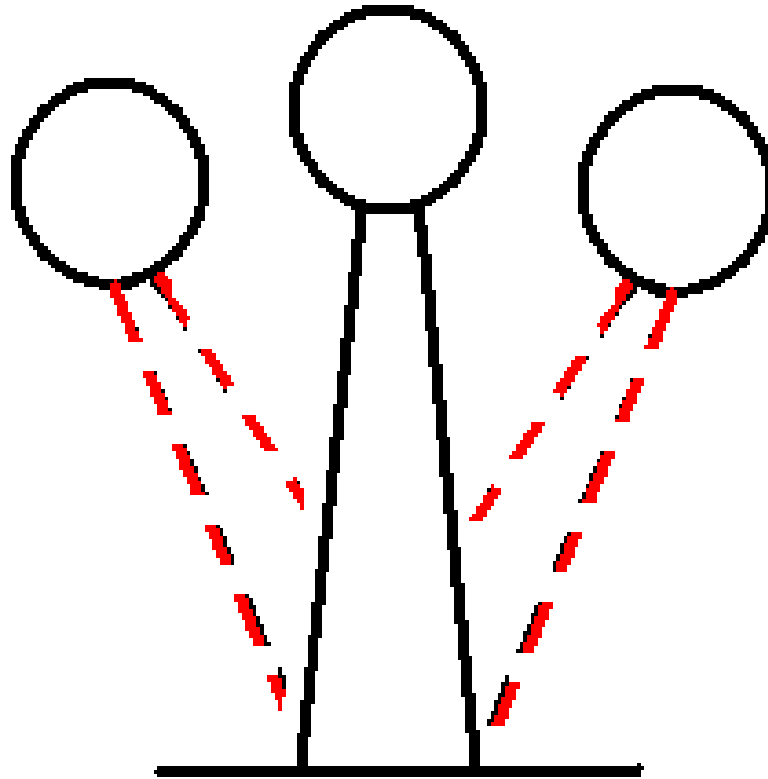

Unguarded Toggle Switch

Illustration 22

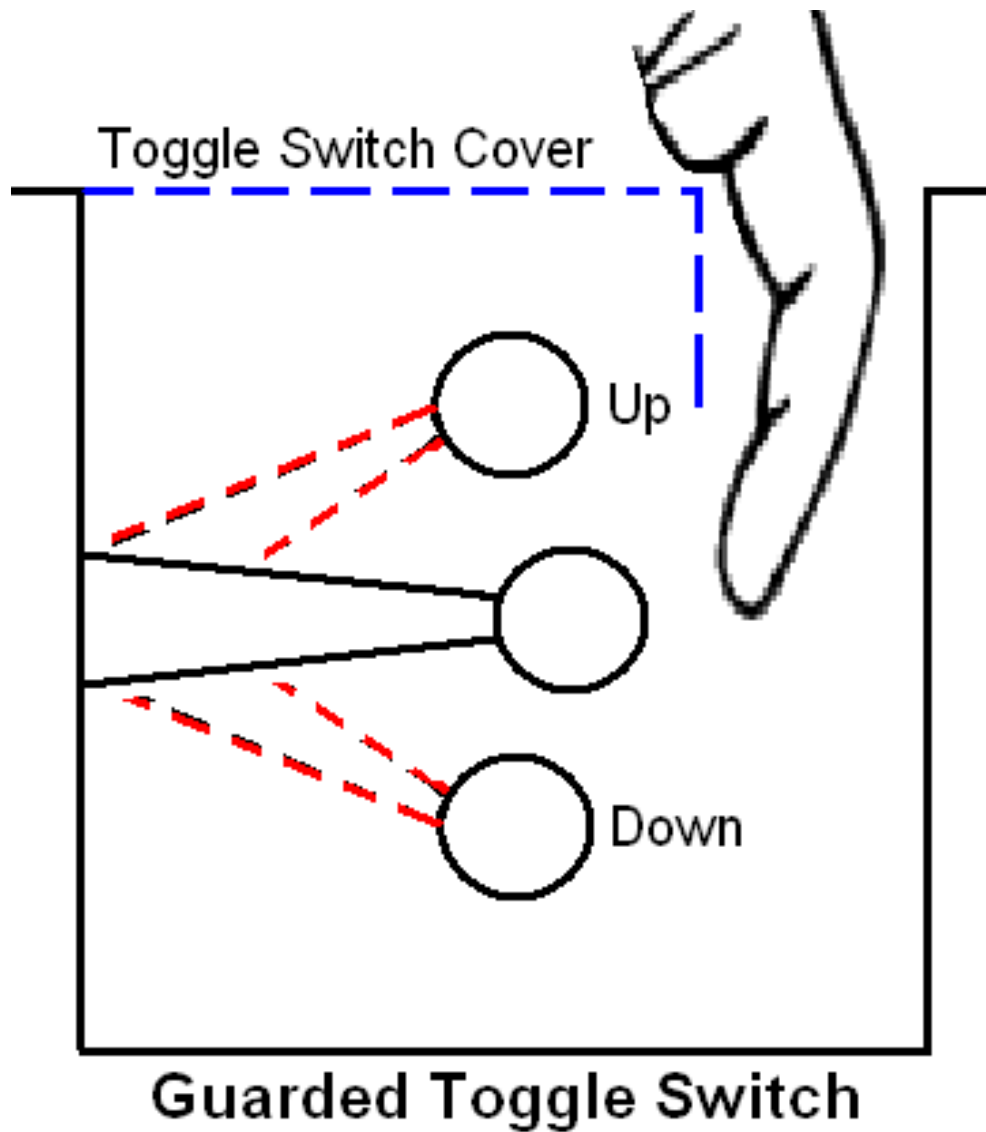

Every control panel should be examined for the hazard of unguarded toggle switches. The conventional toggle switch can be made safer, as done by most Asian and European automakers, by relocating the toggle switch to a vertical position so that downward movement lowers the car window and only upward movement can cause the car window to raise and close. (Exposed rocker

switches in American cars have resulted in a number of child deaths.) The U.S. Department of Transportation (DOT) motor vehicle safety is requiring a design change by 2008 for safer window switches. The same change should be provided for toggle switches in aerial lifts to prevent unintended upward activation errors.

Controls that do not return to neutral when released are the source of inadvertent and unintentional operation. This failure mode is most frequently attributed to two causes:

- ◆ Controls that fail to automatically return to “neutral” are in danger of unintentionally triggering or continuing movement.
- ◆ The return to neutral occurs, but the panel is made from inexpensive and unreliable relays that are vulnerable to sticking, as they weld themselves shut. This malfunction creates a faulty switch response.

Trolley boom cranes have, in the past, had some electrical control system failures of the relay circuit breakers malfunctioning and causing erratic boom operation. Hopefully, most of these cranes are no longer in use, but when one is found to still be in use, the crane control system needs to be checked by a licensed electrical engineer and certified that the relays are of a reliable quality.



Section 4: Blind Zones

Blind zones affect safe operation of both cranes and aerial lifts. On cranes, the crane operator must trust the signal personnel to complete a lift or to move the crane safely. (See Appendix A, Section 4(a), for Blind Zone litigation on cranes.)

Illustrations 23-25 show the areas of vision compromise. Blind zone areas are not uniform, as shown in illustrations. From an outside perspective, it is very difficult to judge the places where the operator's vision may be compromised. Signal personnel should be familiar with the parameters of blind zones on different types of equipment.

**Illustration 23: Manlift from viewpoint of Eye level 10 ft. - 0 in.
above ground level**

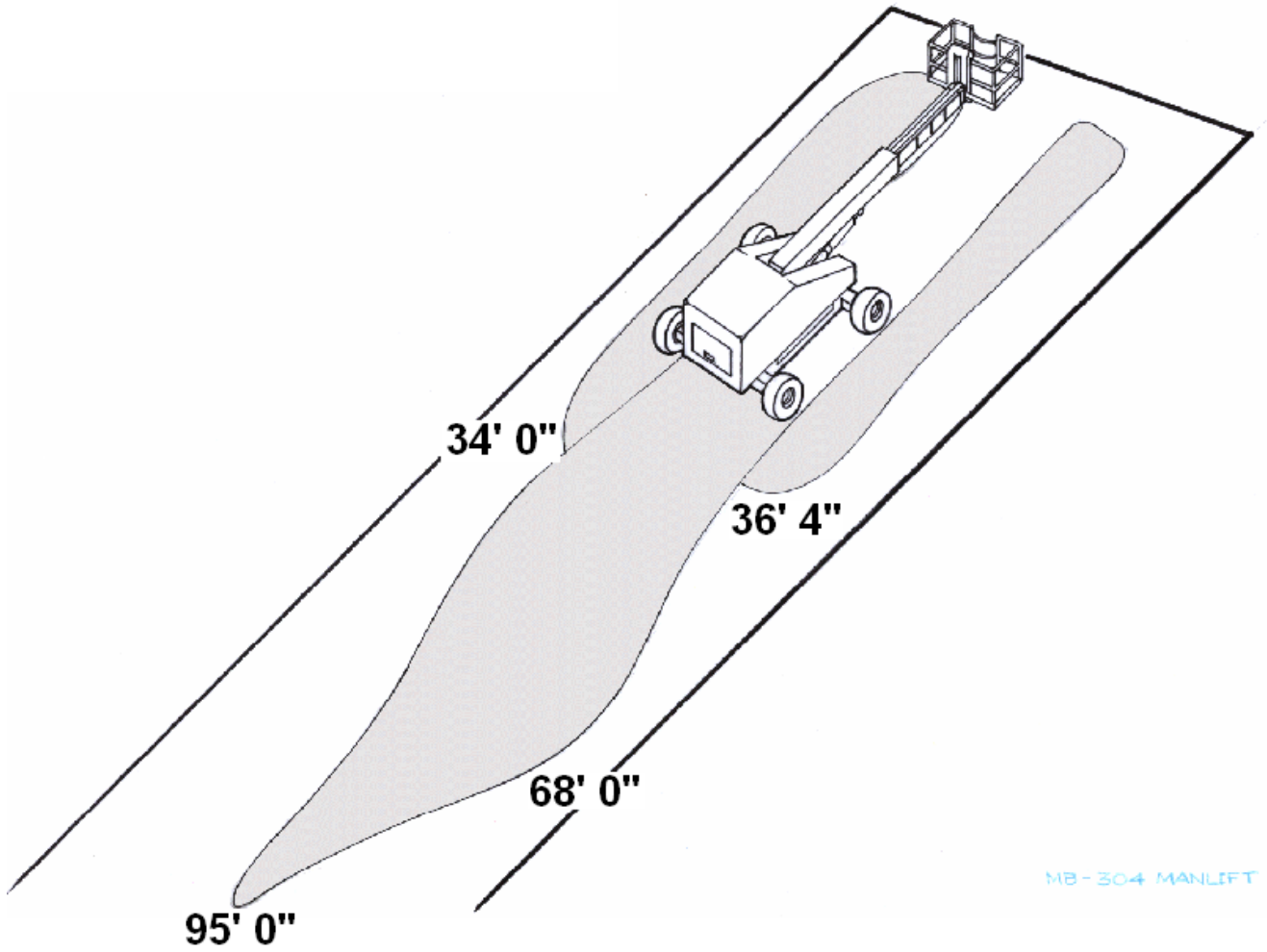

**Illustration 24: Hydraulic crane with viewpoint from Eye level 7 ft. - 0 in.
above ground level**

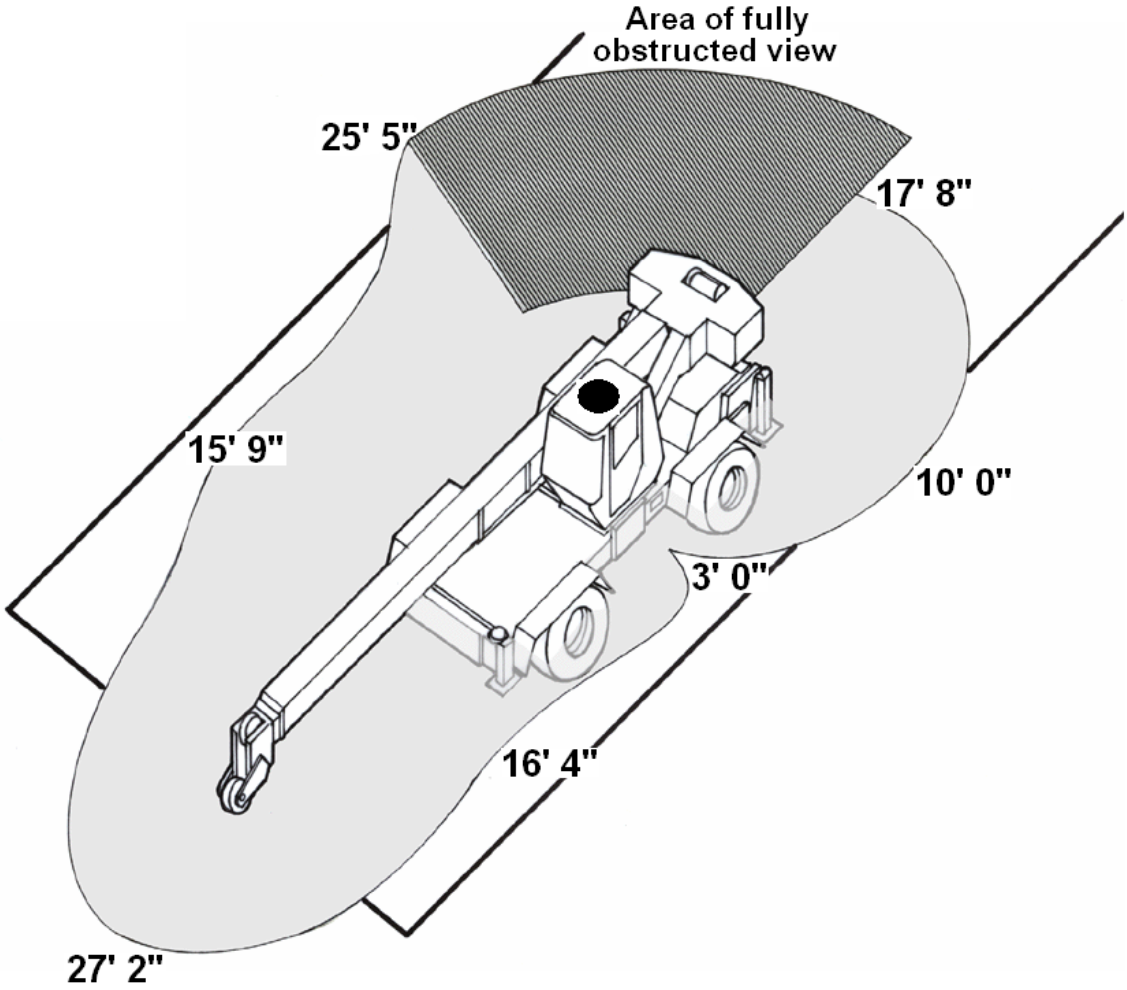

**Illustration 25: Straddle Lift truck from viewpoint of Eye level 14 ft. - 8 in.
above ground level**

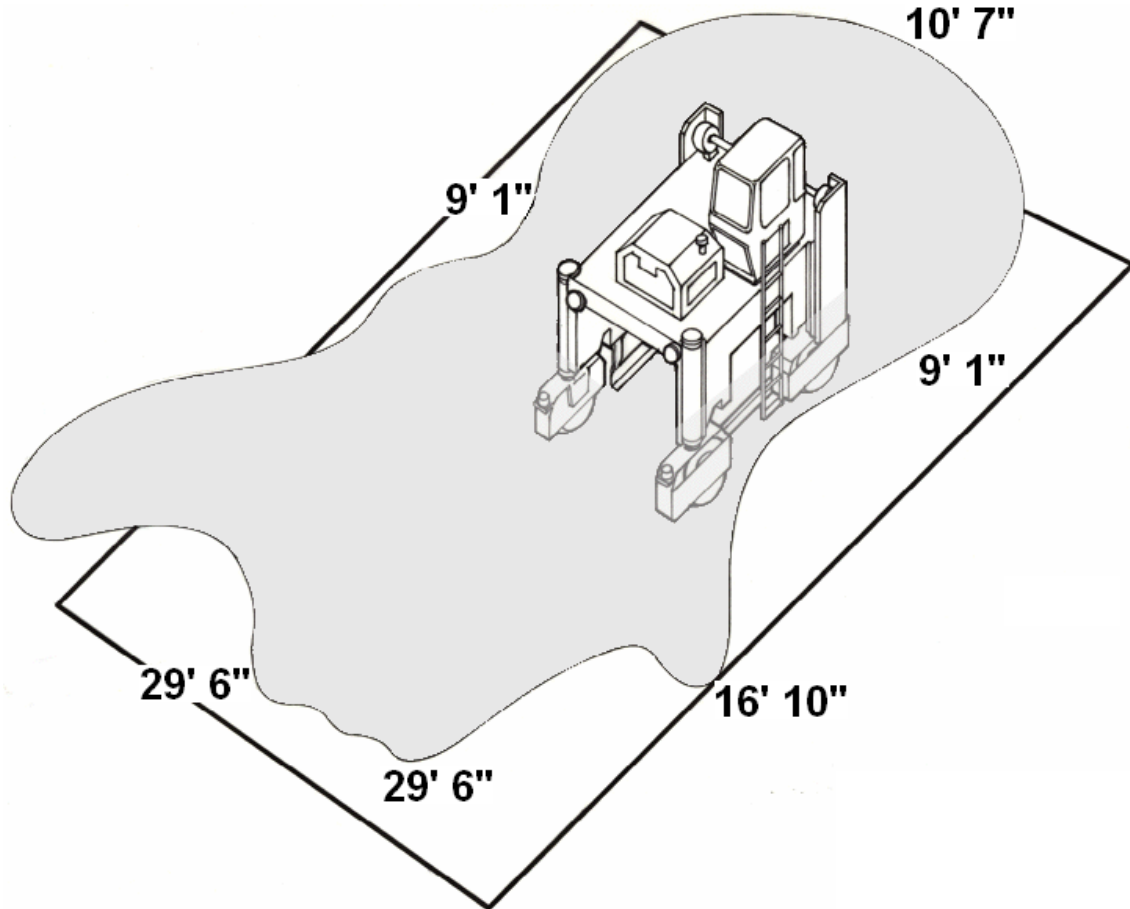

In addition to ground-level blind zones, the operator in the basket is continually vulnerable to objects that may be directly above the operator's head. The presence of overhead trusses, cable trays, and piping or ductwork may create a dangerous overhead blind zone. The assumption that the operator needs only to "look up" is a myth, as people are single-channeled and tend to look downward. The combination of this behavior and an individual's attention being taken by performing a task creates a situation where the individual is

unaware that they are approaching an overhead hazard, which may be behind them.

The December 4, 2006, cover story of *Engineering News Record*, “Out of the Blind Zone,” emphasizes the need for safer radio communication with uniform instructions. A retired crane operator states that guiding an invisible load is the most dangerous crane activity. Good communication is crucial to making a safe list when the operator is unable to see every point in the load’s trajectory. Standardized voice signals in short, two word phrases to crane operators would reduce confusion in lift instruction and improve communication between operator and signaler.

Blind zones on aerial lifts are primarily related to circumstances where the operator must look into the sun in some directions of travel. In these circumstances, the operator cannot see powerlines. This hazard leads back to square one: *powerline contact*, which requires a prohibition of the use of aerial lifts around powerlines except for electric utility operations with insulated systems and other trade requirements. The operator of a self-propelled aerial lift does not generally look overhead. Thus, the space above the crane becomes a blind zone, and the boom can inadvertently be raised into overhead powerlines or, indoors, into a ceiling truss or cable trays. The operator’s cage shown in Illustration 17 provides a way to guard against this hazard.

The most prominent hazard of a straddle crane is a blind zone that allows the wheels to crush workers who are unaware of crane movement. (See [Appendix A, Section 4\(a\)](#) for a list of cases.) When the operator’s station is not

on the top of the straddle crane where he or she can see all four wheels, the requirement for safety devices is clear. Safer alternate design requires closed circuit TV monitors, near object detection and travel alarms, and wheel guards/emergency stop systems. Closed-circuit video systems for security cost less than \$300 and become a low-cost method of blind-zone elimination.



Section 5: Inadequate Access

The safety of an operator begins with stable access to their post. Different types of cranes present different access hazards. (See [Appendix A, Section 5\(a\)](#) for unsafe access cases.) Hazards unique to crane type are presented as follows:

Latticeboom cranes: These large cranes often have an “A” frame to raise the boom supporting pennants above the level of the cab. This frame must be assembled with workers on top of the crane cab. (See Illustration 2.) Workers need fixed ladders and protective railing to climb onto the crane cab safely.

Tower cranes: Tower cranes several hundred feet high could, in some circumstances, be equipped with a walkway from the building under erection or an elevator within the main shaft to increase the safe access of the tower crane operator. To avoid a long climb for a restroom break, some cranes have attached a portable toilet to the top of the counterweight boom of hammerhead tower cranes.

Aerial lifts: Traditional design of aerial lifts creates the hazard of difficult and awkward access into the operator’s bucket. A gated basket would alleviate the unsafe and awkward access created by the usual practice of climbing over the top of the basket and into the deep well of the basket. The route to the basket should include railings as needed.



Other Crane Hazards

The following list provides a brief summary of other principal hazards to cranes:

- ◆ A thin sheet metal cab or no cab to protect the operator in the event of a falling object or upset is a persistent hazard. The Society of Automotive Engineers (SAE) has not as yet published a standard for protective operator cabs on cranes with operators' cabs situated on a turntable. This widespread hazard is addressed further in Part II, Section 5 of the HIFI study entitled "Inherently Safer Design Principles for Construction."
- ◆ Latticework boom cranes present a devastating hazard from incorrect disassembly of the boom. Some 65 deaths have been attributed to this hazard[~] (see also [Appendix B, Section 1](#) for a list of cases). When the unsupported boom is in a level position and someone knocks out the connecting pin on the lower side of the boom, it hinges open and collapses. This hazard deserves an alternate safer design that may include a hydraulic ram to open and close the butt section of the boom, lowering other sections of the boom to the ground as in Illustration 26.

Illustration 26: Alternate safer design for boom disassembly

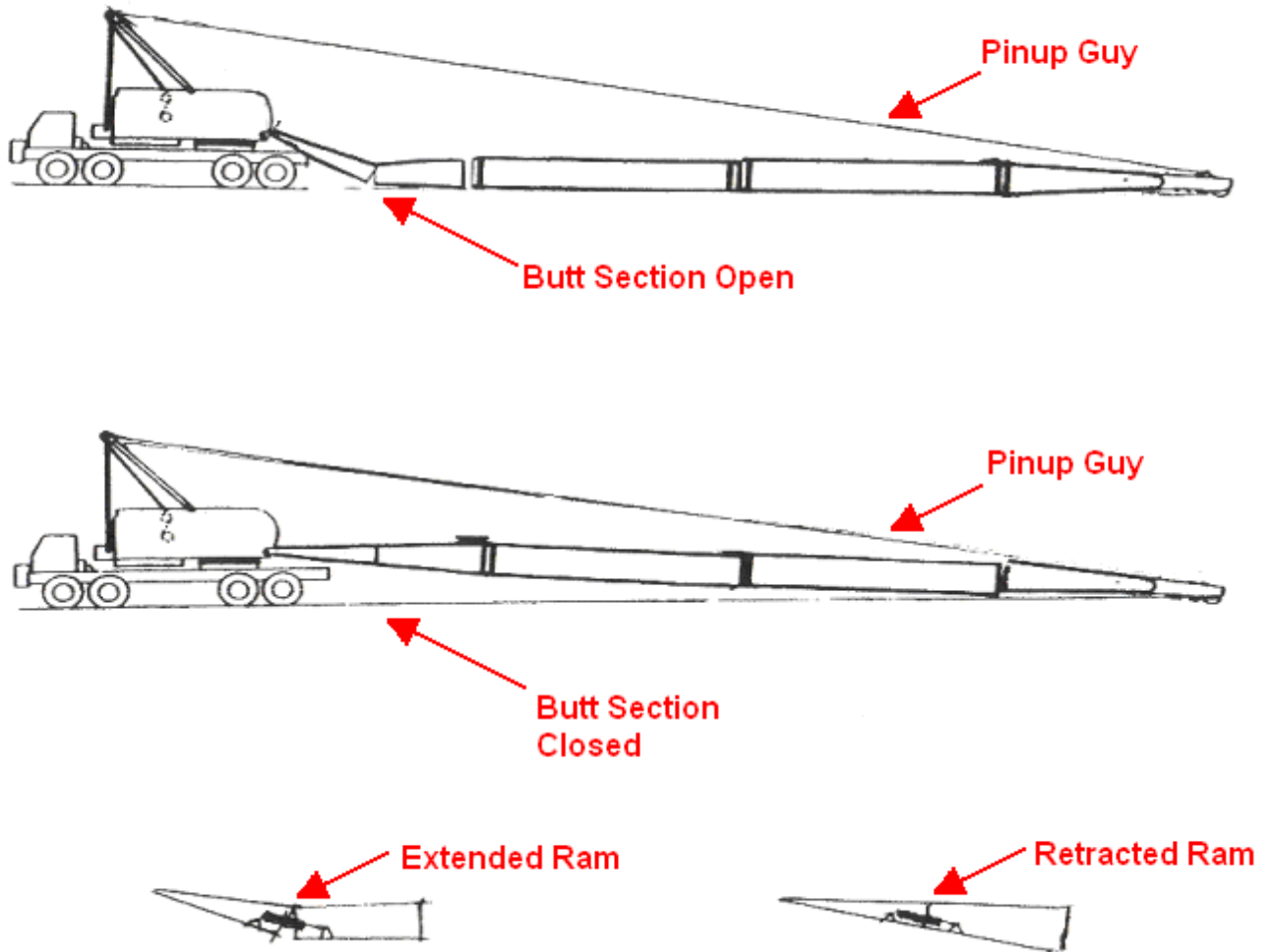

- ◆ Jib boom stowage on hydraulic telescoping booms presents another prominent hazard. A jib boom stowage system that relies upon manual pin placement results in the falling object hazard of the jib boom falling free. When the heavy (approximately 2,000 lbs.) jib boom falls due to improper stowage, it may strike someone, causing serious injury or death. This hazard occurs when jib stowage is attempted with the use of a pin to anchor the jib to the

side of the main hydraulic boom, as it is often misaligned with the anchor pin holes. (See [Appendix B, Section 2](#) for a list of cases.)

Correct stowage of the boom is dependent upon error-free alignment of the anchoring pin holes, which can be difficult to visually verify. Misalignment of the pin in the proper hole leaves the jib boom susceptible to falling from the intended anchor point.

There are five redundant safeguards that will control and reduce this hazard:

- Provide a separate automatic latching device to secure the jib boom when it is swung into the stowage position. This latching device needs to be a bar that allows the jib boom tip to slide into a secondary latch.
- Provide a ramp curb rail to slide a secondary latch onto the jib boom for a forked metal guide that will ensure for a positive snap and engagement onto a vertical bar.
- Create alignment marks clearly visible for the crane operator at the control station to confirm that the pin is properly aligned with the anchor pin holes. These alignment marks will make sure the anchor pin secures the jib boom in the secured position.
- Design a single hinge pin that secures the jib boom onto the outer hydraulic telescoping boom in its lifting capacity so that

it cannot be removed until the jib boom is locked in its stowage position.

- The operator station should have a sturdy cab to protect against falling objects in the event that the jib boom is not properly secured and falls free.
- ◆ Self loading and unloading of load counterweights is a complex process discussed in the operator's manual. When not followed correctly, injuries can occur. A simple approach to safely control the lifting of counterweights is to attach lifting hooks to them and use another crane for their addition or removal. (See [Appendix B, Section 3](#) for a list of cases.)
- ◆ Track-mounted fixed boom tower cranes have two unique hazards: operator access and a need for travel alarms and other forms of pedestrian protection.
- ◆ Bridge cranes have the following inherent hazards (See [Appendix B, Section 4](#) for a list of cases):
 - The need for a convenient lockout system
 - Unsafe access
 - Alternate control systems for multiple hoist drums to accommodate clamshell or other types of lifting
- ◆ Tower cranes have the following inherent hazards:

- Inadequate tower footing can cause the tower to tip, requiring disassembly of the entire structure, as a tower crane cannot function as a leaning tower.
- ◆ Self-raising mobile tower crane systems are often hazardous and require following a very complicated procedure. ([See Appendix B, Section 5](#)) Self-erection cranes are currently a “cross-breed” design, which does not completely fit into the Mobile Crane standard of ANSI B30.5 or the Tower Crane standard of ANSI B30.3. This lack of distinction has caused confusion and the stifling the use of self-erecting tower cranes in California, when a tower crane collapse in San Francisco that killed five people and injured 21, following two tower crane collapses in Los Angeles in 1981 & 1985, sparked statewide regulations that required a permitting process to erect a “tower crane.” In 2006 a fatal tower crane collapse occurred in Bellvue, Wash., which led to the state of Washington enacting a crane safety law early in 2007. The law called for annual inspection of cranes by third parties and the licensing of all crane operators. These regulations negate the time and cost savings that self-erecting crane technology can bring to a contractor. There are currently only approximately 400 self-erecting tower cranes in the U.S.

A European manufacturer of tower cranes has adopted the United Kingdom’s 1994 “Risk Assessment Procedures” where they

attempt to list everything possible that can go wrong and eliminate or minimize those risks. This is a positive step toward system safety, as the process mimics system safety concepts first developed by the Boeing aircraft company during WWII and formalized in US Military Specifications during the period of 1963-1969.

The Five Principles of Inherently Safer Design provides a transition process whereby a systems approach can be applied to construction and to the erection process for self-erecting tower cranes. What is needed is a manufacturer's certification that the self-erection process relies upon hazard control by elimination, guarding, use of safety factors, and redundant physical design safeguards to overcome hazards. Current reliance of user adherence to warning labels or complicated written operating procedures makes no allowances for foreseeable user mistakes and leads to recurring incidents. The concept of a self-erecting tower crane is the result of creative design engineering and should include design features to ensure that the tower and boom sections unfold automatically. This design theory should not provide the opportunity for the untrained and inexperienced worker to set up or dismantle a self-erecting crane. An alternate approach to proper mobile tower crane erection involves manufacturer collaboration with trainers and users to certify crane operators with a license to

erect and dismantle this piece of equipment. Such a certification program would work in conjunction with training for load moment indicators in self-erecting cranes to avoid modes of operation that lead to upset or collapse. Operators certified in tower crane assembly and use of LMIs are important parts of safer construction.

With this emergence of proactive crane safety, the ball is in the court of the manufacturers, distributors, and rental agencies. These entities have the responsibility to ensure for safe design and licensing of erectors. They should act immediately and independently and not wait for future standards or legislative governmental supervision.⁷

- ◆ An open hook, often characterized as a “killer hook” on a crane, often lacks an effective latch and allows the strap or chain to slip out of the throat of the hook. ([See Appendix B, Section 6.](#))
- ◆ The fall block (pulley) usually has an unguarded sheave, which provides the opportunity for anyone attempting to handle the block to have their hand caught in the nip point where the cable contacts the sheave. An obvious design improvement is to provide a handle on each side of the block.
- ◆ Two-blocking ([See Appendix B, Section 7.](#))
- ◆ Cranes create two significant pinchpoints. ([See Appendix B, Section 8.](#))

⁷ For further discussion on this subject, the cover story, “Defining Self-Erectors” by Phil Bishop, *Lift and Access*, March 2007 gives an excellent overview of the applications of self-erectors.

- The narrow clearance between the crane's truck bed or crawler tracks creates a pinchpoint that has resulted in a number of injuries. (See illustration on page 69 of *Crane Hazards and their Prevention*.) Counterweights can also create a deadly pinchpoint.
- The positioning of a crane next to a fixed object such as a tree, wall, or other vertical abstraction creates a whole-body pinchpoint between the rotating counterweight and the fixed object. (See illustration on page 68 of *Crane Hazards and their Prevention*.)



Other Aerial Lift Hazards

Scissor lifts have four other basic hazards ([See Appendix C, Section 1](#) for a list of cases):

- ◆ Self-propelled scissor lifts can upset when one wheel drags into a floor pot hole. Some models have very close ground clearance, which prevents upset in the event that one wheel falls into a pothole.
- ◆ For high-reach scissor lifts, automatic outriggers must be present to increase stability and prevent upset. Automatic outriggers should be incorporated into the design to enforce extra stability when the boom is raised.
- ◆ The transport of scissor lifts is another hazard. Driving them up a ramp onto a trailer or a flatbed truck can lead to upset. Trailers that drop to floor level are available and should be used to transport scissor lifts.
- ◆ The compromise of operator controls, as previously discussed, remains a persistent hazard.



PART III

Discussion

An admonition by Admiral Rickover, developer of atomic power for submarines and aircraft carriers, reminded us to “First identify all the ways that the atomic submarines can fail and then design them so they cannot fail.” Such attention to detail is the technical necessity that made nuclear power possible. Applied to the design of cranes and aerial lifts, such detailed hazard anticipation can prevent many hazards from becoming reality. Careful planning of equipment and project features is the key to maintaining a zero-failure performance and a profitable construction operation.

Yet design errors remain pervasive throughout the construction industry. The July 3, 2006 issue of *Engineering News Record* editorial entitled “Today’s Equipment has too many Shades of Gray” calls attention to the epidemic of unsafe features on construction equipment manufactured and sold worldwide. To move forward on safer cranes and aerial lifts (as well as other construction equipment), we must look beyond safe work practices and forge upstream to rethink construction processes at the time of design. Involvement of engineers as the primary authority for safe design can eliminate many hazards by design or planning and aid in the selection of safer equipment to be used on the project.

The previously referenced study[~] presents a methodology on how to cultivate

and develop successful engineer involvement in inherently safer design and construction safety planning.

Engineer involvement has been long overlooked in terms of equipment and design safety. Unfortunately, engineers usually find themselves “outside the loop” when it comes to being the principal authority to ensure for hazard control by design. Modern civilization has immeasurably benefited from an engineer’s talent and expertise to apply scientific technology in the design of magnificent structures and marvelous machines. This talent should be tapped as a source of failure-free design expertise and zero-defect construction planning. The first step to improving the design of construction plans and equipment is to yoke the safe design ideas from engineers.

As cranes and aerial lifts become more sophisticated to meet specific needs of development, safety standards can lag until a high number of injuries demands a need for action. Rather than follow a methodology which relies upon injury and death to develop a design for safety, safety needs to be considered a design priority at the onset of every project and be considered in each new piece of construction equipment made. Currently, there are some dramatic new construction concepts being adopted to overcome the typical disconnects in the design-bid-build method. The process, becoming known as “Progressive Project Delivery” (PPD), creates opportunity for both the suppliers and manufacturers of equipment (such as cranes and aerial lifts) to discuss the project as peer reviewers in all stages of design and construction. Providing communication channels that focus on choosing the right equipment, available equipment safety

features, and the most cost-effective methods of equipment use achieves an unprecedented level of project collaboration and eases construction projects from one phase to the next. Delaying hazard identification in equipment until it arrives on the work site delays the construction process itself, as it can create the necessity for worker special training or installation of safeguards. Establishing peer reviews to specify potential pitfalls during the design stage of project planning can eliminate many hazards during construction. A great example of hazard elimination would be to bury the powerline on a construction site as a routine part of initial site preparation, rather than to wait until the final landscaping contract for the finished structure.

Illustration 27, the flow chart for a design-bid-build project, shows little opportunity to incorporate the expertise of the suppliers of cranes and aerial lifts or other experts with beneficial site input.

Illustration 27

Sequential Project Delivery

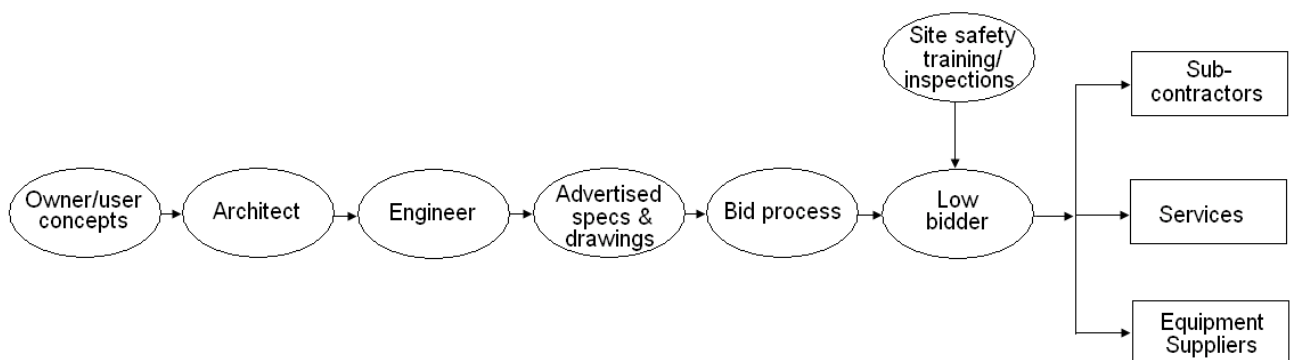
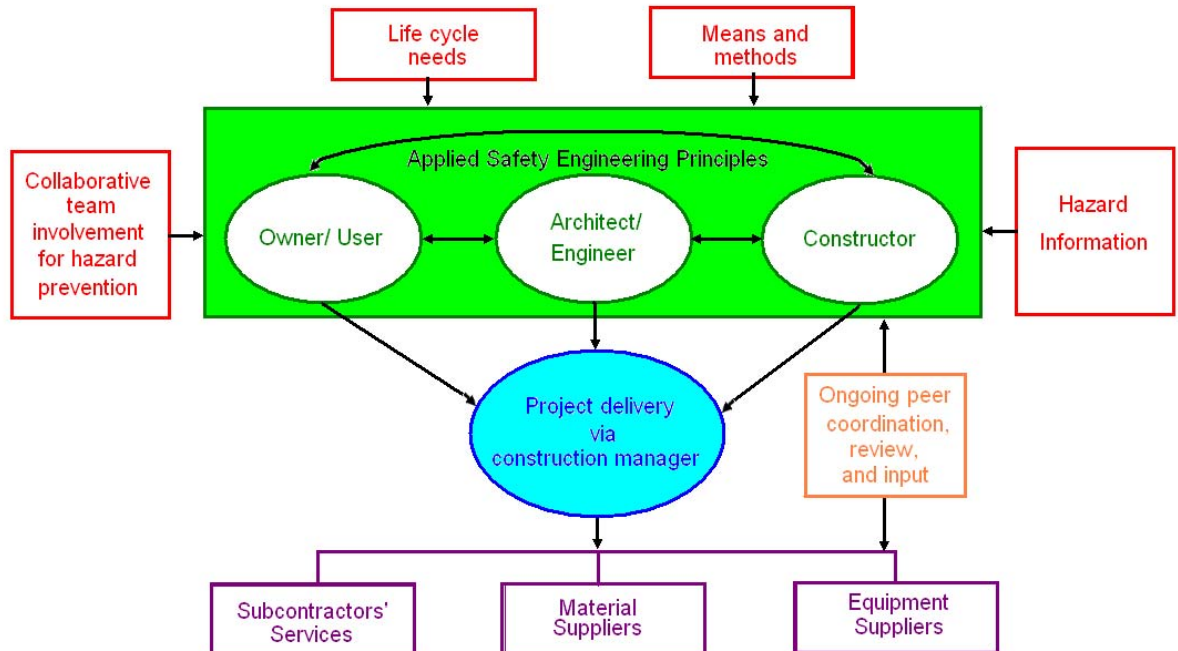

Illustration 28 shows an opportunity to incorporate peer advice from crane and aerial lift suppliers and other parties involved in construction.

Illustration 28

Progressive Project Delivery



With overview by equipment suppliers and collaboration of many parties during the planning process of a project, the use of cranes or aerial lifts adjacent to powerlines can be deemed an unacceptable construction method and easily avoided.



Five Principles of Inherently Safer Design

One potential method of achieving PPD is multi-party use of the Five Principles of Inherently Safer Design, mentioned previously in this study and outlined in the new book by McGraw-Hill, *Construction Safety Engineering Principles: Designing and Managing Safer Job Sites* (2007). This program has been adopted by construction giant Washington Group International (WGI), which is training 1,800 of their engineers in the five principles of inherently safer design. In addition to WGI's training, these design principles have been presented at national safety conferences⁸ and published in the May, 2006 issue of *Professional Safety*, the journal for the American Society of Safety Engineers (ASSE). Through emphasis on hazard identification in the initial stage, the Five Principles can be used as a reference point by owners, architects, design engineers, equipment designers, construction managers, and subcontractors during discussion and planning of the project. Further application is discussed below in a brief outline of each of the principles.

Principle One

Identify the hazard: Every hazard appears in one of three modes:

Dormant, when the hazard exists but is unable to cause harm; **armed**, when the

⁸ The Construction Safety Council, Chicago, IL February 2007; The Oregon Governor's Safety Conference, Portland, OR, March 2007.

hazard is in a situation where a change of circumstance could trigger the hazard to cause harm; and **active**, where the hazard is actively causing harm. The ability to identify hazards in the dormant mode is key to preventing them from becoming active and causing harm on a construction project. Overhead powerlines present a dormant hazard that becomes armed when boomed equipment is working next to it. This hazard becomes active when the equipment makes contact with the powerline, electrifying the metal parts with deadly voltage. PPD aids in identifying the presence of powerlines and potential controls in the planning stage by documenting all potential hazards from a variety of sources. The owner, architect and construction manager create individual lists of potential hazards on the same project, then match these hazards to hazards anticipated by sub-contractors, equipment rental firms, and other entities involved in the project. The result is a broad overview of many facets of potential hazards that can be planned around.

Principle Two

Establish a standard of care: When hazards are identified, it is imperative that the culture demands immediate hazard control. A popular safety tenet states “Any hazard that has the potential for serious injury or death is always unreasonable and always unacceptable if reasonable design features and/or the use of safety appliances are available to prevent the hazard.” This approach creates a priority for safety and prevents injuries and damage from occurring.

The creation of such a priority would invite the designer to include preventive designs in project plans to eliminate potential hazards, such as

removing all powerlines from a construction area. In the collaborative context of Progressive Project Delivery, it would create a guiding priority and a common goal to unify the myriad voices involved in the project.

Principle Three

Categorize the Hazard: Each hazard can be classified according to its nature into one of seven categories. Placing the hazard into its appropriate category helps determine methods of its control. In PPD, this categorization is helpful as a first step in determining the significance and classification of the hazard.

Accomplishment of this step means arriving at an agreement in a multi-party setting.

The seven categories of hazards are as follows⁹:

- Natural
- Structural/Mechanical
- Electrical (Powerlines are an electrical hazard)
- Chemical
- Radiant
- Biological
- Automated Systems

⁹ The textbook *Construction Safety Engineering Principles* (MacCollum, 2007) includes numerous sub-topic classifications of hazards for each category.

Principle Four

Use the Engineers' Safe Design Hierarchy to physically control hazards: It is not the role of the engineer (designer) to rely upon warnings and operating instructions as a substitute for the use of safety features. However, this sequence is also helpful in agreeing upon a path of efficient hazard elimination and designating responsibility in a multi-party setting. The following hierarchy of engineering control for hazards has become the accepted sequence for evaluating design for the prevention of hazards:

1. Elimination of the hazard (relocation of powerlines)
2. Guarding to prevent the hazard from causing harm (insulating link guards against electric shock)
3. Including safety factors to minimize the hazard (A range-limiting device to control boom movement within a safe envelope to disallow contact with a powerline brings the chance of powerline contact down to zero.)
4. Using *redundancy* for a group of parallel safeguards requires multiple levels to be breached before a harm-causing failure mode occurs.
(Relocation or de-energization of powerlines, along with use of an insulating link to guard, proximity alarm to warn, and use of a range limiting device provides redundancy to the degree that it is virtually impossible to accidentally contact a powerline.)

Principle Five

Control the hazard with the appropriate design improvement or safety appliance: Once a hazard has been identified, categorized, and a correct procedure for control established, it is easy to design out the hazard before it can cause harm. A “Hazard Identification and Prevention Matrix,” pictured in Illustration 29, is used to assist the design engineer in determining the necessary safeguards. The matrix will provide a worksheet for the engineer, architect, owner, sub-contractors, rental agencies, and other involved parties to couple hazards with design controls. It is the first step to visualizing hazard control measures, as the matrix provides an immediate connection between a given hazard and its necessary control. Rounding out the process of elimination of hazards by design, completion of the matrix forces collaborating parties to examine different methods of hazard elimination. Discussion of these matrices allows the group to settle on the most efficient, cost effective method of hazard control and designates responsibility of execution.

Illustration 29

	Eliminate the Hazard		Guard the Hazard		Provide a Safety Factor		Provide Redundancy		Provide Reliability
	Hazard	Safety	Hazard	Safety	Hazard	Safety	Hazard	Safety	
Natural									
Structural/Mechanical									
Electrical									

Chemical									
Radiant Energy									
Biological									
Automated Systems									



Incentives

Adoption of safety by design programs provides many financial rewards. Money saved by considering safety at the time of design can decrease the bottom-line cost of construction. The preparation of a bid proposal for a construction project is a speculative process. The contractor's bid includes a profit margin that is above the net cost. The involvement of engineers to examine safer construction methods and employ the use of safety appliances and safer design could reduce costly compliance with worker safety requirements. An example of this type of construction is when the roof trusses and decking are assembled on the ground of a worksite as a fall protection measure. After work is complete, finished roof sections are lifted into place by crane. This safer construction method saves costs by reduction of man hours and fewer personal protective devices for employees, such as the fall safety compliance cost of safety lines and body harnesses. Relocation of powerlines by burying them

before construction begins provides unobstructed use of a crane for lifting the roof sections and other materials into place. Further alteration of the design could provide a parapet around the edge of the flat roof, which eliminates the need for temporary parameter guarding. Costs can be dramatically reduced by the involvement of project engineers who estimate the cost, persons responsible for purchase of components, and construction management personnel who ensure that design and build projects include safety as part of their value. When the price of a project is \$1,000,000 including a 7% profit, the net price is \$930,000. If the net costs of such a project were reduced to \$750,000 through the application of safer design measures, the 7% profit margin would be \$52,500, resulting in a bid price of \$802,500. This reduced bid price provides an effective, competitive design and build construction cost compared to what was initially a \$1,000,000 project.

The cost of component features of a design and build project provides another opportunity for safety savings. Consider employer costs of annual hearing examinations and ear protection for the exposure of 100 people to an air compressor which operates at 95 Db and costs \$10,000 when compared to an air compressor which operates at 80 Db and costs \$50,000. Though the quieter compressor costs more at the initial output, the savings accrued by the elimination of the hearing examinations, disability claims, and hearing protectors could exceed \$40,000 in the next 15 years. If the machine has a life cycle of 30 years, the next 15 years would see spending another \$40,000 on corrective action to counteract the danger created by the noise of the inexpensive air

compressor. In this example, the initial output of \$50,000 to purchase a safe air compressor represents a savings of \$40,000 over a 30 year period. As illustrated, application of these integrations at the time of design would save a project literally thousands of dollars.



Conclusions

On a near-monthly basis, a major crane or aerial lift failure adds another catastrophe to a long list of incidents. Sometimes, these tragedies attain the limelight of national attention. Usually such media attention is short-lived, and nothing happens to address prevention of such occurrences. An exception to the return of the status quo was achieved through legislative action in the states of California and Washington. These states have both recently passed tough laws requiring annual crane inspection and crane operator licensing after two horrendous crane accidents occurred. (In these two states, the focus is primarily on tower cranes.) If such inspections had been in place before the failure of the crane, the loss of life, loss of property, and millions of dollars worth of litigation could have been avoided.

In the technologically-bounding world of the twenty-first century, we do not have the luxury to wait for more crane disasters, slog through administrative rulemaking processes, and wait for accident-inspired laws to take effect. The construction industry must be creative and fast-thinking if they are going to

successfully compete in the fast pace of the global market. Concepts in safety engineering bring new machines and applications to construction on an almost daily basis. Prevention afforded by this method is the only way to stay abreast of the monumental disasters that can be created by the incredible technological advances of the past decades.

We must look upstream to ensure that the life-cycle of the crane includes maintainability and failsafe assembly/disassembly procedures. Routine inspection and maintenance plays a vital role. Third-party competent inspectors and operator licensing strives for continuous improvement of performance, leading to fewer deaths and injuries from crane and aerial lift operations. Accountability can be achieved in the design, maintenance, and use of cranes and aerial lifts if every party involved makes prevention a priority.



Appendix A: Litigated Cases

Appendix A, Section 1(a)-1

COURT AND CASE NUMBER: Court of Common Pleas, Erie County, PA,
2289-A-1989

DATE OF OCCURRENCE: May 28, 1987

DATE COMPLAINT FILED:

EQUIPMENT/FACILITY: Crane

HAZARD: Powerline Contact

AVAILABLE HAZARD PREVENTION:

- ◆ Proximity alarm
- ◆ Range limiting device

SUMMARY OF OCCURRENCE: Two workers were killed during a “pick and carry” operation when the crane hoist line contacted a 7,200 V powerline that ran by a construction site inside the fence.

Appendix A, Section 1(a)-2

COURT AND CASE NUMBER: US District Court, District of Colorado # 83-F-2344

DATE OF OCCURRENCE: December 8, 1980

DATE COMPLAINT FILED: 1983

EQUIPMENT/FACILITY: Crane

HAZARD: Powerline Contact

AVAILABLE HAZARD PREVENTION:

- ◆ Proximity alarm
- ◆ Insulated link

SUMMARY OF OCCURRENCE: A worker was electrocuted while guiding the boom of another crane being loaded onto a flatbed truck. The hoist line of the lifting crane struck a 7,200 volt powerline and the current traveled down the hoist line, through the crane being lifted, and killed the worker. Another individual assisting in guiding the other end of the boom was unharmed.

Appendix A, Section 1(a)-3

COURT AND CASE NUMBER: Circuit Court, Perry County AL #CV-99-125

DATE OF OCCURRENCE: June 22, 1998

DATE COMPLAINT FILED: 1999

EQUIPMENT/FACILITY: Hydraulic Crane

HAZARD: Powerline Contact

AVAILABLE HAZARD PREVENTION:

- ◆ Proximity alarm
- ◆ Range limiting device
- ◆ Insulated link

SUMMARY OF OCCURRENCE: A worker was using a drill rig powered by an electric cable protected by wire webbing. A crane was in contact with this cable when its hook carrying metal wire straps struck a powerline. He sustained a shock and died.

Appendix A, Section 1(a)-4

COURT AND CASE NUMBER: Circuit Court, Hale County AL CV-90-75

DATE OF OCCURRENCE: April 9, 1990

DATE COMPLAINT FILED: 1990

EQUIPMENT/FACILITY: Crane

HAZARD: Powerline Contact

AVAILABLE HAZARD PREVENTION:

- ◆ Proximity alarm

SUMMARY OF OCCURRENCE: A worker was electrocuted when he was off-loading machinery. Powerlines were new and not considered to be energized. The hoist line struck the powerlines, and the worker fell down touching the outriggers. They were electrified and continued to shock him for up to five minutes before the cable hoist disengaged from the powerline.

Appendix A, Section 1(b)-1

COURT AND CASE NUMBER:

DATE OF OCCURRENCE: May 1, 2002

DATE COMPLAINT FILED:

EQUIPMENT/FACILITY: Aerial lift

HAZARD: Powerline Contact

AVAILABLE HAZARD PREVENTION:

- ◆ Contract requirements to trim trees before work begins
- ◆ Insulated basket cage
- ◆ Proximity Alarm

SUMMARY OF OCCURRENCE: The injured man was installing fiber optic cable from an aerial lift mounted on a truck. Branches of Redwood trees obscured the view of a high voltage cable. As the operator maneuvered the lift around the redwood trees, the lift or the operator contacted the 12,000 volt powerline. His injuries rendered him quadriplegic and necessitated the amputation of both arms. The following parties were involved: The electric utility, who did not trim the redwood branches on the powerline right of way. Also involved was the telephone company, who contracted a cable TV company, who retained a construction company to install the cable. The construction retained a service organization to provide traffic control, who failed to provide flagmen and signaling. Contractor selected an uninsulated truck that was unsuitable for use near powerlines. Apparently the immediate employer failed to fulfill the contract safety requirements for a signal person to guide the movement of the truck-mounted aerial lift, and was also named as a defendant.

NOTES: The use of conductive uninsulated boom aerial lifts has previously been the source of litigation due to incidents of powerline contact. The five following examples show a range of causes and consequences of aerial lift powerline contact. This case, totaling \$23 million, serves as an example of how liability can be apportioned to multiple parties for millions of dollars apiece. All defendants in this case recognized that their negligence was inexcusable and paid damages. Subrogation of \$6 million in workers claim funds was waived, for a total payout of \$29 million dollars.

TUIAKI - PARTIES FLOW CHART

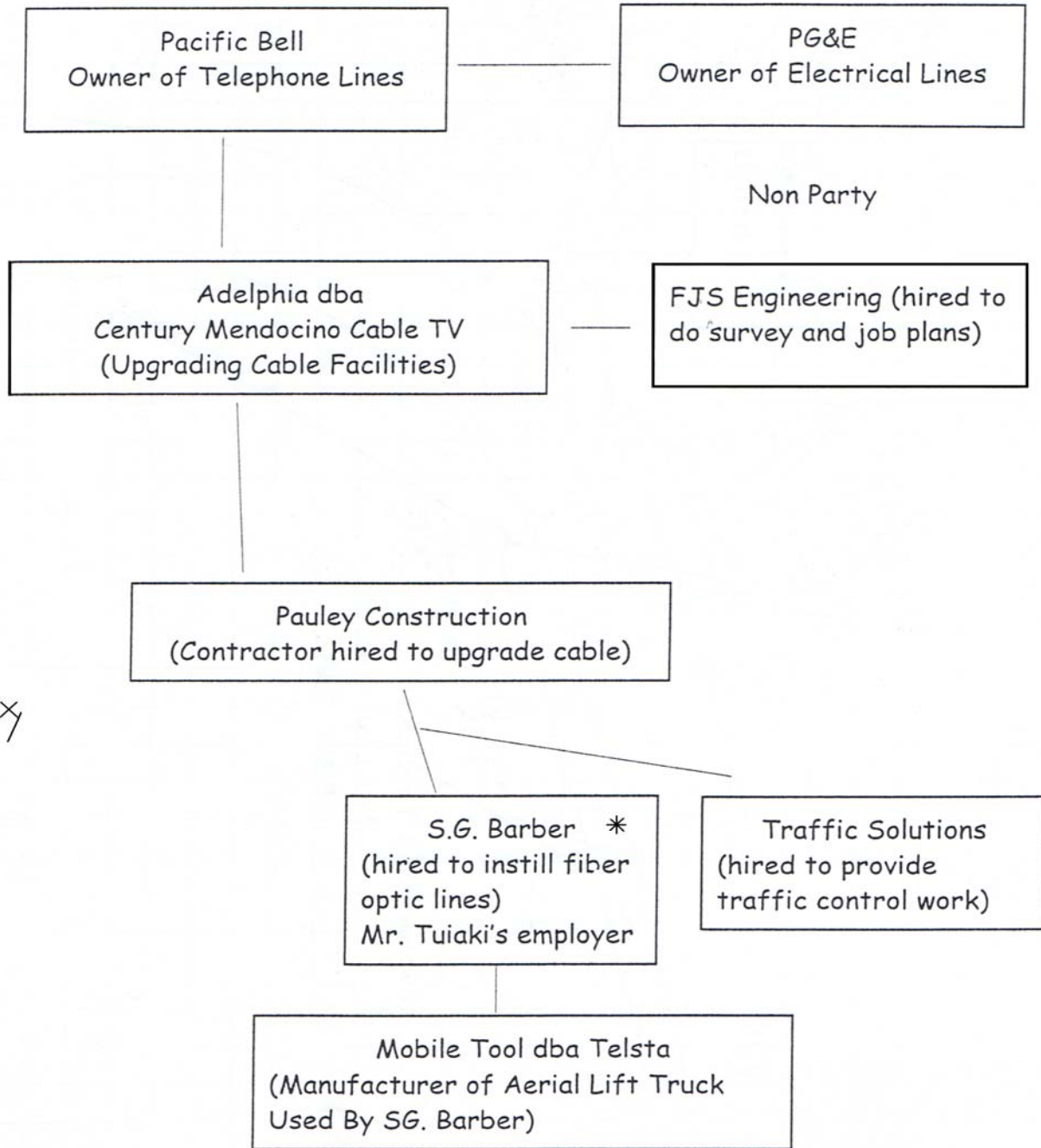

* Failed to provide an insulated aerial lift. The \$6 million subrogation claim was waived.

Appendix A, Section 1(b)-2

COURT AND CASE NUMBER: Multnomah County Circuit Court, OR; #A8603-01264

DATE OF OCCURRENCE: October 28, 1985

DATE COMPLAINT FILED: Amended August 15, 1990

EQUIPMENT/FACILITY: Aerial basket

HAZARD: Powerline Contact

AVAILABLE HAZARD PREVENTION:

- ◆ Insulated control handle
- ◆ Proximity Alarm
- ◆ Fully insulated basket and boom

SUMMARY OF OCCURRENCE: Deceased was in an uninsulated aerial basket. He swung 180 degrees into the powerline at night to repair an overhead conveyor and contacted the line.

NOTES: This aerial lift had an articulated boom

Appendix A, Section 1(b)-3

COURT AND CASE NUMBER: Circuit Court, Pulaski County, AR 82-0921

DATE OF OCCURRENCE: June 25, 1980

DATE COMPLAINT FILED: 1982

EQUIPMENT/FACILITY: Aerial lift work basket

HAZARD: Phase to phase powerline contact

AVAILABLE HAZARD PREVENTION:

- ◆ Insulated controls, jib boom and steel framework supporting the operator's basket to eliminate phase to phase contact.

SUMMARY OF OCCURRENCE: A tree trimmer was burned when the power saw blade touched a powerline and the uninsulated control in the basket of the aerial lift allowed a phase to phase electrical fault. The landowner was found negligent, as he should have requested an electric utility to do the tree trimming.

NOTES: In the 1970s a number of insulated aerial lifts used by linemen had a conductive control that was attached to the exposed metal framework supporting the basket and a metal jib boom. These conductive properties invited the possibility of a phase-to-phase contact when the lineman operated the aerial lift. Hopefully, these machines are no longer in service, or have been equipped with insulating materials and the current products have overcome his hazard by alternate design.

Appendix A, Section 1(b)-4

COURT AND CASE NUMBER: Court of Common Pleas, Allegheny County, PA
#82-1488-11265

DATE OF OCCURRENCE: August 31, 1981

DATE COMPLAINT FILED: October 1982

EQUIPMENT/FACILITY: Telescoping boom aerial lift

HAZARD: Powerline Contact

AVAILABLE HAZARD PREVENTION:

- ◆ A protective, non-conductive cage on the aerial lifts would have prevented contact of the deceased with the powerline.
- ◆ A proximity alarm to advise firemen of the location to live powerlines not yet de-energized by the electric utility could have prevented the contact.

SUMMARY OF OCCURRENCE: A fireman was electrocuted when he was working from an elevated platform and contacted an overhead powerline when maneuvering the boom to direct the water stream from the boom-mounted fire hose.

NOTES: A number of municipal fire departments have installed proximity alarms on their boom fire trucks for the purpose of warning them that powerlines have not been de-energized by the electric utility.

Appendix A, Section 1(b)-5

COURT AND CASE NUMBER: Circuit Court, Cook County, IL; Law Division
#77L 337

DATE OF OCCURRENCE: May 19, 1976

DATE COMPLAINT FILED: 1977

EQUIPMENT/FACILITY: Fire truck with telescoping ladder and basket

HAZARD: Powerline Contact

AVAILABLE HAZARD PREVENTION:

- ◆ Proximity alarm
- ◆ Insulated cage for the aerial basket

SUMMARY OF OCCURRENCE: A volunteer fireman was moving a flag from the top of a flagpole using a metal ladder fire truck. As he raised the boom to reach the flag, his head touched a powerline and he sustained horrible injuries. It was alleged that the boom should have a proximity alarm.

NOTES: Trial discovery investigation revealed that the fire truck dealer was aware that many fire ladder trucks were being equipped with proximity alarms but deliberately withheld this information to the purchasing agent.

Appendix A, Section 1(b)-6

COURT AND CASE NUMBER: State of North Carolina, General Court of Justice,
County of New Hanover # 94-CVS-997

DATE OF OCCURRENCE: February 1, 1993

DATE COMPLAINT FILED: 1994

EQUIPMENT/FACILITY: Non-insulated aerial lift used in a movie lot to construct and remodel sets from the service area, which was behind the set and contained overhead powerlines that supplied power to all the movie sets.

HAZARD: Operator of the aerial lift made contact with a 7,200 volt powerline in a work area that was in the danger zone.

AVAILABLE HAZARD PREVENTION:

- ◆ The hazard could have been eliminated at the time of construction by simply following the suggestions of the power company to bury the powerlines.
- ◆ The aerial lift should have been equipped with a non-conductive boom with an insulated basket. An insulated basket with a non-conductive frame of plastic piping would have guarded the operator from contacts with the powerline.

SUMMARY OF OCCURRENCE: The aerial lift operator sustained serious head, shoulder and arm burns when he raised the lift into an overhead powerline while working on remodeling a movie set from the service area at the rear of the set. The injured party's burns were so disfiguring that he had to wear a sack over his head for three years so he would not frighten his wife and children while undergoing numerous skin graft operations. The injured did not see the powerline, as he was blinded when looking into the sun.

DISPOSITION: The jury verdict in July, 1999 ruled in favor of the injured. The insurer of the movie lot appealed the judgment to the North Carolina Supreme Court, and the verdict in behalf of the injured was upheld. The aerial lift manufacturer and rental agency settled prior to trial.

NOTES: This is an excellent example where the involvement of the landowner was needed to ensure for buried powerlines, so the movie lot would have been safe for its intended use. Further, the crane manufacturer and its dealer/rental agency had an aerial lift model with a non-conductive boom, which was suitable for use. The aerial lift manufacturer's sales literature and operating manual showed an illustration of the aerial lift in use under a powerline. They also made another model of the same lift that incorporated non-conductive booms, as used by electric utility linemen. Had a crane such as this been used, the powerline contact would not have caused injury.

Appendix A, Section 1(b)-7

COURT AND CASE NUMBER: Lorain County Court of Common Pleas, OH
02CV113622

DATE OF OCCURRENCE: June 17, 2000

DATE COMPLAINT FILED: 2002

EQUIPMENT/FACILITY: A steel conductive telescoping boom aerial lift was being used to lift a workman so he could retouch the mortar on a brick wall of a 1916 building that had 7,200 V powerlines located three feet from the wall.

HAZARD: Powerline contact (mid-span)

AVAILABLE HAZARD PREVENTION:

- ◆ The project planning needed to remove the powerlines before the contract for the repair of the brick walls was negotiated.
- ◆ The rental firm should not have provided the lift that was to be used in an unsafe location

SUMMARY OF OCCURRENCE: An eighteen-year-old apprentice working alone was provided the above described aerial lift with no prior training from his employer. The city, which owned the municipal utility company, was administering a federal grant for restoring the 1916 building. The supervising architect/engineer made no requirements for the powerline to be buried as a condition of the grant. The equipment rental firm was well aware that the lift would be used by an apprentice in a dangerous location. The injured is now a quadriplegic who requires a ventilator to breathe.

NOTES: The absence of safety planning to eliminate this work circumstance is reprehensible. Not only the immediate job supervisor, who allowed an untrained hand to work in a dangerous situation, but the city planners and grant engineer showed a gross disregard for worker safety, and are all responsible for the condition of this young, 18-year old apprentice.



Appendix A, Section 2(a)-1

COURT AND CASE NUMBER: 45th Judicial District Court of Bexar County, TX
#98-CI-10315

DATE OF OCCURRENCE: July 13, 1998

DATE COMPLAINT FILED: 1998

EQUIPMENT/FACILITY: Truck-mounted telescoping hydraulic boom crane

HAZARD: Upset

AVAILABLE HAZARD PREVENTION:

- ◆ LMI-trained operator
- ◆ Use of crane outriggers
- ◆ Project planning should have requested a detour on access roads

SUMMARY OF OCCURRENCE: Deceased truck driver was crushed by crane upsetting while he was off-loading concrete K-Rail barriers. The crane's outriggers were retracted. The construction superintendent had ordered side-by-side positioning of the truck next to the crane. The work site was a freeway being widened, and had access roads on both sides, which should have been used for public travel. The additional space would have allowed the crane operator to extend the outriggers. The crane operator failed to use the Load Moment Device (LMI)

Appendix A 2(a)-2

COURT AND CASE NUMBER: Superior Court, King County, WA # 86-2-00580-3

DATE OF OCCURRENCE: April 20, 1985

DATE COMPLAINT FILED: 1986

EQUIPMENT/FACILITY: Tower Crane

HAZARD: Upset during elevation by a jacking process which would insert mast sections.

AVAILABLE HAZARD PREVENTION:

- ◆ Investigation of this occurrence revealed that trained personnel were unavailable and in violation of the rental agreement, and the task was attempted without competent supervision.

SUMMARY OF OCCURRENCE: Injured man sustained psychological problems when the tower of the crane was being raised to a higher level. The crane operator was unaware that the raising crew had removed all the bolts from the turntable during the lifting process, resulting in the counterweight and boom trolled in a precarious balance on top of the crane tower. When the operator lifted the section to be inserted in the tower, the crane boom became unbalanced and fell 400 feet from the tower. Fortunately, the boom collapsed slowly and impaled the ground, protecting the operator who was confined in the cab. The work was being done on a Saturday morning, and no pedestrians were endangered.

Appendix A, Section 2(b)-1

COURT AND CASE NUMBER: 3rd Circuit, Madison County, IL #81-L-194

DATE OF OCCURRENCE: June 12, 1979

DATE COMPLAINT FILED: 1981

EQUIPMENT/FACILITY: Mobile aerial work platform

HAZARD: Upset

SUMMARY OF OCCURRENCE: Injured man fell and was seriously injured when the aerial lift upset. No interlocks or load moment device (LMI), which had been incorporated into the design. Inadequate recall program, as no registered letter was sent to purchaser. The owner's safety program did not restrict the use of the manlifts to their own "trained" employees. Instead, they left the key in the machine and were aware that contractors were using the equipment.

AVAILABLE HAZARD PREVENTION:

- ◆ Design should have included an LMI and interlocks to ensure that the aerial lift's boom movement would be restricted within its rated lifting capacity, when the outriggers are retracted or extended.

DISPOSITION: Settled during trial.

Appendix A, Section 2(b)-2

COURT AND CASE NUMBER: 17th Judicial circuit, Broward County, FL 85-14822-DB

DATE OF OCCURRENCE: June 16, 1983

DATE COMPLAINT FILED: 1985

EQUIPMENT/FACILITY: Aerial Basket/Manlift

HAZARD: Upset

AVAILABLE HAZARD PREVENTION:

- ◆ Provide reliable interlocks and LMIs to prevent boom movement that allows for upset

SUMMARY OF OCCURRENCE: The victim fell 17 feet when an aerial basket upset due to outrigger interlock failure. He hit his head and died.

DISPOSITION: Settled in March 1990.

Appendix A, Section 2(b)-3

COURT AND CASE NUMBER: Superior Court, 3rd Judicial District, AK 3AN—86-14126

DATE OF OCCURRENCE: August 21, 1989

DATE COMPLAINT FILED: 1986

EQUIPMENT/FACILITY: Mobile aerial basket

HAZARD: Upset

AVAILABLE HAZARD PREVENTION:

- ◆ Install interlocks and an LMI to prevent boom movement that creates an overload

SUMMARY OF OCCURRENCE: In 1979, two painters were using a self-propelled aerial lift. They overloaded the unit with extra paint buckets and failed to extend the outriggers. It was found that the aerial lift was without interlocks to prevent use of the boom when the outriggers were down but not extended. A lawsuit regarding a similar incident was filed against the same manufacturer.

A similar incident occurred in 1978. Depositions for the lawsuit filed in 1981 revealed 30 additional occurrences of upset due to a lack of limit switches to prevent boom movement when outriggers were not extended.

Just prior to the 1989 occurrence a factory rep was in Alaska. The aerial lift that had been designated for installation of new limit switches was being used in a location a mere few blocks from rental facilities was not examined. Testimony revealed that the factory rep whose visit was intended to ensure that all of the aerial lifts were retrofitted with interlocks to prevent use of the lift when the outriggers were retracted went on a salmon fishing tour with the rental agency instead of completing his assignment. His leisure activities prevented him from retrofitting the aerial lift with limit switches.

NOTES: The time lag of 10 years for retrofitting the aerial lifts is an unreasonable delay.

Appendix A, Section 2(b)-4

COURT AND CASE NUMBER: City of Phoenix, FaAA-AZ-R-95-5-5

DATE OF OCCURRENCE: February 11, 1997

EQUIPMENT/FACILITY: aerial lift basket

HAZARD: Upset/ Turret bolt failure

AVAILABLE HAZARD PREVENTION:

- ◆ Increase the diameter of the bolts. Bolts to $\frac{3}{4}$ " thickness would have double the strength of the standard $\frac{5}{8}$ " thickness bolts that were used.
- ◆ Improved design of the saddle and the securing system of the boom would prevent vibration.

SUMMARY OF OCCURRENCE: A worker was killed when the aerial lift boom separated from the turret and fell to the ground. The design of the turret assembly was insufficient for a 75 foot boom. A hydraulic release was needed, and the saddle anchor was insufficient to prevent turret bolt failure.

DISPOSITION: The manufacturer settled in 2001 with the city that owned the lift.

NOTES: The failure of 18 connecting bolts on the base of the boom from the turret shows fatigue cracking over a period of time. At the time of design, the turret for a 50-foot boom was used to support a 75 foot boom, which increases tension on the turret bolts. It appears that no attention was given to the saddle and anchoring system to hold the collapsed boom in the travel position. When the vehicle travels, normal vibration creates excessive tension on the turret bolts, which creates a progressive fatigue failure.



Appendix A, Section 3(a)-1

COURT AND CASE NUMBER: 14th Judicial District, Dallas County, TX #78-7097A

DATE OF OCCURRENCE: August 23, 1976

DATE COMPLAINT FILED: 1978

EQUIPMENT/FACILITY: Flatbed truck crane, dual remote control

HAZARD: Inadvertent activation of controls

AVAILABLE HAZARD PREVENTION:

- ◆ Provide a non-conductive remote control
- ◆ Provide reliable electrical control relays

SUMMARY OF OCCURRENCE: The crane operator was electrocuted while using an “umbilical cord” style conductive remote control. The boom responded erratically to his command and swung into a powerline. The conductive control cord was unsafe and the control system was defective because it did not obey the commands given.

NOTES: Some ten cases involving flatbed truck-mounted (boom elevation) trolley cranes have been documented. These trolley cranes are typically used to load and unload pallets of brick/concrete block of plasterboard and other building materials. They come equipped with a tether electric cable control that was inadequately designed with faulty relays, leading to failure. When the malfunction occurred, the boom would raise into a powerline. The immediate ground fault was through electric control tether, resulting in injury or death of the operator. This control system was replaced with a pneumatic non-conductive control system and more reliable relays that would not short out and weld shut. It remains unknown whether all these cranes were modeled with non-conductive remote controls or taken out of service.

Appendix A, Section 3(a)-2

COURT AND CASE NUMBER: Circuit Court, Douglas County, OR #77-0360

DATE COMPLAINT FILED: 1977

EQUIPMENT/FACILITY: Mobile hydraulic rough-terrain crane

HAZARD: Inadvertent activation of controls

AVAILABLE HAZARD PREVENTION:

- ◆ Locate the 4-wheel steer control away from steering wheel and provide a detent for activation
- ◆ Provide a crush-resistant operators' cab

SUMMARY OF OCCURRENCE: Deceased mechanic was driving a rig down a slope to shop at night. He lost control of the vehicle, assumedly by striking four-wheel steer. The crane went close to the bank of the slope and rolled over. The driver was crushed, as there were no roll bars to protect from being crushed between ground and boom. There was no pin in the turntable, which allowed the boom to rotate.

NOTES: Four rough terrain cranes with two/four wheel steer control had these controls located $\frac{3}{4}$ inches from the steering wheel. The location of the controls caused inadvertent activation to four-wheel steering by the operator's gloved hand, making the crane swerve severely when in the travel mode and resulting in upset.

Appendix A, Section 3(b)-1

COURT AND CASE NUMBER: US Eastern District Court, PA #87-5967 & #87-5644

DATE OF OCCURRENCE: April 25, 1986

DATE COMPLAINT FILED: 1987

EQUIPMENT/FACILITY: Aerial work platform/ manlift

HAZARD: Error provocative controls

AVAILABLE HAZARD PREVENTION:

- ◆ Controls should have been guarded.
- ◆ A new protective covering put on joystick controls to prevent the accumulation of dirt on the electrical contacts

SUMMARY OF OCCURRENCE: A worker was crushed to death between in an aerial work platform between its handrail and an overhead beam when accumulated dirt from sandblasting caused the control to malfunction.

NOTES: Scissor lifts with controls unprotected from overhead obstruction have been a repeated cause of entrapment of the operator. Aerial lifts used in functions such as sandblasting are known to contaminate the controls and cause creeping and unintentional activation.

Appendix A, Section 3(b)-2

COURT AND CASE NUMBER: US Eastern District Court, New York, No. 75 Civ
1080

EQUIPMENT/FACILITY: Aerial Basket/Manlift

HAZARD: Error-Provocative Controls

AVAILABLE HAZARD PREVENTION:

- ◆ Guarded controls
- ◆ Operator safety harness

SUMMARY OF OCCURRENCE: The control box containing the operating lever on an aerial lift was contacted an overhead wire, and the lever was locked into an “up” position. The basket shot up into the air and the worker was thrown onto the boom truck 40 feet below, sustaining head injuries.



Appendix A, Section 4(a)-1

COURT AND CASE NUMBER: Superior Court of New Jersey, Law Division,
Atlantic County # ATL-L-1380-04

DATE OF OCCURRENCE: May 14, 2002

DATE COMPLAINT FILED:

EQUIPMENT/FACILITY: Straddle Crane

HAZARD: Blind Zone

AVAILABLE HAZARD PREVENTION:

- ◆ The operator's cab should be relocated to the top of the straddle, where the operator could view all four wheels.
- ◆ If relocation is not an option, the use of closed-circuit TV, would improve vision
- ◆ Design should include "cow-catcher" type of wheel guards to push workers away from the wheel
- ◆ Travel alarms and sensors would warn the operator
- ◆ Automatic stopping mechanism would be a redundant safety feature.
- ◆ Ultra High Frequency (UHF) near-object detector

SUMMARY OF OCCURRENCE: A worker acting as a spotter and rigger for a 50-ton straddle travel lift crane was struck down and apparently run over by the right front wheel of the crane. The worker suffered severe injuries to his left leg and hip. Tire marks were noted on the worker's sweat pants on the left leg. He had a fracture on his left ankle and injury to his entire left leg from ankle to hip. The Certificate of Death indicates the following: "Multiple complications of multiple injuries with extensive pelvic fractures." The Cooper Hospital medical summary also indicates "left gluteal degloving injury and urethral injury" among its final diagnoses.

The crane's orientation is based on the operator's perspective when seated in the cab. This crane is approximately 42-feet wide by 30-feet long by 30-feet high, with the operator's cab on the left-hand side about 15 feet above the ground. When new, the crane was equipped with

wheel guards on the front and rear of all four wheels, a standard strobe light and a motion alarm to alert personnel that the crane was moving. At the time of the injury, the right front wheel was without guards, and the strobe light and motion alarm were not functioning.

NOTES: There are a number of circumstances where the straddle crane operator must cope with a blind zone. This case illustrates the instance of an operation that requires the crane operator to make a lift in a situation the operator must rely upon a signalman. This situation creates the single most recurring blind zone.

These straddle cranes are also used by the railroads for handling containers in their intermodal yards and have experienced injuries from the blind zones.







Appendix A, Section 4(a)-2

COURT AND CASE NUMBER: Circuit Court, Saginaw County, MI #82-08174
NO-4

DATE OF OCCURRENCE: June 12, 1980

DATE COMPLAINT FILED: February 5, 1982

EQUIPMENT/FACILITY: Straddle mobile gantry crane

HAZARD: Blind Zone

AVAILABLE HAZARD PREVENTION:

- ◆ Separately functioning reverse signal alarms on each leg of the straddle crane
- ◆ Improved mirrors to reduce the blind zone
- ◆ UHF near object detector or closed-circuit TV

SUMMARY OF OCCURRENCE: The injured worker suffered tissue damage when a mobile gantry crane backed over him. The crane's reverse signal alarm was malfunctioning, and the blind zone did not allow the crane operator to observe the injured worker's whereabouts.

NOTES: HIFI has 15 documented straddle crane blind zone injuries and deaths.



Appendix A, Section 5(a)-1

COURT AND CASE NUMBER: Circuit Court, County of Wayne, MI #93-305596

DATE COMPLAINT FILED: February 23, 1993

EQUIPMENT/FACILITY: Crane

HAZARD: Unsafe access, fall from elevation

AVAILABLE HAZARD PREVENTION:

- ◆ Ladder or walkway as a construction specification
- ◆ Train the construction manager on construction safety planning

SUMMARY OF OCCURRENCE: The injured worker was riding the load line of a crane (holding onto the swivel hook) to enter/exit a work site. The worker slipped and fell, causing permanent damage to the lower half of his body. The employer was a large homebuilding developer.

Appendix A, Section 5(a)-2

COURT AND CASE NUMBER: 17th Judicial Circuit, Broward County, FL #898-28470-CO

DATE OF OCCURRENCE: June 16, 1987

DATE COMPLAINT FILED: 1988

EQUIPMENT/FACILITY: 70 ton crane

HAZARD: Access/fall from elevation

AVAILABLE HAZARD PREVENTION:

- ◆ Seat belt
- ◆ Communication between truck driver and crane operator
- ◆ Roll down window in crane cab

SUMMARY OF OCCURRENCE: The injured worker sustained severe brain damage when he was thrown from the open cab of the truck mounted crane being driven to the work site with a latticework boom assembled and extended over the rear of the truck carrier. The crane operator remained in the cab so the boom could negotiate the narrow streets. When traveling down the freeway with doors open for ventilation in the hot June weather, the worker fell from the moving crane. A solid window in the door that could not be opened separately all contributed to this injury.

Appendix A, Section 5(a)-3

COURT AND CASE NUMBER: Judicial Court, Duval County FL, #78-8735-CA

DATE OF OCCURRENCE: July 29, 1975

DATE COMPLAINT FILED: 1978

EQUIPMENT/FACILITY: Mobile crane

HAZARD: lack of access/ fall different level

AVAILABLE HAZARD PREVENTION:

- ◆ Provide access consistent with SAE recommendations

SUMMARY OF OCCURRENCE: The injured worker fell when attempting to get off crane. Access was oily, and there was no clear route of access consistent with Society of Automotive Engineers (SAE) standards.



Appendix B: Litigated Cases, Crane Hazards

Appendix B, Section 1-1

COURT AND CASE NUMBER: 3rd Circuit Court, Madison County, IL #66-L-575

DATE OF OCCURRENCE: September 24, 1964

DATE COMPLAINT FILED: August 11, 1966

EQUIPMENT/FACILITY: Latticework boom crane

HAZARD: Boom collapse during disassembly

AVAILABLE HAZARD PREVENTION:

- ◆ Provide a power hinge on the boom.

SUMMARY OF OCCURRENCE: Worker was crushed by a falling boom when the support pins were knocked out during disassembly. He became paraplegic.

DISPOSITION: Settled June 2, 1971

NOTES: This was the first of some 65 similar cases referenced by HIFI

Trial Exhibit 208 Summary of Support from Proffer and Further Proffer *

1	A	B	C	D	E	F
	Accident Dates	Location	Name	Crane Type	Injury	* Proffer and Exhibit
2	07-May-63	Mcleod County, MN	Christensen, Pauline	FMC LS-78 Crawler Crane	Killed	I-L, II-P, II-M
3	24-Sep-64	Madison County, IL	Schicker, Charles	FMC LS 68X	Killed	I-L, II-P, II-M
4	05-Feb-72	Cook Co, IL	Turner, Michael	FMC LS-98 Crawler Crane	Injured	I-L
5	01-Mar-72	NY	Ambrosino, Anthony	FMC HC-108 Truck Crane	Killed	I-L
6	02-May-72		Wilmore, Donald	FMC		
7	05-Oct-73	Front Royal, VA	Turner, Eddie Lee	Bucyrus-Erie 25-B	Killed	I-B, Trial Ex. #90
8	10-Jan-74	Highpoint, NC	Ratliff, Guy Issac	Bucyrus-Erie 25-B	Killed	I-B, Trial Ex. #90
9	11-Feb-74	St. Francisville, LA	Morgan, Edward	Bucyrus-Erie 22-B Crawler Crane	Killed	II-J, II-K, I-G
10	17-Oct-74	Milwaukee, WI	Hanson	Bucyrus-Erie Model 65-C		
11	01-Jan-76	Houston, TX	Hernandez, Frank	FMC HC-58B Truck Crane		I-L
12	In 1976	Lubbock, TX	Godwin, Debra Jean	FMC HC-78C Crawler Crane	Killed	I-L
13	In 1976	Topeka, KS	Addington, Larry	FMC HC-78B Truck Crane	Injured	I-L, II-M, I-K
14						
15	01-Oct-76	Houston, TX	Rush, Wesley	Bucyrus-Erie 30 B Crawler Crane	Killed	I-G, II-J, II-K, I-B, I-D, I-E
16						
17	29-Jun-77	Dallas, TX	Hedgepeth, Ben	FMC HC-48A Truck Crane	Paraplegic	I-L, II-B, II-M, II-P, I-K
18	12-Apr-78	Brunswick, GA	Cook, B.	Bucyrus-Erie 30-B Crawler Crane	Injured	II-P, I-D, I-E
19	20-Apr-78	Volusia County, FL	Blythe, Kenneth Dale	FMC Model LS-98A 40 Ton	Injured	I-K, I-L, II-M
20	09-Jun-78	Gillette, AR	Fowkles, D.	Bucyrus-Erie 30-B Crawler Crane	Injured	I-D, I-E
21	10-Jul-78	Alberta, CA	Martin, Mel	FMC	Injured	I-K, I-L
22	05-Oct-78	Seattle, WA	King, Harley	FMC	Killed	I-K, I-L
23	05-Oct-78	Seattle, WA	Leota, Joseph	FMC	Injured	I-L
24	18-Oct-78	Sarasota, FL	Prosser, John	FMC HC-48 Truck Crane	Paraplegic	II-P, I-K, I-L
25	17-Apr-79	Polk County, FL	Sly, Earl Ross	FMC LS-98A	Killed	I-K, I-L
26	18-Apr-79	Great Lakes, IL	Vignochi, John	FMC	Injured	I-L
27	18-Apr-79	Great Lakes, IL	Gianorgi, Joseph	FMC	Injured	I-L
28	21-May-79	Lake Charles, LA	Williams, Arlen F.	FMC	Killed	I-L
29	12-Jul-79	Clay County, MN	Mauseth		Killed	II-B
30	05-Nov-79	Perth Amboy, NJ	Famula, William	Bucyrus-Erie 30-B Crawler Crane	Killed	II-J, II-K, I-G
31	17-Dec-79	Cook County, IL	Allbritton, Bobby	FMC HC-48A Truck Crane	Injured	II-B, II-M, II-P, I-L
32	12-Feb-80	MN	Ramaker, Neil	FMC	Killed	I-L
33	01-May-80	Hayward, CA	Lebic, Larry	FMC	Killed	I-L
34	06-Jun-80	Corpus Christi, TX	Martinez, Iris	FMC LS-118 Crawler Crane	Killed	II-M, II-N, I-K, I-L
35	25-Sep-80	Plant City, FL	Yancey, Jerry	Bucyrus-Erie 30-B Crawler Crane	Killed	I-D, I-E
36	07-Jul-81	Milwaukee, WI	Berg, Roger	Bucyrus-Erie 30-B Crawler Crane	Injured	I-D, I-E

**I" refers to Proffer

"II" refers to Further Proffer e.g. "II-Q" refers to Further Proffer Exhibit Q

Trial Exhibit 208 Summary of Support from Proffer and Further Proffer *

	A	B	C	D	E	F
1	Accident Dates	Location	Name	Crane Type	Injury	* Proffer and Exhibit
37						
38	22-Mar-82	Burnsville, WV	Lee, David Allen	FMC	Killed	I-L
39	18-May-82	Haddam Neck, CT	Benoit, Roger	FMC	Killed	I-L
40	21-Dec-82	Springfield, MO	Grass Ridge Industries Employee	FMC	Killed	
41	04-May-83	Mt. Hebron, MD	Keiter, Richard	Bucyrus-Erie 30-B Crawler Crane		I-D, I-E
42	28-Jun-83	Vernon, TX	Sullivan, Jerry	FMC	Killed	I-L
43	15-Aug-83	Ontario, Canada	Reeves, Randy	FMC	Killed	I-L
44	30-Aug-83	Houston, TX	Star Concrete Employee	FMC	Killed	
45	04-Nov-83	Allsip, IL	Wade, Lonnie	FMC	Killed	I-L
46	01-Jan-84		Bear, W.J.	Bucyrus-Erie		I-G
47						
48	26-Apr-84	FL	Strickland, Edward	FMC	Killed	II-C, I-L
49						
50						
51	16-Feb-85	Houston, TX	Garcia, Reynaldo	FMC LS-98A	Killed	II-D, I-K, I-L
52	15-Apr-85	Minneapolis, MN	Berens, Emmett	FMC	Injured	II-P, I-K, I-L
53						
54						
55	20-Aug-85	AL	Mulkey, Russell	FMC	Killed	I-L
56						
57						
58						
59						
60	27-Mar-87	Winnebago, MN	Gorder, David	Bucyrus Erie	Killed	II-E, I-G
61	04-Aug-87	Johnstown, PA	Chura, Allan	Bucyrus Erie 30-B	Killed	
62	25-Jan-88	AL	Williamson, Terry	FMC	Killed	I-L
63						
64	27-Jun-88	Bryan, OH	Burton, Bob	FMC	Killed	II-F, I-L
65	07-Jul-88	Columbia, TN	Harris, Tim	Bucyrus-Erie 30-B Crawler Crane	Killed	II-J, II-K
66						
67						
68	30-Jan-89		Quesada, Adam	FMC	Killed	
69						
70						
71	10-Aug-89	Okemah, OK	Heck, Roger	FMC LS 98A Crawler Crane	Killed	

**I" refers to Proffer

"II" refers to Further Proffer e.g."II-Q" refers to Further Proffer Exhibit Q

Trial Exhibit 208 Summary of Support from Proffer and Further Proffer *

	A	B	C	D	E	F
1	Accident Dates	Location	Name	Crane Type	Injury	* Proffer and Exhibit
72						
73						
74						
75						
76						
77						
78						
79	17-Mar-94	Brockport, NY	Underwood, Howard	Bucyrus-Erie 30-B	Injured	
80						
81						
82						
83						
84						
85						
86						
87						
88						
89						
90						
91						
92	02-Feb-01	Walnut Grove, AL	Robinson, Phillip Timothy	FMC Link Belt	Killed	II-G
93		Bethesda, MD	McKelvin, Oscar	FMC LS-108B Crawler Crane		I-K, I-L
94		Corpus Christi, TX	Solis, Leticia	FMC LS-108B Crawler Crane	Killed	I-K, II-M, I-L
95			Witt, Dennis	FMC LS-98A		I-L
96			Gomez, Francisco	FMC LS-98A		I-L
97			Mahdi, Talmadge	FMC LS-98A		I-L
98			Finley, Harold	Northwest Engineering	Injured	II-I, I-L
99		Jefferson Co, Tx	Stanley, Susan	FMC	Killed	I-K, I-L
100		San Pedro, CA	Byram, Daniel	FMC		I-K, I-L
101		St. Louis, MO	Mahaffey	FMC	Killed	
102		New Orleans, LA	Clark	Koehring		
103		IL	Gilroy	Northwest Engineering	Injured	II-L, II-P
104						
105	30-Sep-80	PA	Bell, Leonard	American Crane	Killed	II-L
106	31-Jul-89	Chautauqua County, NY	Stufflebeam, Randall	FMC	Injured	
107	ADDITIONAL OSHA refers to Proffer					

"II" refers to Further Proffer e.g. "II-Q" refers to Further Proffer Exhibit Q

Trial Exhibit 208 Summary of Support from Proffer and Further Proffer *

1	A	B	C	D	E	F
	Accident Dates	Location	Name	Crane Type	Injury	* Proffer and Exhibit
108	07-Sep-84	Cordele, GA	Johnny Daniel Construction Employee	FMC LS98 Crawler Crane	Killed	II-Q
109	17-Dec-84	Foosland, IL	Pyramid Construction Company, Inc. Employee	FMC Crawler Crane	Killed	II-Q
110	16-May-85	Indianapolis, IN	Dotlich Inc. Employee	BLH Linn 600T	Killed	II-Q
111	17-Jun-85	San Antonio, TX	Heath Contractors, Inc. Employee	FMC Link Belt LS 108B	Killed	II-Q
112	11-Jul-85	Ft. Worth, TX	Austin Bridge, Co Employee		Killed	II-Q
113	06-Sep-85	Miami, FL	Berkel & Company Contractors, Inc Employee	FMC Link Belt LS98A	Killed	II-Q
114	12-Mar-86	Trenton, NJ	Dermatos Enterprises, Inc. Employee		Killed	II-Q
115	02-Jun-86	Elmhurst, IL	Loiringor Mid-States Paving Company Employee		Killed	II-Q
116	12-Jun-87	Charlotte, NC	Blythe Industries, Inc. Employee		Killed	II-Q
117	19-Aug-88	Devers, TX	James Kaiser Construction Equipment and Maintenance Employee	FMC Link Belt LS-108B	Killed	II-Q
118	01-Jun-89	New Britain, CT	Arute Brothers, Inc. Employee	Bucyrus-Erie Crane	2 Injured	II-R
119	05-Feb-90	Memphis, TN	Hawkins Machinery Inc. Employee		Killed	II-Q
120	18-Apr-90	Minneapolis, MN	Layne Construction Company Employee	FMC Link Belt LS98	Killed	II-Q
121	19-Jun-90	Erwin, NC	Carolina Bridge Co. Inc Employee	Link Belt 45 ton	Killed	II-Q
122	17-Aug-90	Oxnard, CA	Ventura Co. Flood Control Employee		Killed	II-Q
123	10-Oct-90	Hartford, AL	Wayne Ford Contracting Inc.	Lattice Crane	1 Killed, 1 injured	II-Q
124	16-Jan-91	Missoula, MT	Structural Systems, Inc. Employee	Truck Crane	Killed	II-Q
125	18-Feb-91	Baltimore, MD	Mclsan Contracting Company, Employee	FMC HC218	Injured	II-Q
126	01-Apr-91	Houston, TX	Ramex Construction Employee	Lattice Crane	Killed	II-Q
127	13-Jan-92	Laughlin, NV	Postlewait, Inc.	Bucyrus-Erie 60 Ton Crane	Killed	II-S
128	14-Jul-92	Cockeysville, MD	Richard F. Kline, Inc Employee	FMC 5-108B	Killed	II-Q
129	15-Apr-93	Cleveland, OH	Arc Steel, Inc. Employee		Killed	II-Q
130	19-Apr-98	Cold Spring Harbor, NY	Thompson Bros Dook Builders Inc Employee	Truck Crano	Killed	II-Q
131	19-May-98	Frazer, PA	Rees Weaver & Company, Inc. Employee		Killed	II-Q

***I** refers to Proffer
 II refers to Further Proffer e.g. "II-Q" refers to Further Proffer Exhibit Q

Appendix B, Section 1-2

COURT AND CASE NUMBER: Cheery Hill, NY

DATE OF OCCURRENCE: September 30, 1980

EQUIPMENT/FACILITY: Truck-mounted latticework boom crane

HAZARD: Boom collapse during disassembly

AVAILABLE HAZARD PREVENTION:

- ◆ Provide a power hinge on the boom.

SUMMARY OF OCCURRENCE: The deceased worker was struck by a section of the crane boom when preparing to knock or actually knocking out connecting pins. Two bottom pins flew out some distance from the crane. The two top pins remained, and the boom scissored downwards, killing the worker.

Appendix B, Section 1-3

COURT AND CASE NUMBER: Vernon, TX

DATE OF OCCURRENCE: June 28, 1983

EQUIPMENT/FACILITY: Latticework boom crane

HAZARD: Boom collapse during disassembly

AVAILABLE HAZARD PREVENTION:

- ◆ Provide a power hinge on the boom.

SUMMARY OF OCCURRENCE: The worker was killed during a boom collapse when the assembly pins were knocked out. Warning labels and instructional labels on proper pin removal had been painted over.



Appendix B, Section 2-1

COURT AND CASE NUMBER: 191st District Court, Potter County, TX #689113

DATE OF OCCURRENCE: June 21, 1985

DATE COMPLAINT FILED: 1989

EQUIPMENT/FACILITY: Mobile Hydraulic Crane

HAZARD: Loss of stowed jib boom

AVAILABLE HAZARD PREVENTION:

- ◆ Redesign the boom connection with an automatic latch
- ◆ Include markers to ensure that locking pins are aligned

SUMMARY OF OCCURRENCE: A stored jib broke loose from the boom and landed on a worker. It was suspected that a large pin on the bottom portion of the crane arm to hold the jib in place was not correctly positioned. The improper position caused the bottom portion of the jib to dislodge, tearing the top portion of the jib loose.

Appendix B, Section 2-2

COURT AND CASE NUMBER: US Eastern District, Southern Division, MI #88-72677

DATE OF OCCURRENCE: July 23, 1985

DATE COMPLAINT FILED: 1988

EQUIPMENT/FACILITY: Truck mounted crane

HAZARD: Loss of stowed jib boom

SUMMARY OF OCCURRENCE: The jib fell off, injuring a worker underneath it. The jib was defective because it had only one retaining pin. The injured worker was signaling the crane's boom into place when the jib section suddenly fell off the main boom housing, crushing the worker.

Appendix B, Section 2-3

COURT AND CASE NUMBER: Court of Common Pleas, Bucks County, PA

EQUIPMENT/FACILITY: 20 ton crane

HAZARD: Loss of stowed jib boom

SUMMARY OF OCCURRENCE: A rigger was injured while storing the jib underneath the boom. The mast was raised 45 degrees. It was alleged that the pin broke and the jib swung out, hitting him on the head.

Appendix B, Section 2-4

COURT AND CASE NUMBER: US District Court of South Carolina, Aiken
Division Columbia # 1 04-21943-27

DATE OF OCCURRENCE: August 22, 2001

DATE COMPLAINT FILED: August 2004

EQUIPMENT/FACILITY: crane with a swing-away lattice attachment

HAZARD: loss of stowed jib boom

SUMMARY OF OCCURRENCE: The deceased was in the process of folding the jib boom back into the stow position when it became detached. He was struck by the falling jib and killed instantly. The process to store the boom was consistent with the instructions for pin placement and appeared to have been followed exactly.

Appendix B, Section 2-5

COURT AND CASE NUMBER: Jefferson Circuit Court, Division 8, Louisville, KY
99-CI-07293

DATE OF OCCURRENCE: December 9, 1998

EQUIPMENT/FACILITY: Flatbed mounted telescoping crane

HAZARD: Loss of stowed jib boom

SUMMARY OF OCCURRENCE: The operator thought he was had installed the stow pin properly while stowing the jib. The foreman had told him to put the pin in the latch and extend the boom to set the boom onto the boom support. When he started to set the boom onto the boom support, the jib fell and struck him in the head, killing him. No harnesses were available.

NOTES: HIFI has a record of 13 similar cases.



Appendix B, Section 3(a)-1

COURT AND CASE NUMBER: Circuit Court, First Circuit of Hawaii # 60589

EQUIPMENT/FACILITY: Tower Crane

HAZARD: Counterweight failure

AVAILABLE HAZARD PREVENTION:

- ◆ Failsafe lifting design for self-loading counterweight

SUMMARY OF OCCURRENCE: The injured worker was struck by a falling counterweight which was improperly designed and failed.

NOTES: The tower crane manufacturer should have had specific design specs for the design of concrete counterweights.

Appendix B, Section 3(a) 2

COURT AND CASE NUMBER: 136th Judicial District, Jefferson County, TX #D-109-669

DATE OF OCCURRENCE: March 1978

EQUIPMENT/FACILITY: 150 ton mobile crane

HAZARD: Counterweight failure

AVAILABLE HAZARD PREVENTION:

- ◆ Failsafe lifting design for self-loading counterweight

SUMMARY OF OCCURRENCE: A worker lost both legs at his groin when a counterweight fell on him. The crane was designed with self-loading counterweights that could only be lifted when on its carrying trailer. The counterweight had been placed on the ground so the trailer could leave the job site.

Appendix B, Section 3(b) 1

COURT AND CASE NUMBER: US Court of Appeals, 4th Circuit, South Carolina
at Columbia # 80-1388

DATE OF OCCURRENCE: 1971

EQUIPMENT/FACILITY: Truck-mounted crane

HAZARD: Pinchpoint from counterweights

AVAILABLE HAZARD PREVENTION:

- ◆ Alternate safer design that does not create a pinchpoint between the counterweight and the crane's truck bed

SUMMARY OF OCCURRENCE: A crane operator was helping a crew move a truck-mounted crane. Barriers were taken down. He got on the far side and was struck by the moving counterweight. He was crushed to death.

Appendix B, Section 3(b)-2

COURT AND CASE NUMBER: Superior Court of New Jersey, Law Division,
Atlantic County, ATL-L-193-98

DATE OF OCCURRENCE: August 19, 1996

DATE COMPLAINT FILED:

EQUIPMENT/FACILITY: Crane

HAZARD: Pinchpoint created by counterweight

AVAILABLE HAZARD PREVENTION:

- ◆ Alternate safer design that does not create a pinchpoint between the counterweight and the crane's truck bed

SUMMARY OF OCCURRENCE: When returning the hydraulic oil cap, the worker was caught by the scissor effect of the counterweight and the top of the hydraulic oil tank. His injuries included: lost spleen, 3 feet of small intestine, a liver severed in half.



Appendix B, Section 4-1

COURT AND CASE NUMBER: Superior Court, Maricopa County AZ C270075

DATE COMPLAINT FILED: March 18, 1979

EQUIPMENT/FACILITY: Bridge Crane

HAZARD: Blind zone/ vision compromise

AVAILABLE HAZARD PREVENTION:

- ◆ Movement alarms, wheel guards, better mirrors
- ◆ Closed circuit TV

SUMMARY OF OCCURRENCE: A copper smelter laborer lost a leg and an arm when he was struck by a moving bridge crane. He was then thrown into an acid filled trench next to a gantry train track. The operator could not see the laborer below, and the laborer had no warning of crane movement. It was alleged that the manufacturer failed to provide an automatic travel alarm, cow-catcher (guard), or buzzer system on the crane leg to alert the crane operator to the laborer's presence.

Appendix B, Section 4-2

COURT AND CASE NUMBER: US District Court, District of MA #90-13096-N

DATE OF OCCURRENCE: December 29, 1987

DATE COMPLAINT FILED: 1990

EQUIPMENT/FACILITY: Bridge crane

HAZARD: Pinchpoint

AVAILABLE HAZARD PREVENTION:

- ◆ Railsweeps or cowcatcher (guards), lockout system

SUMMARY OF OCCURRENCE: A 32-year old worker lost a hand when it was caught in a pinchpoint by a bridge crane that did not have any rail sweeps, guard on trolley travel, or lockout system

Appendix B, Section 4-3

COURT AND CASE NUMBER: Circuit Court of Oakland County, MI #86-319-384-NP

DATE OF OCCURRENCE: August 30, 1985

DATE COMPLAINT FILED: 1986

EQUIPMENT/FACILITY: Bridge rail end stop (RR bridge crane) with two bolts to limit trolley travel

HAZARD: Falling object

AVAILABLE HAZARD PREVENTION:

- ◆ Bridge rail end stop with two bolts to limit trolley travel

SUMMARY OF OCCURRENCE: A worker was crushed by a third-tier assembly and hoist when it fell from the second tier, from which it was suspended, due to an inadequate one-bolt stop. The worker died from his injuries. It was alleged that a two-bolt stop was required.

Appendix B, Section 4-4

COURT AND CASE NUMBER: Eastern District, Northern Division MI #84-CV-9260 BC

DATE OF OCCURRENCE: June 1981

DATE COMPLAINT FILED: 1984

EQUIPMENT/FACILITY: Overhead bridge crane

HAZARD: Vision Compromise/ Blind zone

AVAILABLE HAZARD PREVENTION:

- ◆ Better mirrors
- ◆ A travel alarm signal
- ◆ Increased clearance
- ◆ A lockout system

SUMMARY OF OCCURRENCE: An electrician was crushed between a vertical roof support post and a passing overhead crane while working on elevated rails. He died of his injuries.

Appendix B, Section 4-5

COURT AND CASE NUMBER: Maricopa County, AZ # C315922

DATE OF OCCURRENCE: August 12, 1974

EQUIPMENT/FACILITY: Bridge crane

HAZARD: Powerline Contact/ No Safe Access

AVAILABLE HAZARD PREVENTION:

- ◆ Safe access for maintenance between crane rails
- ◆ Guarded electrical conductors

SUMMARY OF OCCURRENCE: A glass installer was electrically burned and fell when walking on the bridge crane rail en route from one bridge crane to another. Hazards included an alleged unsafe access route and unguarded live ele

Appendix B, Section 4-6

COURT AND CASE NUMBER: 3rd Judicial circuit

DATE OF OCCURRENCE: April 3, 1981

DATE COMPLAINT FILED: 1981

EQUIPMENT/FACILITY: Overhead bridge crane and trolleys in steel mill

HAZARD: Inadvertent control activation/control confusion

AVAILABLE HAZARD PREVENTION:

- ◆ Better designed controls

SUMMARY OF OCCURRENCE: An electrician got his hips crushed in a pinchpoint between the drive motor and the suspended trolley.



Appendix B, Section 5-1

COURT AND CASE NUMBER: US District, Middle District, Louisiana #89-406

DATE OF OCCURRENCE: April 24, 1988

DATE COMPLAINT FILED: 1988

EQUIPMENT/FACILITY: 308-ton self-erecting tower crane

HAZARD: Boom disassembly

AVAILABLE HAZARD PREVENTION:

- ◆ Better disassembly procedure
- ◆ Certification for a trained operator

SUMMARY OF OCCURRENCE: The injured worker's face was crushed when the boom collapsed while being folded into the travel mode. The pins had been prematurely removed. This self-erecting tower crane did not have written instructions in English. The only time assembly instruction was provided was when the crane was delivered.

NOTES: The development of mobile self-erecting tower cranes began in the mid 1980s in Europe, where tower cranes are the crane of choice for building erection. A mobile self-erecting crane has distinct time-saving advantages over conventional fixed tower cranes. To be efficient requires design that ensures for an automatic rising and lowering under the supervision of someone trained as competent by the manufacturer.



Appendix B, Section 6-1

COURT AND CASE NUMBER: Circuit Court of Franklin County, State of Missouri # 04AB-CC00055 Division II

DATE OF OCCURRENCE: May 6, 1999

DATE COMPLAINT FILED: February 3, 2004

EQUIPMENT/FACILITY: Crane

HAZARD: Killer Hook

AVAILABLE HAZARD PREVENTION:

- ◆ Safety swing/swivel hook

SUMMARY OF OCCURRENCE: A worker lost his right leg when the D Ring on the lifting chain momentarily disengaged from the hook and lost control of the beam being lifted, causing it to tip. The hook, with a sheet-metal latch, can allow the D Rings to slip past.

Appendix B, Section 6-2

COURT AND CASE NUMBER: US District Court, Western District of Washington
at Tacoma

DATE OF OCCURRENCE: May 28, 2007

EQUIPMENT/FACILITY: Crane with strap hooks

HAZARD: Killer Hook

AVAILABLE HAZARD PREVENTION:

- ◆ Strong safety latch for hook

SUMMARY OF OCCURRENCE: The victim was struck by a falling fish tote basket. The lifting hook had not safety latch and that the strap fell out of the lifting hook and caused the tote to fall.

Appendix B, Section 6-3

COURT AND CASE NUMBER: Court of Common Pleas, First Judicial District of
PA No. 2542

DATE OF OCCURRENCE: April 20, 1991

EQUIPMENT/FACILITY: Digger Derrick

HAZARD: Killer hook

AVAILABLE HAZARD PREVENTION:

- ◆ Safety latch

SUMMARY OF OCCURRENCE: A worker suffered devastating personal injuries while operating a digger derrick. The sling holding a utility pole came out of an open-throated hook and the falling pole struck the worker on the head.

Appendix B, Section 6-4

COURT AND CASE NUMBER: Unkonwn

DATE OF OCCURRENCE: June 23, 1980

EQUIPMENT/FACILITY: Bridge Crane

HAZARD: Killer hook, vision compromise

AVAILABLE HAZARD PREVENTION:

- ◆ Hook with safety latch
- ◆ Bridge crane travel alarm

SUMMARY OF OCCURRENCE: A worker was killed when struck by the falling load from a bridge crane. The hook disengaged during a collision with another bridge crane. Neither bridge crane saw the other. The hook should not have disengaged upon impact.



Appendix B, Section 7

COURT AND CASE NUMBER: Oklahoma City, OK

DATE OF OCCURRENCE: January 12, 1991

EQUIPMENT/FACILITY: Crane

HAZARD: Two-blocking

AVAILABLE HAZARD PREVENTION:

- ◆ Anti two-blocking device

SUMMARY OF OCCURRENCE: A worker broke his feet and ribs when working in a manlift suspended from the crane when the crane two-blocked. The load line broke, dropping the basket 19 feet.



Appendix B, Section 8-1

COURT AND CASE NUMBER: 11th Judicial Circuit, Dade County, FL #83-3514

DATE OF OCCURRENCE: October 21, 1981

DATE COMPLAINT FILED: 1983

EQUIPMENT/FACILITY: Crane

HAZARD: Pinchpoint by carrier frame

AVAILABLE HAZARD PREVENTION:

- ◆ Increase space between rotating cab and carrier frame

SUMMARY OF OCCURRENCE: The operator was crushed when he was caught in the back of the crane superstructure as it was turning in its tracks.

Appendix B, Section 8-2

COURT AND CASE NUMBER: Minneapolis, MN

DATE OF OCCURRENCE: January 15, 1984

DATE COMPLAINT FILED: 1985

EQUIPMENT/FACILITY: Truck crane

HAZARD: Pinchpoint by carrier frame

AVAILABLE HAZARD PREVENTION:

- ◆ Increase space between rotating cab and carrier frame

SUMMARY OF OCCURRENCE: An injured oiler was found bent over the carrier frame top and standing on the shelf created by the carrier frame. He had been crushed in the pinchpoint created by the rotating cab/counterweight and the carrier frame.



APPENDIX C: Litigated Cases of Aerial Lift Hazards

Appendix C, Section 1(a)

COURT AND CASE NUMBER: 319th Judicial District, Nueces County, TX #84-7397-G

DATE COMPLAINT FILED: 1984

EQUIPMENT/FACILITY: Scissor lift

HAZARD: Upset

AVAILABLE HAZARD PREVENTION:

- ◆ Even, hole free work surface
- ◆ Outriggers extended

SUMMARY OF OCCURRENCE: An electrician broke his hip when a scissor lift that was extended 15 feet off the ground upset. The wheel of the lift fell into one of several 4 ft by 8 in holes. Outriggers were not extended.

Appendix C, Section 1(b)

COURT AND CASE NUMBER: 11th Judicial Circuit, Dade County FL #224243

DATE OF OCCURRENCE: January 22, 1989

DATE COMPLAINT FILED: January 1990

EQUIPMENT/FACILITY: Scissor lift

HAZARD: Upset

AVAILABLE HAZARD PREVENTION:

- ◆ Automatic outriggers
- ◆ Interlock to prevent lifting until outriggers are in place

SUMMARY OF OCCURRENCE: A worker was brain damaged when the personnel lift he was on upset from the wind.

Appendix C, Section 1(c)

COURT AND CASE NUMBER: Superior Court, 3rd Judicial District, Anchorage,
AK 3AN-91-2875

DATE OF OCCURRENCE: April 12, 1989

DATE COMPLAINT FILED: 1991

EQUIPMENT/FACILITY: Scissor lift

HAZARD: Upset during transport

AVAILABLE HAZARD PREVENTION:

- ◆ Warning system
- ◆ Better designed trailer
- ◆ ROPS/FOPS

SUMMARY OF OCCURRENCE: A worker's leg was injured during the loading of a scissor lift onto a trailer used by the Anchorage school district. The trailer was on a slight incline and the ramp was not square. The worker was backing the scissor lift up onto the trailer and the lift tipped over onto his legs.

Appendix C, Section 1(d)

COURT AND CASE NUMBER: Unknown

DATE OF OCCURRENCE: December 13, 1976

EQUIPMENT/FACILITY: Scissor lift

HAZARD: Inadvertent activation of controls

AVAILABLE HAZARD PREVENTION:

- ◆ Dust-proof controls

SUMMARY OF OCCURRENCE: The lift operator was crushed by lift actions caused by contamination of controls. The functionality of the control system was compromised by dust inherent to the plant in which he was working. Had the control and switching system been dust-proof the machine would have functioned as instructed.



Bibliography

1. Bishop, Phil, "Defining Self-Erectors" *Lift and Access*, March 2007
2. MacCollum, David, "Critical Hazard Analysis of Crane Design" *Professional Safety*, January 1980
3. Mongeluzzi, Robert J. & Morgan, Derald J. "Do Insulated Links Help?" *Lift Equipment*: Mongeluzzi, Plaintiff's attorney, Yes; Morgan, defense witness, No; Feb-March, 1991
4. MacCollum, David, "Crane Design Hazards Analysis" *Automotive Engineering and Litigation*, 1984
5. MacCollum, David, Chapter 13, OSHA Instructions, Cranes and Derricks, 1990
6. MacCollum, David, "Guide to Crane Safety," North Carolina Division of Occupational Safety, 1990
7. MacCollum, David, "Equipment Powerline Contacts," *Hazard Information Newsletter*, Volume 1, Issue 4m July 1996.
8. MacCollum, David, *Crane Hazards and Their Prevention*, (Book) American Society of Safety Engineers, 1993
9. MacCollum, David, "Safety Interventions to Control Hazards Related to Powerline Contacts by Mobile Cranes and Other Boomed Equipment,"

Research Report conducted by the Hazard Information Foundation, Inc. for the Center to Protect Workers' Rights, 2004.

10. Peters, George A. and Barbara J. *Human Error: Causes and Control*, Taylor and Francis, CRC Press, 2006.

11. Stout NIOSH alert "Prevention Worker Injuries and Deaths from Mobile Crane Tip Over, Boom Collapse, and Uncontrolled Hoisted Loads" 2006. (This reference relies on information from (5) above: MacCollum, David "Guide to Crane Safety," North Carolina Division of Occupational Safety, 1990.

"Today's Equipment has too many Shades of Gray," *Engineering News Record*, July 3, 2006



Section entitled "Other Crane Hazards" and is several bullets down. The text is in the bullet that begins, "Self-raising mobile tower crane systems are often hazardous and require following a very complicated procedure."

This lack of distinction has caused confusion and stifled the use of self-erecting tower cranes in California. A tower crane collapse in San Francisco that killed five people and injured 21, following two tower crane collapses in 1981 and 1985 in Los Angeles, sparked statewide regulations that now require a permitting process to erect a "tower crane."