



# Inspecting Occupational Safety and Health in the Construction Industry

Luis Alves Dias



# Inspecting Occupational Safety and Health in the Construction Industry

Luis Alves Dias

Prepared for the International Labour Office  
International Training Centre - Turin, Italy



Copyright © International Training Centre of the International Labour Organization 2009

Publications of the International Training Centre of the ILO enjoy copyright under Protocol 2 of the Universal Copyright Convention. Applications for authorization to reproduce, translate or adapt part or all of its contents should be addressed to the International Training Centre of the ILO. The Centre welcomes such applications. Nevertheless, short excerpts may be reproduced without authorization, on condition that the source is indicated.

---

INSPECTING OCCUPATIONAL SAFETY AND HEALTH IN THE CONSTRUCTION INDUSTRY

ISBN 978-92-9049-489-8

First edition 2009

The designations employed in publications of the International Training Centre of the ILO, which are in conformity with United Nations practice, and the presentation of material therein do not imply the expression of any opinion whatsoever on the part of the Centre concerning i.a. the legal status of any country, area or territory or of its authorities, or concerning the delimitation of its frontiers. The responsibility for opinions expressed in signed articles, studies and other contributions rests solely with their authors, and publication does not constitute an endorsement by the Centre of the opinions expressed in them.

Publications of the Centre, as well as a catalogue or list of new publications, can be obtained from the following address:

Publications, International Training Centre of the ILO

Viale Maestri del Lavoro, 10 - 10127 Turin, Italy

Telephone: +39 - 011 - 6936693

Fax: +39 - 011 - 6936352

E-mail: [Publications@itcilo.org](mailto:Publications@itcilo.org)

Printed by the International Training Centre of the ILO, Turin, Italy

## Foreword

The construction industry is one of the most dangerous sectors. The incidence of fatalities, injuries and illnesses to construction workers are among the highest in most of the countries. With a view to preventing accidents and diseases among workers in the construction industry, in 1988 the International Labour Organization (ILO) adopted the Safety and Health in Construction Convention (No. 167), and Recommendation (No. 175).

As like other ILO conventions and standards on occupational safety and health (OSH), these instruments are essential points of reference to develop national standards, to set forth the principles, tripartitely agreed, that should govern the OSH in the construction industry at both the national level and to provide guidelines to the construction enterprises. To support the practical implementation of the standards, in 1992 the ILO published the code of practice, Safety and Health in Construction, containing technical guidance, recommendations and know-how for all those who have responsibility for OSH within the construction sector. The ILO has worked in numerous countries to carry out its programme of promoting the implementation of these standards. However, laws are only as good as their enforcement.

A system for the supervision of the implementation of the labour standards into the workplaces is also necessary. The inspection of OSH in the construction industry has many common issues with the OSH inspection in other industries, but there are also many specific sectoral issues. This handbook “Inspecting occupational safety and health in the construction industry” deals with these specific issues on OSH in the construction industry as a tool for information and training for the inspectors.

It has been specially designed for the managers of the labour inspectorates and for the field inspectors. It seeks to inform them on key concepts and OSH issues of the construction industry as well as to upgrade some specific competences that they both will require in order to fulfil their functions: mainly managing an OSH inspection programme in the construction sector in the case of the managers, and performing on-site OSH inspection visits in the case of field inspectors.

In addition to the managers in labour inspectorates and field inspectors, this handbook may also be of interest to other people involved in the construction industry. These could include trainers and advisers on OSH issues belonging to government, employers’ and workers’ organizations, professional or industrial bodies, training institutions as well as the internal staff of enterprises of the construction sector, managers, OSH specialists, supervisors or workers.

This document was elaborated for the International Training Centre of the ILO by Mr. Luis Alves Dias, Professor of the Department of Civil Engineering and Architecture of Instituto Superior Técnico - Technical University of Lisbon and an international OSH expert in construction. We thank Mr. Luis Alves Dias for the preparation of this handbook and the Government of Italy for the financial support which made this publication possible.

Mr. Félix Martín,  
Senior Programme officer,  
Social Protection Programme,  
International Training Centre of the ILO



# Table of Contents

<b>1. Introduction</b> .....	<b>1</b>
<b>2. Key OSH and construction concepts</b> .....	<b>3</b>
2.1 Key OSH concepts .....	3
2.2 Key construction concepts .....	5
<b>3. The construction industry and OSH</b> .....	<b>10</b>
3.1 Characterization of the construction industry .....	10
3.2 Main features of the construction industry and its specific OSH features .....	12
3.3 Strategies for improving OSH in the construction industry .....	14
<b>4. Selection of construction enterprises and sites for inspection</b> .....	<b>21</b>
4.1 Prior Notice of a construction project .....	22
4.2 Method for selecting construction sites to be inspected .....	24
4.3 Method for selecting construction enterprises to be inspected .....	28
4.4 Procedure to establishing the relative weights .....	31
<b>5. Planning, monitoring and evaluation of an OSH inspection programme</b> .....	<b>33</b>
5.1 Planning an OSH inspection programme .....	33
5.2 Monitoring and evaluation of an OSH inspection programme .....	35
<b>6. OSH organization of the construction enterprises and sites, including management of subcontractors</b> .....	<b>37</b>
6.1 OSH organisation of construction enterprises and sites .....	37
6.2 Management of subcontractors .....	38
<b>7. OSH hazards/risks on construction sites</b> .....	<b>43</b>
7.1 General principles of prevention .....	43
7.2 The main OSH hazards/risks in the construction industry .....	46
<b>8. OSH control measures on construction sites</b> .....	<b>49</b>
8.1 OSH control measures related to the basic resources .....	50
8.2 OSH control measures related to construction operations and/or elements .....	55
8.3 OSH control measures related to construction sites .....	65
<b>9. Instruments and methodology for inspection visits</b> .....	<b>70</b>
9.1 Instruments for inspection visits .....	70
9.2 Methodology for the inspection of construction sites .....	79
<b>10. Summary and conclusions</b> .....	<b>87</b>
<b>References</b> .....	<b>89</b>

## Annexes

Description	Nr. Pages
a) Example of an Inspection Plan for construction sites	4
b) Example of a checklist to inspect construction sites	12
c) ILO Convention C167 on Safety and Health in Construction, 1988	10
d) Recommendation R175 on Safety and Health in Construction, 1988	6





## Index of Figures

Figure 1	Example of a risk scale (likelihood x severity) .....	4
Figure 2	Construction project, construction work and construction job concepts.....	6
Figure 3	Organization chart of those involved in a construction project (execution phase).....	7
Figure 4	Construction Management Systems/Models.....	9
Figure 5	Distribution of the fatal accidents in the construction industry.....	11
Figure 6	Accidents in the construction industry versus all industries .....	11
Figure 7	The main elements/objectives to take into account in a construction project.....	12
Figure 8	Prevention costs versus occupational accidents costs .....	13
Figure 9	The main general provisions of the ILO Convention 167 .....	16
Figure 10	Causes of fatal occupational accidents in construction.....	17
Figure 11	The European Union approach (Directive 92/57/EEC) .....	19
Figure 12	A possible strategy for promoting and improving OSH in the construction industry .....	19
Figure 13	Example of the distribution of two-monthly inspections .....	33
Figure 14	Control and evaluation of an OSH inspection program .....	35
Figure 15	Some facts on subcontracting in the construction industry .....	38
Figure 16	Subcontracting: limited and controlled.....	39
Figure 17	Control of subcontractors and subcontracting chain .....	40
Figure 18	Flow chart of the subcontracting chain .....	41
Figure 19	Form for controlling of the insurance covering the occupational accidents.....	42
Figure 20	Most frequent hazards/risks in the construction industry .....	46
Figure 21	The management of construction projects and their resources .....	49
Figure 22	Form for recording the distribution of PPE and information on hazards/risks .....	52
Figure 23	Form for monitoring materials and permanent equipment.....	53
Figure 24	Form for monitoring the support equipment and accessories .....	53
Figure 25	Form for monitoring construction operations/elements .....	55
Figure 26	Example of a MPP of a construction operation/element.....	56
Figure 27	Classes of temporary guardrails (EN 13374:2004).....	58
Figure 28	Technical characteristics/specifications for temporary guardrails (EN 13374:2004).....	58
Figure 29	Classification of a working scaffold.....	60
Figure 30	Width, Headroom and stair classes of a scaffold.....	60
Figure 31	Service load classes of a scaffold and their application .....	61
Figure 32	Classification of temporary safety nets .....	62
Figure 33	Systems of temporary safety nets .....	62
Figure 34	Classes of temporary safety nets .....	63
Figure 35	Maximum fall height and minimum catching width of safety nets .....	63
Figure 36	Maximum deformation of temporary safety nets and clear height under it.....	64
Figure 37	Form for recording the non conformance/compliance and corrective/ preventive actions .....	66
Figure 38	Occupational safety and health monitoring.....	67
Figure 39	Occupational accident statistics .....	68
Figure 40	Enforcement instruments .....	71
Figure 41	Results of the inspection of 25000 construction sites in the EU (SLIC, 2005) .....	71
Figure 42	Groups of non compliances .....	72
Figure 43	Form for a safety and health plan for very small construction projects .....	76
Figure 44	Main steps of the inspection process of a construction site.....	80
Figure 45	The proposed rating system.....	83



## Index of Tables

Table 1:	Content of the Prior Notice.....	23
Table 2:	Possible criteria for the selection of construction sites (1st Level) .....	24
Table 3:	Possible criteria for the selection of construction sites (2nd Level) .....	25
Table 4:	Possible criteria for the selection of construction enterprises (1st Level).....	29
Table 5:	Possible criteria for the selection of construction enterprises (2nd Level) .....	29
Table 6:	Example of the definition of relative weights of the criteria and sub-criteria.....	32
Table 7:	Classification of construction enterprises by the number of workers employed.....	37
Table 8:	The nine General Principles of Prevention .....	44
Table 9:	Identification of hazards and risks of a construction project/site.....	47
Table 10:	Examples of Personal Protective Equipment .....	51
Table 11:	Examples of measures to prevent some of the main hazards/risks in construction.....	57
Table 12:	Possible use of the enforcement instruments in view of the non-compliances.....	73
Table 13:	Example of a possible structure and contents for the SHP.....	75
Table 14:	Example of structure and contents for the SHF for a building .....	78
Table 15:	Summary checklist for the evaluation of a construction site (first level).....	85
Table 16:	Detailed checklist of the evaluation of a working scaffold (second level) .....	86

# Introduction

The global estimates of occupational accidents published by the International Labour Organization (ILO), based on world figures for all economic activities in 2001, are about 350 000 fatal accidents and 270 million non-fatal accidents (those causing more than 3 days' absence) every year.

In the construction industry, the ILO estimates that there are about 60 000 fatal occupational accidents (about 17% of the total) a year [Valcárcel, 2003], although the industry accounts for only 5 to 10% of all employment (there are estimated to be about 110 million construction workers in the world). The global figures suggest that the construction industry may also have more than 45 million non-fatal accidents. This means that in the construction industry there is about one fatal accident every 10 minutes and more than one non-fatal accident per second.

These figures are unacceptable from both the social and the human point of view. Although much has been done, and continues to be done, around the world to improve working conditions and prevention measures, there is still much to do in terms of an occupational safety and health (OSH) policy aimed at “zero accidents” and “zero disease” in the construction industry.

The recognition that the construction industry is a highly hazardous industry cannot justify its poor OSH record. In fact, the management of OSH risks and compliance with OSH laws in the construction industry are but two of the main issues that need more attention.

Those involved in the construction industry know the construction processes. They select the most appropriate one for each case, taking into account productivity and, in more and more cases, OSH. In fact, construction professionals, in general, know the hazards involved in each construction process and they also know the prevention measures to take. In spite of this, occupational accidents and diseases continue to happen, and so there is a failure in the management of OSH risks.

Compliance with OSH laws is very poor in many countries. The explanations for this are many, including the high number of existing laws and regulations on OSH to be obeyed (sometimes wide-ranging and very prescriptive, making it hard to apply them), and all the technical standards, specifications and codes of practice related to the construction industry.

Moreover, monitoring compliance with these laws and regulations is sometimes overlooked by enterprises (internal control) and by labour inspectorates (external control) for reasons including limited human resources (not enough well qualified safety experts and inspectors in proportion to the high number of enterprises and sites and their range of economic activities).

While enterprises have a duty to equip themselves with all the resources needed to perform their jobs in a safe and healthy workplace, labour inspectorates cannot have an inspector on each construction site to force compliance with the laws and regulations. Accordingly, there is a need to prioritize OSH inspections of construction enterprises and sites.

This document aims to contribute to an effective OSH inspection in the construction sector. It aims to help labour inspectorates to achieve two main objectives: (i) managing an OSH inspection programme; and (ii) performing on-site OSH inspections in the construction sector. For this purpose, a knowledge of key construction concepts and of the construction industry is of the utmost importance. They are covered in Sections 2 (Key OSH and construction concepts) and 3 (The construction industry and OSH). They may be of interest for both the managers of the labour inspectorates and labour inspectors themselves.



The first objective (managing an OSH inspection programme) is mainly for managers in labour inspectorates who have to prepare and manage the internal procedures for the selection, monitoring and evaluation of an effective OSH inspection programme and for on-site OSH inspections by the labour inspectors. Sections 4 (Selection of construction enterprises and sites for inspection) and 5 (Planning, monitoring and evaluation of an OSH inspection program) should be of special interest to managers in labour inspectorates.

The second objective (performing on-site OSH inspections) is for labour inspectors who make on-site inspections of construction enterprises and sites. Sections 6 (OSH organization of the construction enterprises and sites, including management of subcontractors), 7 (OSH hazards/risks on construction sites), 8 (OSH control measures on construction sites) and 9 (Instruments and methodology for inspection visits) should be of special interest to labour inspectors.

# Key OSH and construction concepts

Understanding and using the main OSH and construction terms and concepts will facilitate proper communication among all those involved in the construction process.

Although many of the terms have been defined in different documents, some terms are sometimes used with different meanings, and different terms are sometimes used with the same meaning.

To avoid misunderstandings, we set out below some of the key terms used in both areas and define them as they will be used in this document.

They are organized, as far as possible, into “pairs” of similar terms and definitions.

## 2.1 Key OSH concepts

The main terms and concepts related to OSH used here come from laws, regulations, standards, guidelines, specifications and other documents. The most important ones are defined below, including some notes.

**Incident** (ILO-OSH 2001): An unsafe occurrence arising out of or in the course of work where no personal injury is caused.

**Accident**: The same than an incident, but where the unsafe occurrence causes a personal injury.

**Note**: The terms “incident” and “accident” do have a broader definition, but here they refer to occupational safety and health. For the specific purposes of national law, these definitions may vary from country to country.

**Competent person** (ILO-OSH 2001): A person with suitable training, and sufficient knowledge, experience and skill, for the performance of the specific work.

**Note**: This concept refers to a physical person. A “competent legal person” should include one or more “competent physical persons” besides other requirements usually defined by law.

**Document** (ANSI Z10): Written, electronic, or photographic information such as a procedure or record.

**Audit** (ILO-OSH 2001): A systematic, independent and documented process for obtaining evidence and evaluating it objectively to determine the extent to which defined criteria are fulfilled. This does not necessarily mean an independent external audit (an auditor or auditors from outside the organization).

**Inspection**: Similar to an audit, but focusing on a single item or process and based usually on “yes/no” answers, whereas audits are more detailed and look at the entire process in depth.

**Note**: Audits may also review all elements that can influence each of the processes under consideration. They may go beyond “yes/no” answers, e.g. to determine how far an item or process complies with a reference document (law, internal specification, standard, etc.) and how it can improve. An audit may involve many specific inspections. Where these inspections cover all the single processes of a chain of a broad process, then it may work like an audit.



**Hazard** (ILO-OSH 2001): The inherent potential to cause injury or damage to people's health.

**Risk** (ILO-OSH 2001): A combination of the likelihood of an occurrence of a hazardous event and the severity of injury or damage to the health of people caused by this event.

**Note:** Different scales may be used to determine the risk level (RL) of any construction process, depending on the classification of the likelihood (Lk) and of the severity (Sv) to be considered. In this document a scale of 1 to 5 (Figure 1) is used for both likelihood and severity (very low, low, medium, high and very high) and the risk level is calculated using the following formula:

Risk Level (RL) = Likelihood (1 ≤ Lk ≤ 5) x Severity (1 ≤ Sv ≤ 5)

The result may be grouped into five risk level intervals: RL < 5 (Very Low), 5 ≤ RL < 10 (Low), 10 ≤ RL < 15 (Medium), 15 ≤ RL < 20 (High) and 20 ≤ RL < 25 (very high)

Severity	Very High	5	10	15	20	25
	High	4	8	12	16	20
	Medium	3	6	9	12	15
	Low	2	4	6	8	10
	Very Low	1	2	3	4	5
		Very Low	Low	Medium	High	Very High
		Likelihood				

Figure 1 – Example of a risk scale (likelihood x severity)

**Hazard assessment** (ILO-OSH 2001): A systematic evaluation of hazards.

**Risk assessment** (ILO-OSH 2001): The process of evaluating the risks to safety and health arising from hazards at work.

**Note:** In this document, whereas “assessment” is taken as subjective, “evaluation” is quantitative.

**Active monitoring** (ILO-OSH 2001): the ongoing activities which check that hazard and risk preventive and protective measures, as well as the arrangements to implement the OSH management system, conform to defined criteria.

**Reactive monitoring** (ILO-OSH 2001): Checks that failures in the hazard and risk prevention and protection control measures, and the OSH management system, as demonstrated by the occurrence of injuries, ill health, diseases and incidents, are identified and acted upon.

**Note:** In this document, more emphasis is given to the active monitoring rather than to the reactive monitoring. A proactive approach for OSH should take priority over the reactive approach.

**Compliance** (ANSI Z10): Meeting the requirements of local, state or federal statutes, standards or regulations.

**Conformance** (ANSI Z10): Meeting the requirements of the organization's OHS-MS and this standard.

**Note:** Whereas “compliance” refers to compulsory requirements, “conformance” refers to voluntary requirements.

## 2.2 Key construction concepts

A construction project usually involves many parties. The main ones are the owner (client), the designer and the constructor. Each of these may involve other further parts (subcontractors, workers, etc.) and be organised in various forms. They may be a physical or legal person, public or private. Other interested parties may include financial bodies, insurance companies, end-users, supervisors, official inspectors, quality controllers and safety experts.

The development of a construction project draws on many concepts during its life cycle and these should be clarified in relation to the parties. The specific OSH duties of each of them should be set out clearly.

Some of the most frequently used terms in a construction project shall be clarified, bearing in mind that, sometimes, different meanings are assigned to the same terms for reasons such as the legislation applicable to the construction industry in a specific country. Different meanings in different languages have also caused misunderstandings among construction experts from different countries.

**Construction** (ILO Convention C167): this term covers: (i) building, including excavation and the construction, structural alteration, renovation, repair, maintenance (including cleaning and painting) and demolition of all types of buildings or structures; (ii) civil engineering, including excavation and the construction, structural alteration, repair, maintenance and demolition of, for example, airports, docks, harbours, inland waterways, dams, river and avalanche and sea defence works, roads and highways, railways, bridges, tunnels, viaducts and works related to the provision of services such as communications, drainage, sewerage, water and energy supplies; (iii) the erection and dismantling of prefabricated buildings and structures, as well as the manufacturing of prefabricated elements on the construction site.

**Construction site** (ILO Convention C167): any site at which any of the processes or operations of a construction (as defined above) are carried on.

**Workplace** (ILO Convention C167): means all places where workers need to be or to go by reason of their work and which are under the control of an employer.

**Note:** In some countries, a construction site may also be any place where the construction works (as defined below) are carried on, including the places (temporary or mobile) where support activities are carried on.

**Construction work:** any work for the physical realization, partial or whole, of a new facility (e.g. a building, a bridge, a road, etc.), as well as rehabilitation, adaptation or any other work on an existing facility where it has by law to be carried out by a competent (qualified/certified) person; where the construction work is to be carried out in parts (e.g. the structure, the water system, the electrical system, etc.) and each part is done under a different contract, simultaneously or successively, these parts are usually called a construction job (Figure 2).

**Note:** A construction work may also be defined as an unique process, consisting of a set of coordinated and controlled activities with start and finish dates, undertaken to achieve an objective conforming to specific requirements, including the constraints of available resources (adapted from the ISO 9000:2005 on the fundamentals and vocabulary).

**Construction project:** an investment programme to carry out one or more construction works (facilities), where the social, economic, technological and administrative issues, during the whole life cycle are taken into account (Figure 2).



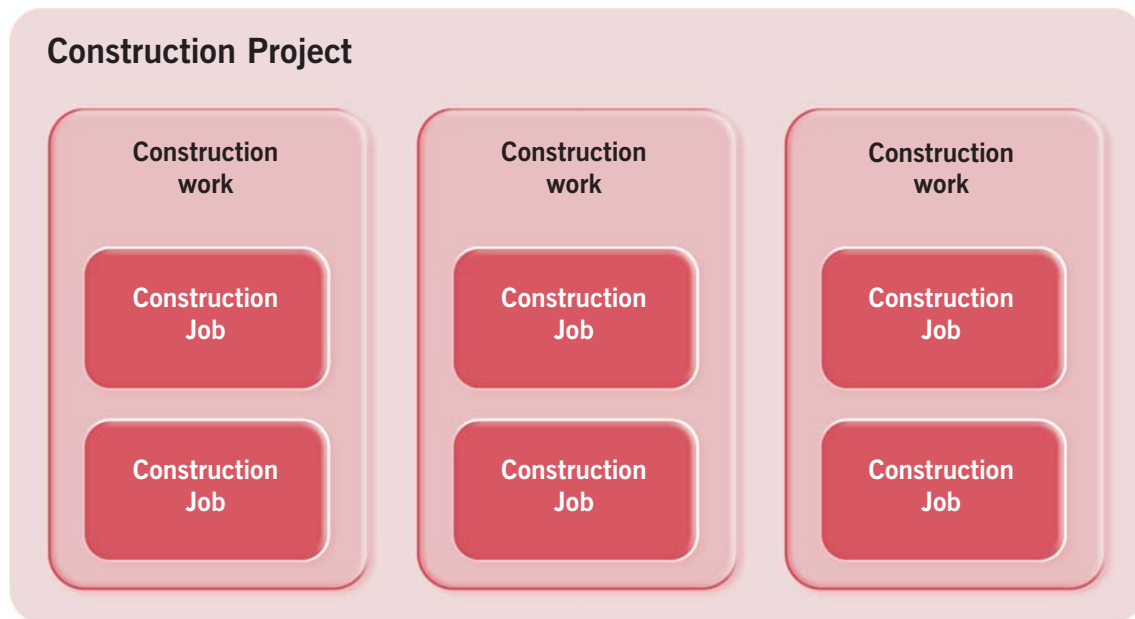

Figure 2 - Construction project, construction work and construction job concepts

**Constructor:** a competent person, physical or legal, holding official qualification/certification under national law to undertake construction works.

Note: This official qualification/certification, usually, lists the specific works that the constructor may perform; different names are used with the same meaning such as construction company and construction enterprise.

**Contractor** (ILO-OSH 2001): a person or an organization providing services to an employer at the employer's worksite in accordance with agreed specifications, terms and conditions.

Notes: (i) in the construction industry, a contractor may also be defined as a person, physical or legal, engaged to perform a specific job or service on the basis of a fee (hourly based or task performed based); (ii) besides the constructor and sub-constructors (both are also contractors), many different contractors and/or subcontractors such as enterprises of temporary workers, enterprises supplying construction equipment with operator, self-employed workers, persons (physical or legal) rendering specific services (e.g. OSH experts) may be involved in a construction project; (iii) in many countries, the term "contractor" is used for the purpose of some laws to mean the "constructor" as defined above; (iv) in some countries, the OSH law defines "contractor" as any person (including the owner/client and the principal contractor as defined hereafter), who carries out or manages construction work.

**Principal Contractor** (adapted from the ILO Convention C167): a person, physical or legal, with actual control over or primary responsibility for overall construction site activities, who is responsible for co-ordinating the prescribed safety and health measures and for ensuring compliance with such measures. When he is not present at site he shall nominate a competent person or body at the site with the authority and means necessary to ensure on his behalf co-ordination and compliance with these measures. The principal contractor should be appointed (usually by the owner/client) whenever two or more employers undertake activities simultaneously at one construction site.

Notes: (i) The principal contractor is not necessarily the general (or main) contractor, but he may be if he is present on site; (ii) The owner/client may act as the principal contractor where there is no general contractor and if he has the knowledge, competence and means to do so under the national law.

**Employer** (ILO-OSH 2001): Any physical or legal person that employs one or more workers; the constructors, sub-constructors, contractors and subcontractors, while legal persons are also Employers.



**Notes:** (i) A construction project (execution phase) may involve one constructor (alone or in a consortium, in a joint venture or in another form for a particular project) or more than one constructor (each with a contract with the owner/client); each of these may be helped by sub-constructors and/or subcontractors to perform the construction project, including their subsequent and successive chain of sub-constructors or subcontractors (Figure 3); (ii) concerning OSH, and for monitoring purposes, it is important to distinguish between the sub-constructors (those who are qualified/certified and know the construction job, the risks involved and the prevention measures to implement) and the subcontractors that are not qualified/certified under the national law to undertake construction works; (iii) for OSH monitoring, the self-employed workers should be considered as subcontractors or as any other worker involved in the construction project, as they are involved in the construction project under the control and coordination of whoever engaged them.

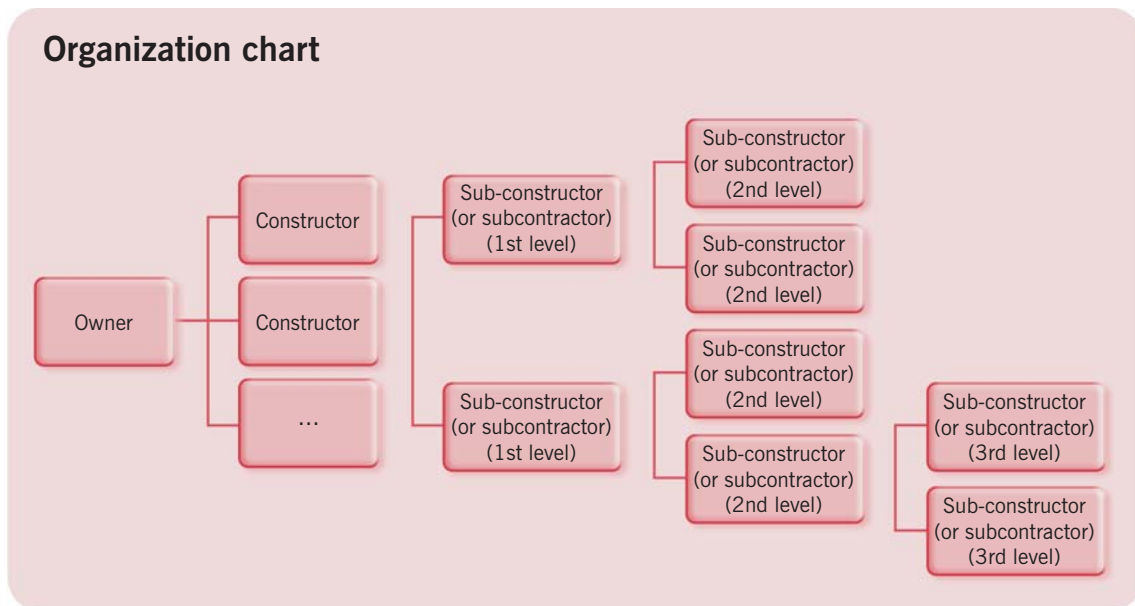

Figure 3 - Organization chart of those involved in a construction project (execution phase)

**Life cycle of a construction project:** The set of the main phases in developing a construction project, from the initial idea (identification of the need) to the end of its life (demolition or deconstruction).

**Note:** These phases may be simplified into the following three: (i) conception and design; (ii) construction/execution, and; (iii) operation/utilization. However, in many cases and depending on the purposes, there is a need to consider more detailed phases such as the following (Figure 4 below): (i) inception, strategic planning, initial studies, feasibility studies; (ii) programming, briefing, planning; (iii) engineering, design; (iv) build, construction, execution; (v) commissioning, start-up; (vi) operation, utilization/use; (vii) maintenance, rehabilitation, adaptive reuse; (viii) deconstruction, recycling, demolition. Depending on each cases, other phases are also considered at different moments during the life cycle, as is the case of “procurement” (designers, constructors, supervisors, safety and health coordinators, etc.).

**Project Management (PM):** the management, during most of the earlier phases of the life cycle, of the development of a construction project, from inception (including planning, design, procurement, where applicable, etc.) to the end of the execution phase and the commissioning/star-up and, sometimes, including also the “period of warranty” (usually, 5 to 10 years from the completion of the execution phase, largely depending on the legislation of each country). For each construction project, the scope of the PM is clarified in the contract between the parties involved (owner/client and project manager).

**Construction Management (CM):** the management during only the execution phase, and sometimes also the contractor procurement phase (it does not usually include the conception/design phase). For each construction project, the scope of the CM is clarified in the contract between the parties involved (owner and construction manager).



**Construction Management versus Project Management:** in both cases, the managers could be the owner's in-house personnel if the owner has such capabilities, but often they are external experts (individual persons or organizations who act on behalf of the owner/client). In some cases (e.g. European Union Directive 92/57/EEC on safety and health in construction), these managers are also called "project supervisors" and are responsible for supervising the design and/or the execution of the project. When their responsibilities are restricted to the design phase, they are usually called "project supervisors for the design phase/stage" and when their responsibilities are restricted to the execution phase they are usually called "project supervisors for the execution (or construction) phase/stage". In a CM approach, the construction manager, acting on behalf of the owner/client, has the primary duty of overseeing (and ensuring the accomplishment of) the contracts established between the owner/client and the various contractors. In many cases, they do not participate in the formulation of these contracts and have no responsibility for the quality of the design documents. They supervise the construction of the project based on the owner's requirements included in the contract with the contractors. If the requirements are not appropriate or the design documents are poor, the construction manager usually has a reduced responsibility on the quality of the final product. If this condition exists, it may be more difficult for the project execution to be successful and the objectives defined by the owner/client may also be more difficult to be achieved. On the other hand, in a PM approach the project manager will be responsible for the entire process, including design document approval and the supervision of the contract documents with the contractors. In this case, the construction project has a greater probability of being successful, depending on the commitment and the skill of the project management team, of the design team and of the contractor team (staff personnel, subcontractors, workers). In some cases, the PM approach is also complemented with a CM team under the responsibility of the project manager.

**Construction Management Systems/Models (CMS):** the various models to promote the construction project from inception (identification of the need/idea) to the end of its life. The main Construction Management Systems/Models are:

(i) "**Design-Bid-Build (DBB)**", in which the owner assigns the design and the execution of the project in two separated contracts, respectively, to a designer and to a constructor (or a group of constructors), respectively; this traditional approach is the most common model in small and medium construction projects (private and public) and sometimes also in large projects.

(ii) "**Design-Build (DB)**", in which most of the design and of the execution of the construction project is assigned to the same constructor (or a group of constructors) in a single contract. This model is based on the specifications prepared by the owner (or by another person under his responsibility), which include preliminary designs. The majority of the (detailed) design is the responsibility of the constructor, who usually assigns this task to a designer through a private subcontract. This model is used particularly in construction projects in which, for example, cost and time/schedule savings are expected as a result of technological processes and innovative methods that the constructor may use.

(iii) "**Developer-constructor**", in which the developer and constructor are the same private entity, i.e., the developer is both the owner and the constructor. The design is usually assigned to a designer through a private contract. This model is used mainly in residential construction projects.

(iv) "**Public-private partnership (PPP)**", a contractual arrangement between a public and a private entity (or group of entities), in which a much greater emphasis is put on whole life cycle performance in order to optimize cost, time, quality, environment and safety and health throughout the construction project. There are many different approaches for the PPP model, depending on who takes the responsibilities and risks during the life cycle of the project (e.g. conception, design, building, operation, maintenance and finance). This model is used mainly in very large and/or complex projects (namely infrastructures, like bridges, motorways, hospitals, etc.), involving a large number of parties (and consequently, many contracts) who share the responsibilities and risks of the project to the extent specified in the contract; some of the most common used PPP approaches follow. Note, however, that the DBB and the DB models referred to above, are also particular cases of PPP models when the owner is a public entity which keeps the main responsibilities relating to the construction project (financing, use, operation and maintenance).

**(iv.1) “Design-build-operate-maintain (DBOM)”**, also known as “build--operate--transfer (BOT)” or “turnkey”, combines the design-build (DB) model with the operation and maintenance that the owner/client assigns to another entity (or a group of entities), usually private, for a fixed number of years after the completion of the project (usually, between 5 to 20 years, sometimes even more). At the end, the project is transferred to the owner/client. In this model the owner/client is responsible for financing the project, including the operation and maintenance costs, and keeps the revenue from its operation. All the costs are included in the procurement process and so the other entity should stipulate the construction process to be used and provide a detailed maintenance plan.

**(iv.2) “Design-build-finance-operate (DBFO)”**, also known as “concession”, where designing (majority/detail design), building, operating and financing are transferred by the owner/client to another entity or group of entities (the “concessionaire”), usually private, that assumes all the responsibilities and risks specified in the contract. In this model, the financing may be supplied partially or wholly by the owner through grants and/or through the future revenue originated by the operation (e.g. tolls) for a fixed number of years after the completion of the project (usually, more than 20 years, sometimes called the “concession period”), and ending with the transfer of the project to the owner/client. Sometimes, the owner/client may transfer revenue-collecting of an existing project to the “concessionaire”, together with the responsibility for maintenance.

**(iv.3) “Design-build-own-operate (DBOO)”**, also known as just “build-own-operate (BOO)”, in which a public entity grants to a private entity (or group of entities) the right to develop, finance, design, build, own, operate and maintain the project in perpetuity. The public entity usually stipulates the general specifications to be followed by the private entity, which becomes the owner of the project taking on all the risks but also all of the surplus operating revenue. This model has been used in special cases, sometimes arising from a private initiative (hospitals, bridges, etc.).

Phases /Stages	Conceiving/Designing			Construction/Execution		Use/Utilization			
	Inception; Strategic planning; Initial studies	Programming; Briefing; Planning	Engineering; Design	Build; Construction; Execution	Commissioning; Start-up	Operation; Use; Utilization	Maintenance; Rehabilitation; Adaptive reuse	Deconstruction; Recycling; Demolition	
<b>Models</b>									
	+ Level of influence of the decisions - 								
Design-Bid-Build (DBB)	Owner / client		Designer	Constructor		Owner / User			
Design-Build (DB)	Owner/client (Designer)		Constructor			Owner / User			
Developer-Constructor	Owner / Constructor					Constructor / User			
Special cases of Public-Private Partnership (PPP)									
Design-Build-Operate-Maintain (DBOM/BOT)	Owner/client (Designer)		Constructor				Owner / User		
Design-Build-Finance-Operate (DBFO)	Owner/client (Designer)		Constructor (includes partial or total financing)				Owner / User		
Design-Build-Own-Operate (DBOO/BOO)	Constructor (includes financing)								

Figure 4 - Construction Management Systems/Models



## The construction industry and OSH

A brief characterization of the construction industry is given in subsection 31 together with some of the main OSH statistics. It shows that the industry is one of the main employers in many countries of the world, but also one in which a significant part of occupational accidents (especially, fatal accidents) occur.

Subsection 32 summarizes the main features of the construction industry and its OSH specificities. By showing the peculiarities of this industry, it allows a better definition of the procedures and methods for reducing accidents and professional diseases.

Finally, subsection 33 presents some of the conclusions of two important events in the European Union which may also be applied to other countries and may contribute to improve OSH in the construction industry. These conclusions are closely related to the issues and questions referred to in the previous subsection.

### 3.1 Characterization of the construction industry

The construction industry is one of the biggest industrial employers in many countries of the world. The ILO estimates the number of construction workers in the world at more than 110 millions<sup>1</sup> (usually, between 5 to 10% of the world's workforce), but in many countries double that number depend, directly or indirectly, on the construction sector.

The Confederation of International Contractors' Associations (CICA) estimates the world production by the construction industry at 3 to 4 billions ( $10^{12}$ ) of Euros. The gross domestic product (GDP) varies, sometimes significantly, among countries, but is usually between 5% to 15%.

In most countries, construction enterprises are micro (fewer than 10 workers), small (10 to 49 workers) or medium (50 to 249 workers) in terms of the number of workers they employ. In some regions (e.g. the European Union), the average number of workers per enterprise is estimated at 5 or 6. About one third of the workers are employed in micro-enterprises and almost two thirds in small or medium-size enterprises. Large enterprises (250 or more workers) employ a small number of workers.

The ILO estimates the number of fatal occupational accidents in the construction industry at about 60 000 every year [Valcárcel, 2003] with about 64% in the Asia and Pacific region, 17% in the Americas, 10% in Africa and 9% in Europe (Figure 5).

---

<sup>1</sup> Murie, Fiona (2007) from the International Federation of Building and Wood Workers, a federation of about 350 unions, states that the number of construction workers in the world is estimated at 180 million and the number of fatal accidents in this industry at 100 000 every year.

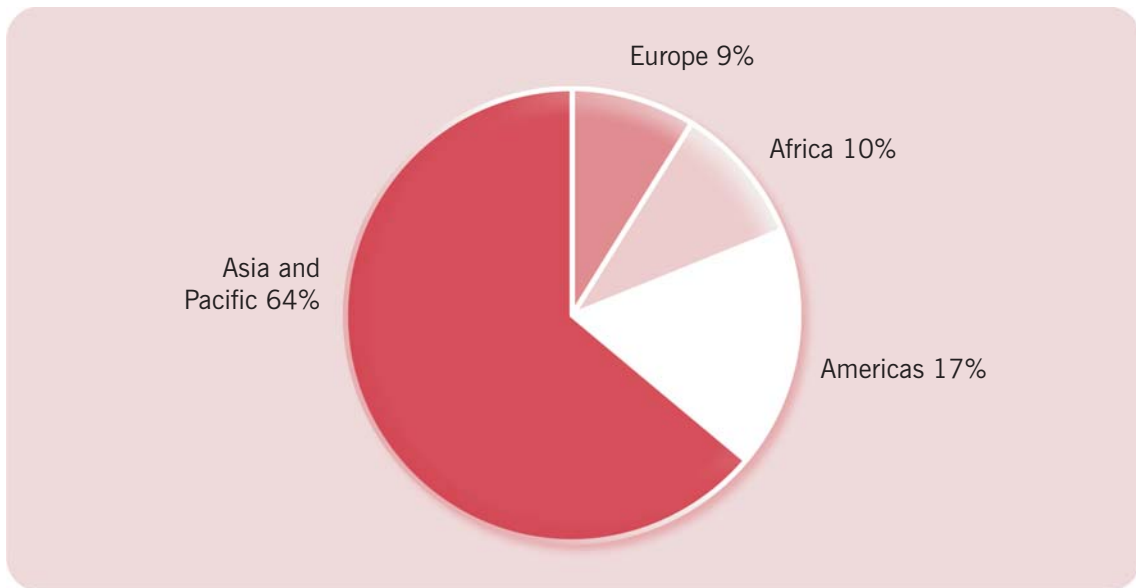

Figure 5 – Distribution of the fatal accidents in the construction industry

In many countries, there are twice as many occupational accidents leading to more than 3 days' absence in the construction industry as the proportion of construction workers to all industrial workers would lead us to expect, and three times as many fatal accidents (Figure 6).

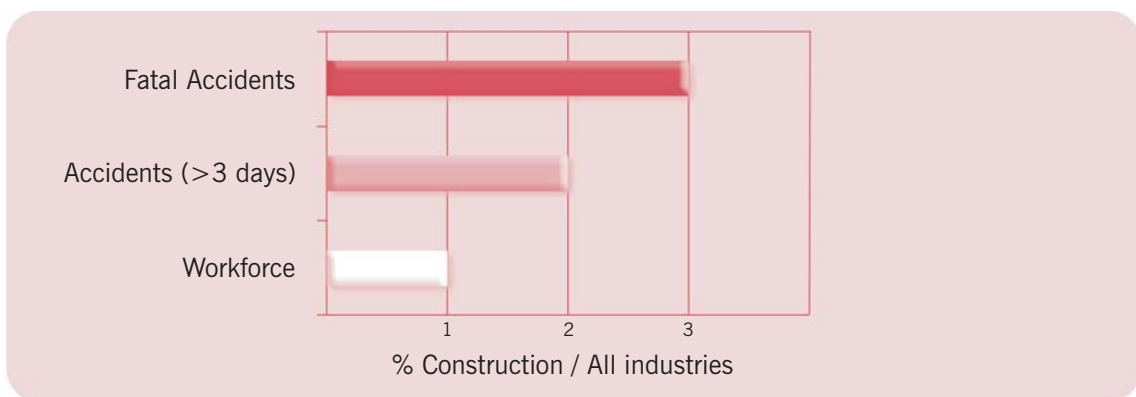

Figure 6 – Accidents in the construction industry versus all industries

## 3.2 Main features of the construction industry and its specific OSH features

The increasing competition among construction companies brings out the need to pay more attention to construction productivity issues.

The main objectives of any construction project are to avoid any negative environmental impact, to build with quality (avoiding defects), to ensure safety and health (avoiding occupational accidents and diseases), to meet the deadline and to minimize costs (Figure 7).



Figure 7 – The main elements/objectives to take into account in a construction project

Achieving these five objectives is very complex, in view of the inter-relationships among them and the pressure of the market to favour some of them (traditionally, cost and time) over those more related to society as a whole (environment, safety and health, and quality). There is, however, a strong belief that occupational safety and health should never be compromised in any circumstances, for social and human reasons.

The construction industry has changed in recent decades. Today, many of those involved in the construction process recognize the positive influence on productivity of good occupational safety and health. In other words, they recognize that prevention measures are an investment rather than a cost.

Studies in European Union countries and elsewhere have shown that the cost of occupational accidents is about double the cost of measures that would prevent them (European Commission, 2003) (Figure 8). These prevention measures consist of action during the design, the planning and the execution of the construction project.

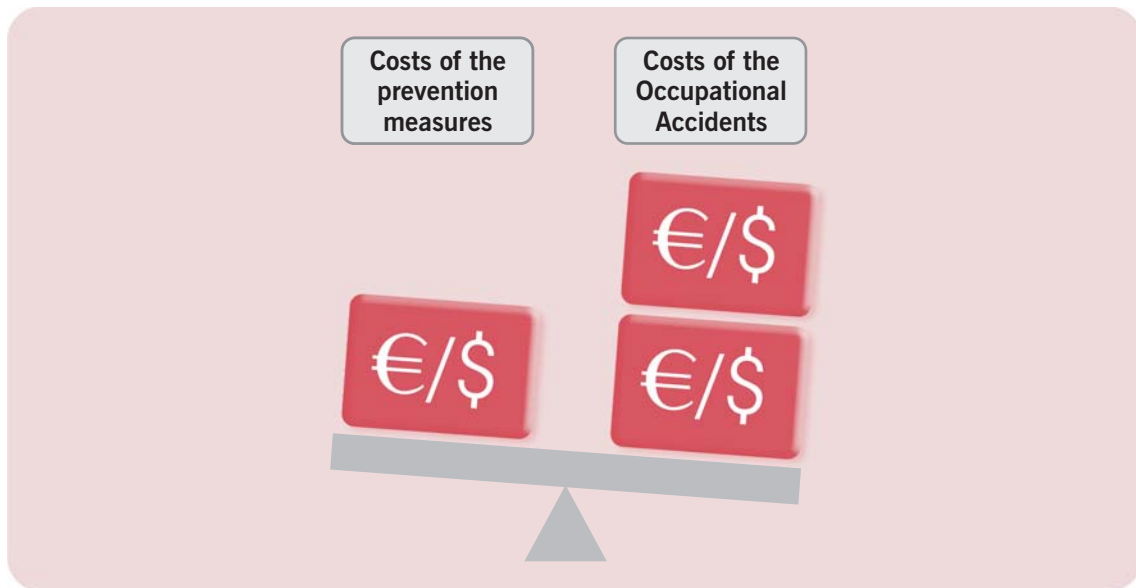

Figure 8 – Prevention costs versus occupational accidents costs

The construction industry is a hazardous industry. This statement has been repeatedly used by people involved in the construction process, to explain, at least in part, the high number of accidents and professional diseases in the industry. Meanwhile, more and more of them have been questioning the efficiency and the effectiveness of the existing systems for implementing and monitoring safety and health measures. However, all of them agree that if an accident happens, something has failed.

On the other hand, construction professionals know the hazards and the corresponding preventive measures; and in many cases those measures are being taken in most countries. Meanwhile, accidents continue to happen, although in some regions and countries there have been significantly fewer accidents (especially fatal accidents) in the last few decades.

This means that, in many cases, prevention measures are not being taken to “force” the bigger cut in the number of accidents that everyone wishes to see. In most countries, there are enough laws and regulations on OSH in construction, yet there is a failure to implement these laws and regulations. In view of this, some questions are:

- (i) Why are the existing laws and regulations not implemented in many cases?
- (ii) Why are prevention measures not implemented in many cases?

There is no single answer to these questions. Many arguments have been used to justify the non-implementation of existing laws and preventive measures. These include:

- the high number of existing OSH laws and regulations (sometimes more than 100), and the fact that they are prescriptive rather than performance-based;
- the OSH laws and regulations need adjusting to take into account the peculiarities of the construction industry (see below);
- the OSH laws and regulations keep changing, sometimes in a short period;
- the initial costs of prevention measures are high (failing to recognise how they benefit productivity and consequently on reducing costs);
- labour inspectors need to be more proactive and even reactive (failing to recognise that it is not possible to have an inspector for each construction site).

Moreover, the specific nature of the construction industry means that there is a need for tailor-made OSH laws and regulations. This, however, can never justify failure to implement the national laws and regulations or to take preventive measures. The specific features of this industry include:





- producing unique products (a building, a bridge, a road, etc.) unlike most other industries, which turn out products in series (usually making workplaces easier to control, although sometimes they, too, are complex, as in the chemical industry and others);
- many parties being involved in the different phases of a construction project, sometimes with different interests: owners (low cost, high quality); users (high quality of life, comfort); designers (aesthetics, structural safety); contractor and subcontractors (reduce costs, improve productivity); etc. (Do they all think about safety and health?);
- a high number of subcontractors (and their subcontracting chain) in construction projects, making the enforcement and inspection of OSH legislation, as well as the running of OSH training programmes, more difficult;
- construction companies more and more becoming “management and coordination companies” (outsourcing all or most of the construction works);
- subcontractors being the main employers (most of them are micro or small enterprises);
- being a labour-intensive activity (although often highly mechanized) ;
- “labour-only” subcontracting and self-employment on short-term contracts being common practice;
- payment on the basis of “work performed” (rather than hourly-based) becoming the most frequent method of payment in many countries (“favouring” a high number of working hours per day and working days per week);
- the highest rate of fatal and non-fatal accidents (in many countries sometimes more than 50% of all accidents in all industries);
- falling from height as the main cause of fatal accidents in most countries (sometimes more than 50% of fatal accidents in construction).

The governments and social partners in each country should reflect more deeply on all these features and, together, look for possible solutions at both the legislative level and the implementation level. It is the author’s belief that OSH legislation should be as simple as possible, and be as performance-based as possible (i.e. not too prescriptive), so that it is easy to implement by contractors and to inspect by labour inspectorates. Moreover, the owners/clients of the construction projects should be more involved in OSH issues.

### 3.3 Strategies for improving OSH in the construction industry

The issues referred to in the previous subsection have led many countries and regions to discuss ways to improve OSH in the construction industry. The European Union has seen two relevant events on these issues in recent years, the conclusions of which may also be applied elsewhere. The two events were held in 2004 and 2006 by the European Agency for Safety and Health at Work, based in Bilbao, Spain.

The main conclusions of the “European Construction Safety Summit” held in 2004 were published as the “Bilbao Declaration” (EASHW, 2004). They may be summarized as follows:

- **Procurement - building in safety:** OSH issues are integral to the construction project process. They are not confined to the construction phase of a project but occur throughout the entire lifetime of the project: design, construction, maintenance and demolition.
- **Enforcement - improving compliance:** Prevention is the guiding principle for OSH legislation in the European Union.
- **Guidelines - sharing good compliance practice:** OSH legislation needs to be accompanied by guidelines that can help to explain how the legal requirements can be implemented and in this way share good compliance practice.



- **Designing safe and healthy construction work:** this declaration calls on the design community in the European Union countries to design out risk wherever reasonably possible and to highlight any remaining residual risk in all projects.
- **Improving safety and health performance through social partner commitment:** Social dialogue and agreements on OSH improvements are key tools to ensure the indispensable commitment to real improvements in safety and health in construction workplaces.
- A final decision related to follow-up: all the signatories of the Bilbao Declaration were to meet again two years later. The follow-up meeting took place in September 2006, when the main conclusions were as follows (EASHW, 2006):
- The industry has made considerable effort to improve occupational safety and health, by working in cooperation with each other. The work done demonstrates what can be achieved by working together. Further improvements can only be achieved by collaborative effort with contractors, large and small, working together with the workers, architects, designers, engineers and surveyors. However, as discussed at the event they need help from outside.
- **Procurement:** the public sector should be exemplar procurers. Without the public sector setting these standards, how can private clients be influenced? More guidance is needed with leadership demonstrated at the highest level, and a shift away from simple applying “lowest cost” judgements.
- **Enforcement:** some delegates stressed the lack of consistency in enforcement. This leads to companies who apply the best standards, being unsuccessful with bids for tenders, and in many cases not even bidding, as they know it is a foregone conclusion that they will be unsuccessful. Sharing good practice requires those companies who use it, to operate in all Member States. These good practices can then spread to subcontractors and others and there should not be a different OSH regime over a border in a single market.
- **OSH Statistics:** work needs to be done to enable accurate comparisons between Member States.
- Over the last two years, following the European Construction Safety Summit, the European construction industry has made significant progress in improving safety, health and welfare. Now action is required to achieve change and to make a real and lasting impact on safety and health on Europe’s construction sites. This action is not just by the industry partners, continuing to work together, but by the others highlighted above - the regulators, the clients and information providers.

In addition, some countries and regions have made many changes to their OSH legislation in a search for continual improvement of the working conditions of construction workers and for fewer occupational accidents and less occupational diseases in this industry.

In some cases, these changes aim to comply with ILO Convention No. 167 (1988) on “Safety and Health in Construction”, which introduced a new approach to improving OSH in construction. The main features of this important Convention are summarized in section a), below. An example of this ILO approach in European Union countries is summarized in section b). Some recommendations which could improve OSH in the construction industry are made in section c).



### a) The ILO approach to improving OSH in construction (ILO Convention No. 167)

ILO Convention No. 167 (Safety and Health in Construction) has five sections: (i) scope and definitions; (ii) general provisions; (iii) preventive and protective measures; (iv) implementation; (v) final provisions. Of these, the general provisions (Figure 9) are the most important for the present document. The associated ILO Recommendation No. 175 helps us to understand and to interpret the Convention.

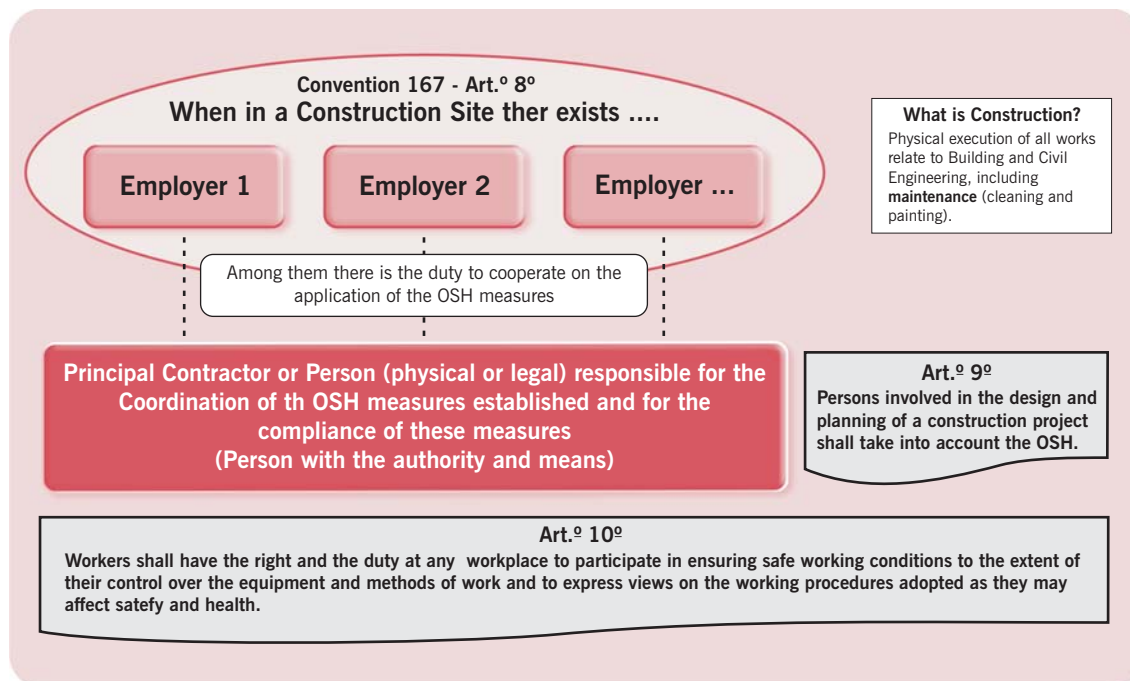

Figure 9 – The main general provisions of the ILO Convention 167

Member States that ratify Convention No. 167 should enact the necessary laws to make these provisions or adapt existing laws to accommodate them. Highlights of these general provisions are:

- The need to nominate a “Principal Contractor” or “Person” (physical or legal);
- the need for those involved in the design and planning of a construction project (e.g. managers and designers) to take OSH into account;
- the OSH of those who will be involved in the maintenance of the project should also be taken into account during the use or operation phase.

The “**Principal Contractor**” (not necessarily the general/main constructor, but certainly one of the constructors that know the construction process) or the “**Person**” (i.e. a competent person as defined in the Convention, who should have the authority and means to carry out his/her mission), should be responsible for coordination of the prescribed OSH measures and for ensuring compliance with such measures.

The legislation for this new “stakeholder” in the construction industry may be simple as regards construction projects where there is a general/main constructor, who may be appointed as “Principal Contractor”. However, where more than one constructor is involved, simultaneously or successively, or in construction projects where a “Person” (other than the general/main constructor or any of the constructors) is to be appointed, the legislation should stipulate which of the constructors should be appointed as “Principal Contractor” (in the meaning of the Convention) and/or the qualification (including the basic education, training, experience) of such a “Person”.

OSH should also be made the responsibility of those involved in the design and planning of a construction project, namely the project or construction managers and designers (not only of the construction project as the final product, but also of the temporary structures that are needed to build

it, like scaffoldings, formworks, guardrails, and other). This means that the managers and designers should answer questions like the following:

- How should the project be physically built while avoiding or minimizing the risks to the construction workers?
- How much time is needed to build the project (and each of its parts) while reducing the risk from too many workers in the same workplace or from tasks that may cause risks when performed at the same time?

For this purpose, the new OSH legislation should be inserted into the existing construction legislation on the responsibilities of managers and designers. The importance of this responsibility for OSH of those involved in the design and planning phases (i.e. before starting the execution phase) was illustrated by a study in the European Union in the 1980s, which concluded that more than 60% of fatal accidents in the construction industry could have been avoided by action before launching the construction site (Figure 10).

As for the maintenance of the construction project, the OSH should also be of concern, especially to designers, who should answer questions like the following:

- How can the construction project be maintained without putting at risk the workers involved in its maintenance?
- Exactly where (which parts?), when (which periodicity?) and how (e.g. means of access to the parts) should maintenance take place?

Although the Convention refers expressly to cleaning and painting, other issues should also be considered, for example inspection of the construction project, including the equipment (e.g. air conditioning) installed in it.

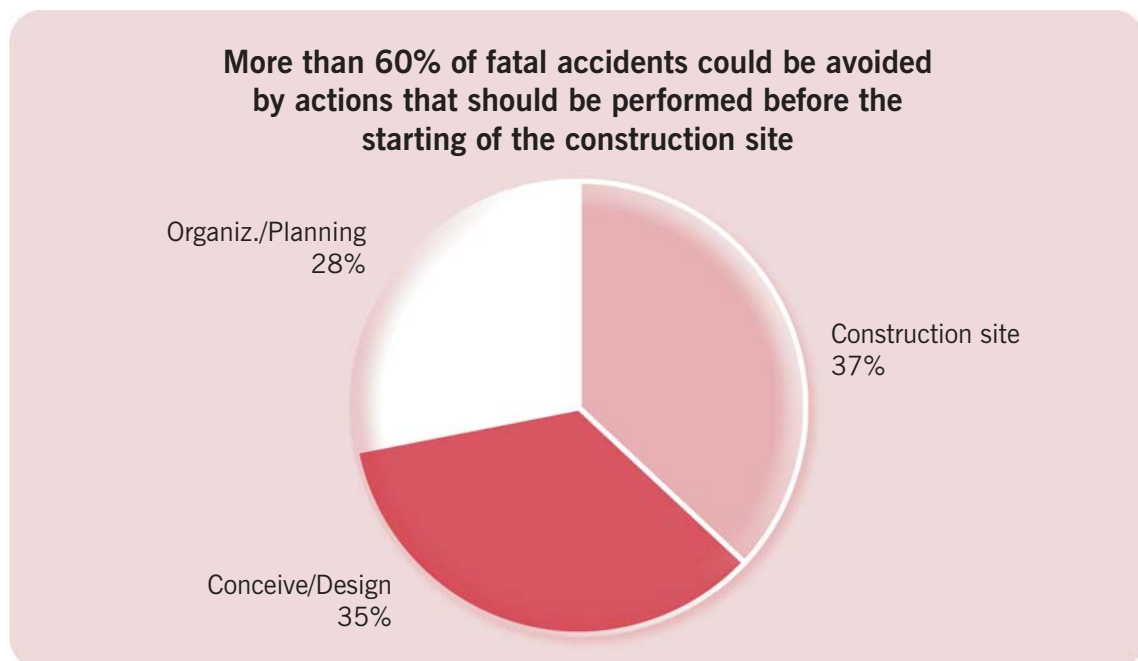

Figure 10 – Causes of fatal occupational accidents in construction

### b) The European Union approach to improving OSH in construction (EU Directive 92/57/EC)

One example of the ILO approach embodied in Convention No. 167 is the new methodology adopted by the European Union, which is summarized below.

Because the European Union (EU) recognized that construction was a highly hazardous industry, in 1992 it published a special Directive<sup>2</sup> (EU Directive No. 92/57/EC of June 1992) that changed the way safety and health in construction was seen. This Directive is now known worldwide as the Construction Sites Directive (CSD). Since then, the construction industry has changed in all countries of the European Union, and safety and health in construction is now an issue that most construction stakeholders are aware of and care about.

The high number of meetings, seminars, congresses and symposia organized since then in the EU countries has contributed significantly to this awareness. Despite this, there are still some stakeholders in some EU countries who continue to ignore their responsibilities for construction safety and health, especially owners and designers who traditionally held the view that safety and health on construction sites was the sole responsibility of the contractors. The official entities (governments and, in particular, labour inspectorates) should boost the awareness of these stakeholders through seminars related to their specific duties.

Since its publication, each country of the EU has brought the provisions of the CSD into national law. However, although some countries have made this Directive work by creating the mechanisms and means for effective implementation, others have made a “simple” transposition with few adaptations to their own situation, thereby sometimes creating confusion for those who must implement it or check its application every day. Other countries still have changed, or are changing, their first transposition, clarifying it and/or adding detail. In spite of the common base introduced by the CSD, the fact is that each country in the EU has its own approach.

Before the CSD was published in the European Union, the responsibility for the implementation of all prevention measures on construction sites was handed mainly (and in some countries, only) to the contractors, based on the legislation and/or on the contracts between the owners and those contractors. After the publication of the Directive, all those involved in the construction process (owners, designers, managers, supervisors, contractors, subcontractors and workers) have responsibilities and obligations for occupational safety and health matters.

The CSD introduced a new approach to the improvement of OSH in construction. It highlighted the importance of prevention measures (managerial and material) to reduce work-related accidents and diseases in construction. It took the provisions of ILO Convention No.167 on “Safety and Health in Construction” (1988) into account. In short, the approach of the CSD is based on (Figure 11):

- (i) the principle that all those involved in the construction process have specific roles and responsibilities concerning OSH, including the owner/client and designer;
- (ii) the new concept of safety and health coordination (for the design phase and for the construction phase), creating:
  - two new stakeholders in the construction process (safety and health coordinators for the design phase and for the construction phase) and;
  - three new documents concerning hazard prevention (the prior notice, the safety and health plan, and the safety and health file<sup>3</sup>).

<sup>2</sup> An EU Directive is an instrument (like a law) which is legally binding on every Member State of the European Union as regards the results to be achieved, but it needs to be transposed to the national law of each country, so it is up to each country to establish the way and means by which to achieve the results.

<sup>3</sup> The Prior Notice announces the opening of a new construction site, whereas the Safety and Health Plan and the Safety and Health File aim to identify and prevent hazards, the former during the construction phase and the latter during the maintenance phase.

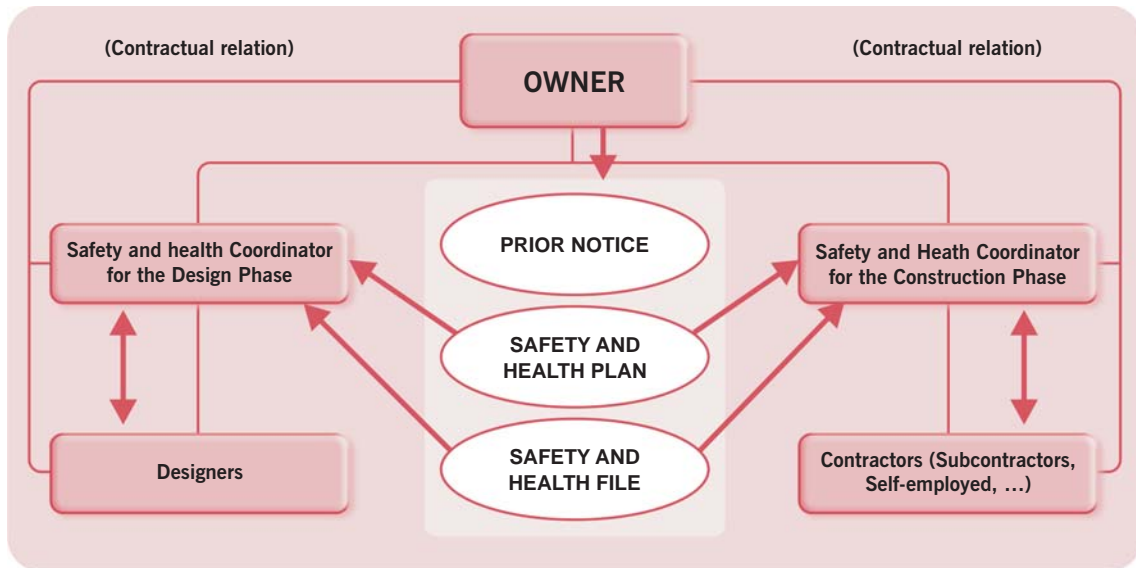

Figure 11 – The European Union approach (Directive 92/57/EEC)

The OSH roles of all those involved in the construction process, the new concept of safety and health coordination (both during the design phase and during the construction phase) and the new documents concerning hazard prevention are often described elsewhere and so lie beyond the scope of this document. However, some of the concepts and documents are referred to in this document, but in summary form.

### c) Recommendations on improving OSH in the construction industry

Taking into account the approaches mentioned in a) and b) above, and the experience of countries that already take them, a possible strategy for promoting and improving an effective OSH culture in the construction industry based on ILO values is summarised in Figure 12.

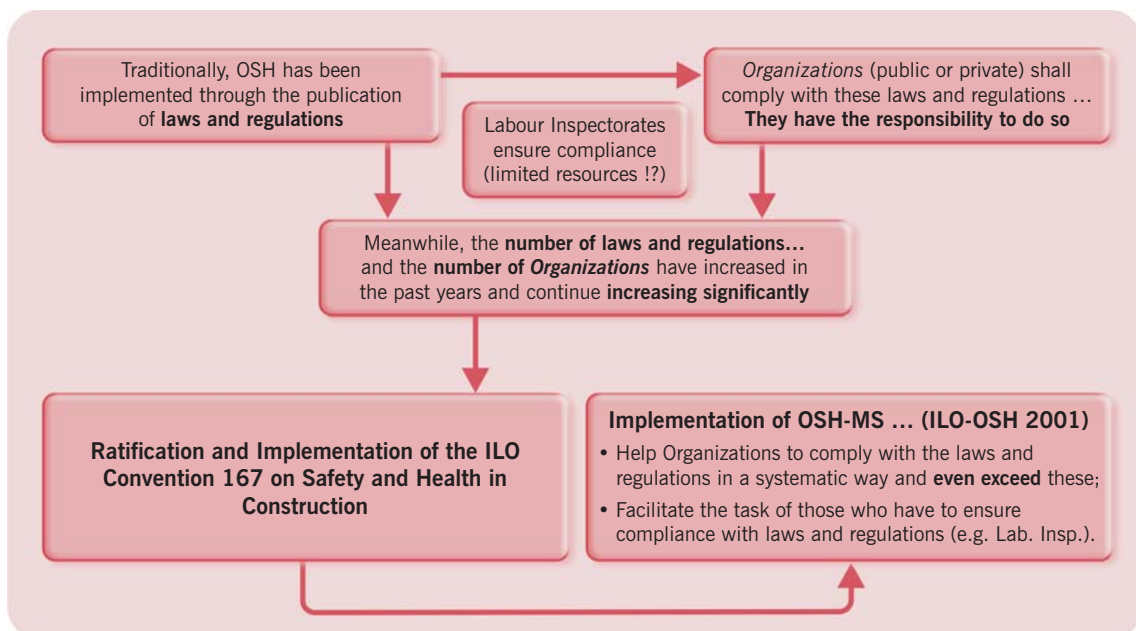

Figure 12 – A possible strategy for promoting and improving OSH in the construction industry



To improve OSH in the construction industry, the following steps are strongly recommended:

- Ratify ILO Convention No. 167 on safety and health in construction, taking into consideration the provisions of ILO Recommendation No. 175.
- Create and/or adapt the national laws and regulations on OSH to accommodate the provisions of the Convention (taking into account the associated Recommendation and the ILO Code of Practice published in 1992), by:
  - (i) setting out the rules for appointing the Principal Contractor and/or Person in charge of OSH issues during the design and planning phase and during the execution phase, stating whether they should be physical or legal persons;
  - (ii) specifying the qualifications of the Principal Contractor and/or Person in charge of OSH, be they physical or legal persons (in the latter case, they should involve a number of competent physical persons);
  - (iii) implementing OSH training programmes for the physical persons in charge of OSH issues;
  - (iv) promoting separate OSH training programs for each of the main stakeholders in the construction process, including representatives of the owners/clients, project and construction managers, designers (architects, engineers of the different specialities of the final product and of the temporary structures), OSH experts, etc.;
  - (v) establishing levels of requirements according to the size and complexity of the main types of construction projects (e.g. based on any existing classification of construction projects);
  - (vi) planning the implementation of the new laws and regulations by phases, i.e. fixing the appropriate periods of time for them to come into force and effectively applied, starting with the largest construction projects and ending to the smallest ones (the implementation of new technical laws or regulations to come into force immediately and for all construction projects is strongly discourage).
- Give priority to performance-based (instead of prescriptive) laws and regulations for technical legislation, namely that concerning the preventive and protective provisions, including details and examples of their implementation in mandatory and/or informative annexes for interpretation and clarification purposes; in some countries, the mandatory annexes have been established by the social partners in the construction industry;
- Hold separate meetings with the main owners (or with their associations, if they exist), the main associations of constructors and the main construction unions, in order to promote the implementation of the new laws and regulations, while making clear the responsibilities, competences, duties and rights of each of these groups;
- Implement tailored guidelines for OSH-MS in the construction industry based on ILO-OSH 2001 Guidelines (ILO, 2001a) and a public-based recognition system for construction enterprises wishing that their systems be recognised in a voluntary basis. The creation of incentive systems for those enterprises that implement and recognise their systems would be a good strategy. The implementation of an OSH-MS in a construction project will help the enterprises to comply with the laws and regulations more easily and systematically, while facilitating the task of those who have the duty of verifying compliance with such laws and regulations (OSH experts, labour inspectorates, etc.).

## Selection of construction enterprises and sites for inspection

The selection of construction enterprises and sites for inspection should follow previously defined criteria, taking into account the legislation and regulations of each country. These criteria may include many aspects which relate, directly or indirectly, to potential risks and so give information about the level of risk of each construction enterprise or project. Such criteria include:

- type of contract;
- number of contracts and subcontracts;
- number of workers;
- volume of construction work in monetary units;
- types of work;
- types of particular risk; and
- accident statistics for each enterprise compared with the national averages, where available.

Each may be applied at the construction enterprise level or at project level, and be subdivided for more detailed information (sub-criteria). For example, the number of workers should be the number of workers of the enterprise or construction project under consideration, which can be subdivided into the number of permanent workers and non-permanent workers (temporary workers, labour-only subcontracting, etc.).

This process of selecting construction enterprises or sites to be inspected is highly dependent on the national legislation obliging one or more of those involved in the construction process (in particular, the owners/clients) to inform the authorities (labour inspectorates and others depending on each country) that a construction site is to be started (Prior Notice). This is the case in all the countries of the European Union (and also elsewhere), where this obligation exists for all construction projects, under conditions listed in subsection 4.1 of this document.

This method is recommended for every country, taking into account the situation in the construction industry and the legislation of each country, which means that adjustments and simplifications may be needed.

On the other hand, other methods have been used for the selection of construction enterprises and sites for inspection, including:

- comparing the occupational accident statistics of each enterprise with the national figures for the construction industry, where this information exists and is reliable; enterprises with higher accident records than the national average should be inspected as a priority;
- casual visits by labour inspectors to the construction sites within the territory under their supervision, organised by region, city, or any other administrative division;
- a decision to inspect construction projects that involve many subcontractors and workers, considering as a good approach that the smaller enterprises (usually subcontractors) may learn from the large enterprises;
- other decisions based on the high risk involved (e.g. a scaffolding in a specific visible place in a city, which should exemplify good practice).

These methods should continue to be applied, as there will be always situations that justify their use.





Subsection 4.1 addresses the Prior Notice. Subsection 4.2 includes a method for the selection of construction sites for inspection, from which another method is also proposed in subsection 4.3 for the selection of enterprises for inspection.

## 4.1 Prior Notice of a construction project

A structured method for the selection of construction projects to be inspected (and consequently, also for the inspection of enterprises as referred to above) should be based on an analysis of relevant information related to each of them.

This means that the method depends on the availability and reliability of the information needed and so it is recommended that in every country the legislation require a Prior Notice.

This Prior Notice (PN) aims to inform the competent authorities (labour inspectorate and others, depending on the law of each country) that a construction site will start and so it should be prepared before any work on the site. It must be clear displayed on the construction site and be periodically updated, if necessary.

In the European Union the conditions to prepare this document varies for each country. According to the Construction Sites Directive (92/57/EEC, 1992), this Prior Notice is mandatory whenever:

- the works are scheduled to last longer than 30 working days and on which more than 20 workers are occupied simultaneously; or
- the volume of work is schedule to exceed 500 person-days (i.e. the sum of the working days of all workers).

This means, for example, that in a construction project employing 10 workers every day for 6 months (this could be for one small house), a Prior Notice is necessary, as it involves a volume of 1200 person-days ( $6 \times 20 \times 10 = 1200$ ), assuming 20 working days per month and that there are the same number of workers every day), even though the first condition is not fulfilled (i.e. the period of time is more than 30 days, but no more than 20 workers are occupied simultaneously).

The minimum content of this Prior Notice, according to the mentioned EU Directive, is presented in the following Table 1, together with notes. However, in many countries, other information has been included in this document to take into account the situation in the construction industry in each country (e.g. the safety experts acting on behalf of the constructor, other than the safety and health coordinators).



**Table 1: Content of the Prior Notice**

(1) Date of forwarding to the authorities;
(2) Exact address of the construction site;
(3) Client(s) including name(s) and address(es); <i>(while for private projects the client is easy to identify, for public projects the client will depend on the legislation applicable)</i>
(4) Type of project; <i>(including a description of the project to enlighten the type of hazards involved and taking into account the working environment; the details of this description is important to Labour Inspectorates to decide whether they should inspect or not the construction site in view of the hazards it may involved)</i>
(5) Project supervisor(s) including name(s) and address(es); <i>(client's representative and so an agent of the client)</i>
(6) Coordinator(s) for safety and health matters during the project preparation stage (design phase), including name(s) and address(es); <i>(new stakeholder acting on behalf of the client – he is an agent of the client for the design phase)</i>
(7) Coordinator(s) for safety and health matters during the project execution stage (construction phase), including name(s) and address(es); <i>(new stakeholder acting on behalf of the client – he is an agent of the client for the execution phase)</i>
(8) Date planned for start of work on the construction site; <i>(including the temporary works, as for the social installations)</i>
(9) Planned duration of work on the construction site; <i>(the client should base this duration on a real planning of the project that should be prepared by their agents involved pre-construction phase – project supervisor, designer, coordinator for safety and health)</i>
(10) Estimated maximum number of workers on the construction site; <i>(this corresponds to the peak of the normal distribution of labour on the construction site; this maximum number of workers is obtained from the planning of the construction project, usually, made by the Constructor)</i>
(11) Planned number of contractors and self-employed persons on the construction site; <i>(includes all subcontracting chain and this information should be given separately as for the workers of constructors, labour-only contractors, temporary workers, self-employed, etc. )</i>
(12) Details of contractors already chosen. <i>(in some countries, this has been required just for the constructors and sub-constructors)</i>

Moreover, many countries have added details to clarify its content (e.g. listing the number of self-employed workers separately, or subtracting labour-only subcontractors from the number of sub-constructors).

The Prior Notice is a responsibility of the client (or owner), although some information to include in it should be obtained from the constructor. In some countries, the law also calls for a written declaration of acceptance by all those included in this Prior Notice, in particular those parties that are external to the owner's set-up, namely the safety and health coordinators.

It is also the author's belief that, where appropriate, this declaration should also refer to the feasibility of the time established for the project to be executed. This is important for supervisors, designers and safety and health coordinators, due to the influence it has on safety and health (a short time means a concentration of workers and potential incompatibility among simultaneous jobs, making accidents more likely). Other information that should be added (or just included as an attachment to the Prior Notice) relates to the method for selecting construction projects to inspect (e.g. the table referred in subsection 4.2).

This Prior Notice is to be presented, according to the mentioned EU Directive, before the construction site starts work (and not before the design phase), and so during the design phase there is a lack of information about the projects that are being developed, except in some "design-build" or PPP contracts (see 2.2 - Key construction concepts). Although in some EU countries there are penalties for the non accomplishment of the duties of the designers, the competent authorities cannot intervene during this phase as they have no information about them. There may be an opportunity for the authorities to analyse the designs during the construction phase, although this is rare.

Moreover, when the construction site closes, it should be required a Final Notice with the information in the Prior Notice (including the annexe) updated (or the last update of the Prior Notice that has been sent to the authorities according to the national law). It should also inform the competent authorities that the construction site has closed. This Final Notice allows a better selection of the enterprises to be inspected, as stated in subsection 4.3.



It is strongly recommend that specific forms be prepared for both the Prior Notice and the Final Notice, including the necessary means for sending them by electronic means (e.g. e-mail) to the competent authorities. This simplifies the processing of the information in both these documents, and consequently allows a better and simpler selection of construction sites and enterprises to be inspected.

## 4.2 Method for selecting construction sites to be inspected

The method presented below is based on the information contained in the Prior Notice (or the Final Notice, if it exists), which may include (as an attachment) other information needed for the implementation of the proposed method.

This additional information includes the following: type of contract; number of contracts and subcontracts; number of workers; volume of construction work in monetary units; types of work; types of particular risk.

These criteria may be used in isolation or in combination for a single construction site. All these criteria should be analysed in terms of the hazards they may involve (e.g. the construction of a bridge involves higher risks than the construction of a small building). A combination of more than one of these criteria is recommended. Each criterion should be weighted.

For this purpose, two levels are proposed:

- summary evaluation (1<sup>st</sup> level); and
- detailed evaluation (2<sup>nd</sup> level).

Table 2 lists possible criteria for the summary evaluation (1<sup>st</sup> level). Table 3 list possible criteria and sub-criteria for the detailed evaluation (2<sup>nd</sup> level) providing better information and so it should be followed whenever possible.

**Table 2: Possible criteria for the selection of construction sites (1<sup>st</sup> Level)**

Construction Site:								Reference/Date			
Nr.	Criteria	Data or Remarks (1)	W <sub>i</sub> <sup>(2)</sup> (1 - 5)	A <sub>i</sub> - Assessment <sup>(3)</sup>						Weighted Eval. E <sub>i</sub> <sup>(4)</sup>	INFO N. <sup>(5)</sup>
				0	1	2	3	4	5		
1.	General information			—	—	—	—	—	—		
1.1.	Organizational flowchart and human resources on site										
1.2.	Past behaviour on OSH of each of the main stakeholders										
1.3.	OSH-MS (ILO-OSH 2001) implemented on site										
1.4.	Type of contract										
1.5.	Type of construction project										
2.	Volume of work in monetary units (total)										
3.	Number of contracts and subcontracts										
4.	Number of workers (maximum)										
5.	Type of works involved										
6.	Types of particular hazards involved										
7.	Free										
8.	Free										
<b>Totals</b> (number of possible points, cases evaluated with 0, 1, ...5 and total weighted points) - >											
<b>Evaluation of the Construction Site - &gt;</b>											

**Table 3: Possible criteria for the selection of construction sites (2nd Level)**

Construction Site:								Reference/Date		
Nr.	Criteria	Data or Remarks (1)	Wi <sup>(2)</sup> (1 - 5)	Ai - Assessment <sup>(3)</sup>					Weighted Eval. Ei <sup>(4)</sup>	INFO N. <sup>(5)</sup>
				0	1	2	3	4		
<b>1.</b>	<b>General information</b>		—	—	—	—	—	—	—	
1.1.	Organizational flowchart and human resources on site		—	—	—	—	—	—	—	
	a) Suitability and sufficiency of the OSH resources on site									
	b) Description of documented tasks of those with OSH responsibilities at the management level									
	c) Documented identification and number of worker's representatives according to the law									
	d) Description of documented tasks for worker's representatives and means provided to accomplish them									
	e) Free									
	f) Free									
1.2.	Past behaviour on OSH of each of the main stakeholders									
	a) Owner									
	b) Designers									
	c) Project supervisors									
	d) OSH Coordinators or Owner's OSH expert									
	e) Constructor(s)									
	f) Constructors' OSH experts									
	g) Free									
1.3.	OSH-MS (ILO-OSH 2001) implemented on site									
1.4.	Type of contract (tick below just one)		—	—	—	—	—	—	—	
	a) Design-Bid-Build (DBB)			—	—	—	—	—		
	b) Design-Build (DB)			—	—	—	—	—		
	c) Developer-Constructor			—	—	—	—	—		
	d) Design-Build-Operate-Maintain (DBOM/BOT)			—	—	—	—	—		
	e) Design-Build-Finance-Operate (DBFO)			—	—	—	—	—		
	f) Design-Build-Own-Operate (DBOO/BOO)			—	—	—	—	—		
	g) Free			—	—	—	—	—		
1.5.	Type of construction project (tick below just one)		—	—	—	—	—	—	—	
	a) Building			—	—	—	—	—		
	b) Bridge			—	—	—	—	—		
	c) Viaduct (including under and over passages)			—	—	—	—	—		
	d) Roads and highways			—	—	—	—	—		
	e) Dams			—	—	—	—	—		
	f) Water supply and sewage drainage			—	—	—	—	—		
	g) Free			—	—	—	—	—		
<b>2.</b>	<b>Volume of work in monetary units (total)</b>		%							
2.1.	Labour, including labour-subcontracting									
2.2.	Material, including incorporated equipment									
2.3.	Equipment (non incorporated, like cranes, etc.)									
2.4.	Subcontracts (work-performed based)									
2.5.	Free									
<b>3.</b>	<b>Number of contracts and subcontracts</b>		%							
3.1.	Contracts (i.e. contractors coordinated by the client)									
3.2.	Subcontracts (work-performed based)									
3.3.	Subcontracts (labour-only)									
3.4.	Successive chain of subcontracts (2nd and lower levels)									
3.5.	Free									



Construction Site:										Reference/Date	
Nr.	Criteria	Data or Remarks (1)	Wi <sup>(2)</sup> (1 - 5)	Ai - Assessment <sup>(3)</sup>					Weighted Eval. E <sub>i</sub> <sup>(4)</sup>	INFO N. <sup>(5)</sup>	
				0	1	2	3	4			5
<b>4.</b>	<b>Number of workers (maximum)</b>		%								
4.1.	Permanent workers										
4.2.	Temporary workers (time-based)										
4.3.	Labour-subcontracting workers										
4.4.	Other workers engaged by subcontractors										
4.5.	Free										
<b>5.</b>	<b>Types of work involved</b>		—	—	—	—	—	—	—		
5.1.	Excavation										
5.2.	Earthworks										
5.3.	Construction										
5.4.	Assembly and disassembly of prefabricated elements										
5.5.	Conversion or fitting-out										
5.6.	Alterations										
5.7.	Renovation										
5.8.	Repairs										
5.9.	Dismantling										
5.10.	Demolition										
5.11.	Upkeep										
5.12.	Maintenance (Painting, cleaning works)										
5.13.	Drainage										
5.14.	Free										
<b>6.</b>	<b>Types of particular hazards involved</b>		—	—	—	—	—	—	—		
6.1.	Burial under earth-falls (particularly if more than 1,50 m)										
6.2.	Engulfment in swampland										
6.3.	Falling from a height (particularly if more than 3 m)										
6.4.	Ionizing radiation										
6.5.	Work near high voltage power lines (close to 5 meters)										
6.6.	Work near railway lines (close to 2 meters)										
6.7.	Work exposing workers to the risk of drowning										
6.8.	Work on wells, underground earthworks and tunnels										
6.9.	Work carried out by divers having a system of air supply										
6.10.	Work in caisson with a compressed-air atmosphere.										
6.11.	Work involving the use of explosives.										
6.12.	Assembly or dismantling of heavy prefabricated components										
6.13.	Free										
<b>7.</b>	<b>Free</b>										
7.1.	Free										
7.2.	Free										
<b>8.</b>	<b>Free</b>										
8.1.	Free										
8.2.	Free										
<b>Totals</b> (number of possible points, cases evaluated with 0, 1, ...5 and total weighted points) - >											
<b>Evaluation of the Construction Site - &gt;</b>											

<sup>(1)</sup> Data or remarks = Information related to the criteria.

<sup>(2)</sup> W<sub>i</sub> = Weight of the criteria *i* rated out between 1 and 5: W<sub>i</sub> = 1, means "least important" or "little influence on the potential risks involved"; W<sub>i</sub> = 5, means "absolutely important" or "great influence on the potential risks involved".

<sup>(3)</sup> A<sub>i</sub> = Assessment of each criteria *i* rated out between 0 and 5: A<sub>i</sub> = 0 means "little influence on the potential risks involved" or "little attention is required"; A<sub>i</sub> = 5 means "great influence on the potential risks involved" or "great attention is required".

<sup>(4)</sup> E<sub>i</sub> = Weighted evaluation of each of the criteria *i*.

<sup>(5)</sup> INFO - A reference (sequential) number in this column means the reference to a document that supports the evaluation, e.g., notes, comments, etc..



Each country may adopt or adapt different criteria and/or sub-criteria to accommodate its own practice and situation. A detailed definition of each criterion should be attached to the tables.

Each of the criteria should be weighted ( $W_i$ ) between 1 and 5, with 1 meaning “least important” or “little influence on the potential risks involved” and 5 “most important” or “great influence on the potential risks involved”.  $W_i$  represents the weight of the criterion  $i$  from 1 to  $n$  (number of criteria considered). These weights should be defined following the procedure referred in subsection 4.4.

For each construction site, an assessment of the data related to each of these criteria should be analysed and evaluated. Each of the criteria should be rated ( $A_i$ ) between 0 and 5, where 0 means “little influence on the potential risks” or, where applicable, “no attention is required” and 5 means “great influence on the potential risks involved” or, where applicable, “special attention is required”. Therefore,  $A_i$  represents the assessment of the criterion  $i$  from 0 to 5, where higher figures means a higher risk construction site.

For example, the assessment ( $A_i$ ) should be higher (close to five) where many particular risks are estimated to be involved and/or the data related to the criteria may reveal a higher probability for the occurrence of risk (e.g. high number of temporary workers compared with the total number of workers on site). On the other hand,  $A_i$  should be close to zero (or even zero) if the data related to the criterion reveals that no or lesser attention is required (e.g. if there is an occupational safety and health management system implemented, than little or no attention may be required).

The weighted evaluation of each of the criteria ( $E_i$ ) and the evaluation of the construction site ( $E$ ) in terms of percentage (total weighted points obtained divided by the total possible points), are obtained using the following formulae, where “ $n$ ” is the number of criteria checked:

$$E_i = W_i \times A_i \quad (1) \quad E = \frac{\sum_{i=1}^n E_i}{5 \times \sum_{i=1}^n W_i} \quad (2)$$

The weighted evaluation of each “2<sup>nd</sup> level” criteria is obtained by the formula (3) below, and the weighted evaluation of each group of sub-criteria to be transferred to the corresponding “1<sup>st</sup> level” criteria, is obtained by the formula (4), where “ $m$ ” is the number of the sub-criteria of each group.

$$E_k = W_k \times A_k \quad (3) \quad E_i = W_i \frac{\sum_{k=1}^m E_k}{5 \times \sum_{k=1}^m W_k} \quad (4)$$

These formulae are similar to those presented above, but using the letter “ $k$ ” instead of “ $i$ ” to mean the items of the 2<sup>nd</sup> level. For example, while  $W_i$  means the weight of criterion “ $i$ ” of the first level (summary evaluation),  $W_k$  means the weight of criterion “ $k$ ” of the second level (detailed evaluation).

For example, in a construction site where only two criteria or sub-criteria are used with  $W_1 = 3$  and  $W_2 = 4$ , and assessments  $A_1 = 2$  and  $A_2 = 5$ , respectively, the evaluation of this construction site ( $E$ ) would be:  $E = 74\%$ , i.e.,  $(3 \times 2 + 4 \times 5) / [(3 + 4) \times 5] = 26 / 35 = 0,74 \times 100 = 74\%$ .

The column referred to as “INFO” (information) in the above tables, may be used to record a reference number (e.g. sequential number) referring to a document that supports the evaluation (e.g., notes, comments).

Using this method for the different construction projects under the supervision of a labour inspectorate (or delegation for a region or city), those to be inspected as a priority should be those with higher percentages, i.e. those where more risks are estimated to be involved.



### Key points to be inspected at the construction site level

Table 2 and Table 3 above give also the main key points to be inspected at the construction site level. The use of checklists like those presented in these tables, aims to help the labour inspectors to perform the inspections in a systematic way.

## 4.3 Method for selecting construction enterprises to be inspected

There are many different methods for selecting construction enterprises to be inspected, including decisions based on one or more of the criteria referred to in 2 above, but taking into consideration the information related to the enterprise instead of a specific construction project.

However, the following ways to select construction enterprises to inspect may be considered:

- Analysis of the occupational accident statistics of each enterprise;
- Analysis of all the evaluations of the construction sites of each enterprise.

The first method (selection based on accident statistics) should be used whenever there is a well defined official statistic system implemented in the country and the information given by each enterprise follows the same procedures of the official information and accuracy is assured.

In some countries this information may not be easy to obtain from official bodies, especially for individual enterprises, for reasons including confidentiality. However, the labour inspectorates may use their in-house information about each enterprise based on the occupational accidents that are reported to them in accordance with national law (usually, the fatal and severe accidents).

In this method, all enterprises may be grouped into different levels according to the accident statistics they have reported, using the OSH statistic indicators as referred to in the Resolution of the Sixteenth International Conference of the Labour Statisticians (ILO, 1998), which are summarised in subsection 8.3.

Those construction enterprises with higher OSH indicators in the past year (or a group of past years taken together, say 3 years) than the national average for the construction industry, will be given priority for inspection. This may also be more detailed if it uses subgroups based on the type of construction project (building, bridges, roads, etc.), for these involve different levels of risk.

The second method (analysis of all the evaluations of the construction sites of each enterprise) uses the information of the Prior Notice (or the Final Notice, if it exists) and the attachment to it. This method may be better than the previous one, as it combines statistical indicators with information specific to each enterprise.

This method follows a similar procedure to the one referred above for the selection of construction sites. Table 4 and Table 5, respectively, for the 1<sup>st</sup> and 2<sup>nd</sup> levels, may be used for this purpose, in which most of the criteria are the same, but refer to the entire enterprise instead of a single construction project. However, some criteria were added. Each country may adopt or adapt different criteria to accommodate practice and the situation within it. A detailed definition of each criterion should be attached to the table.

**Table 4: Possible criteria for the selection of construction enterprises (1<sup>st</sup> Level)**

Construction Enterprise:										Reference Year(s)	
Nr.	Criteria <small>(All the information should be referred to the mentioned reference years)</small>	Data or Remarks <small>(1)</small>	W <sub>i</sub> <sup>(2)</sup> <small>(1 - 5)</small>	A <sub>i</sub> - Assessment <sup>(3)</sup>						Weighted Eval. E <sub>i</sub> <sup>(4)</sup>	INFO N. <sup>(5)</sup>
				0	1	2	3	4	5		
<b>1.</b>	<b>General information</b>		—	—	—	—	—	—	—	—	
1.1.	Organizational flowchart and human resources										
1.2.	Knowledge of the past behaviour on OSH of each of the enterprise										
1.3.	Net profit (total, positive or negative)										
1.4.	OSH management system (ILO-OSH 2001) implemented										
1.5.	Statistics of occupational accidents										
1.6.	Free										
<b>2.</b>	<b>Number of contracts of each type (total)</b>										
<b>3.</b>	<b>Number of construction projects of each type (total)</b>										
<b>4.</b>	<b>Volume of work in monetary units (average per year)</b>										
<b>5.</b>	<b>Number of subcontractors (average per year)</b>										
<b>6.</b>	<b>Number of workers (average per year)</b>										
<b>7.</b>	<b>Number of accidents, fatal and non fatal, by causes (total)</b>										
<b>8.</b>	Free										
<b>9.</b>	Free										
<b>Totals</b> (number of cases evaluated with “yes”, “no”, 0, 1, ...5 and total weighted points) - >											
<b>Evaluation of the Construction Enterprise - &gt;</b>											

**Table 5: Possible criteria for the selection of construction enterprises (2<sup>nd</sup> Level)**

Construction Enterprise:										Reference Year(s)	
Nr.	Criteria <small>(All the information should be referred to the mentioned reference years)</small>	Data or Remarks <small>(1)</small>	W <sub>i</sub> <sup>(2)</sup> <small>(1 - 5)</small>	A <sub>i</sub> - Assessment <sup>(3)</sup>						Weighted Eval. E <sub>i</sub> <sup>(4)</sup>	INFO N. <sup>(5)</sup>
				0	1	2	3	4	5		
<b>1.</b>	<b>General information</b>		—	—	—	—	—	—	—	—	
1.1.	Organizational flowchart and human resources										
	a) Suitability and sufficiency of the OSH resources										
	b) Description of documented tasks of those with OSH responsibilities at the management level										
	c) Documented identification and number of worker's representatives according to the law										
	d) Description of documented tasks for worker's representatives and means provided to accomplish them										
	e) Free										
1.2.	Knowledge of the past behaviour on OSH of each of the enterprise										
1.3.	Net profit (total, positive or negative)										
1.4.	OSH management system (ILO-OSH 2001) implemented										
1.5.	Statistics of occupational accidents (> 3 days absence)										
	a) Number of accidents										
	b) Incidence rate										
	c) Frequency rate										
	d) <u>Severity rate</u>										
	e) Days lost per accident										
1.6.	Free										



Construction Enterprise:										Reference Year(s)	
Nr.	Criteria <small>(All the information should be referred to the mentioned reference years)</small>	Data or Remarks <small>(1)</small>	W <sub>i</sub> <sup>(2)</sup> <small>(1 - 5)</small>	A <sub>i</sub> - Assessment <sup>(3)</sup>						Weighted Eval. E <sub>i</sub> <sup>(4)</sup>	INFO N. <sup>(5)</sup>
				0	1	2	3	4	5		
<b>2.</b>	<b>Number of contracts of each type (total)</b>		—	—	—	—	—	—			
2.1.	Design-Bid-Build (DBB)										
2.2.	Design-Build (DB)										
2.3.	Developer-Constructor										
2.4.	Design-Build-Operate-Maintain (DBOM/BOT)										
2.5.	Design-Build-Finance-Operate (DBFO)										
2.6.	Design-Build-Own-Operate (DBOO/BOO)										
2.7.	Free										
<b>3.</b>	<b>Number of construction projects of each type (total)</b>		—	—	—	—	—	—			
3.1.	Building										
3.2.	Bridge										
3.3.	Viaduct (including under and over passages)										
3.4.	Roads and highways										
3.5.	Dams										
3.6.	Water supply and sewage										
3.7.	Rehabilitation works (renovations, alterations, etc.)										
3.8.	Free										
<b>4.</b>	<b>Volume of work in monetary units (average per year)</b>		—	—	—	—	—	—			
4.1.	Labour, including labour-subcontracting										
4.2.	Material, including incorporated equipment										
4.3.	Equipment (non incorporated, like cranes, etc.)										
4.4.	Subcontracts (work-performed based)										
<b>5.</b>	<b>Number of subcontractors (average per year)</b>		—	—	—	—	—	—			
5.1.	Subcontracts (work-performed based)										
5.2.	Subcontracts (labour-only)										
5.3.	Free										
<b>6.</b>	<b>Number of workers (average per year)</b>		—	—	—	—	—	—			
6.1.	Permanent workers										
6.2.	Temporary workers (time-based)										
6.3.	Non national workers (permanent or temporary)										
6.4.	Number of nationalities of the non national workers										
<b>7.</b>	<b>Number of accidents, fatal and non fatal, by causes (total)</b>		—	—	—	—	—	—			
7.1.	Falls from height (from floors, scaffoldings, roofs, etc.)										
7.2.	Caught in/between (malfunction of machinery, etc.)										
7.3.	Struck by (falling objects, etc.)										
7.4.	Cave in										
7.5.	Electrocution (power lines, power tools, etc)										
7.6.	Other causes										
7.7.	Free										
<b>8.</b>	<b>Free</b>										
8.1.	Free										
8.2.	Free										
<b>9.</b>	<b>Free</b>										
9.1.	Free										
9.2.	Free										
<b>Totals</b> (number of cases evaluated with "yes", "no", 0, 1, ...5 and total weighted points) - >											
<b>Evaluation of the Construction Enterprise - &gt;</b>											





All the information in these tables should be for the reference years (e.g. previous year, or the last 3 years taken together or on average).

Some additional information related to each construction enterprise may be needed to evaluate a specific criterion. This is the case, for example, of the OSH management system that the enterprise may have implemented in a formal way, where a “letter of recognition” should be available, i.e., an “official” document proving that the system conforms to the national or tailored guidelines (preference should be given to those systems that were implemented based on the national or tailored guidelines following the ILO-OSH 2001 guidelines and recognised by an accredited body).

The implementation and formulae of this method are the same as for selecting of construction sites for inspection (subsection 4.2).

Using this process for the different construction enterprises under the supervision of a labour inspectorate (or delegation for a region or city), those to be inspected as a priority should be those with higher percentages, i.e. those which are estimated to involve more risks.

### Key points to be inspected at the construction enterprise level

Table 4 and Table 5 above give also the main key points to be inspected at the construction enterprise level. The use of checklists like those presented in these tables, aims to help the labour inspectors to perform the inspections in a systematic way.

## 4.4 Procedure to establishing the relative weights

In the multi-criteria methods (like those used in this document for the evaluation of construction enterprises and sites), the weights of each of the criteria (and/or sub-criteria) have a major influence on the evaluation process.

In view of this, it is recommended to establish these weights in relative terms, by comparing each of the criteria with each of the others (i.e., by pairs) and decide which is more important than the other. This reduces significantly the subjectivity on the weights.

This procedure should be used among all the criteria and/or sub-criteria of the same group. For example, the criteria and/or sub-criteria in first level of the checklists included in this document for the evaluation of construction enterprises or sites, forms a group and so their relative weights is important to assure. Moreover, each of the criteria in the second level checklist is subdivided in a number of sub-criteria and so each of these criteria forms a different group for which the relative weights should also be assured.

For this purpose, comparing the criteria A with criteria B (or sub-criteria), it should be assigned the following values: 1 (one), if the criteria A is more important than criteria B; 0 (zero), if both criteria A and B have the same importance, i.e., the criteria A is as much important as the criteria B; -1 (minus one), if criteria A is less important than criteria B.

At the practical level, a square matrix ( $n \times n$ ) with the number of criteria and/or sub-criteria (those to be compared) placed in both lines and columns should be organised. In this matrix each element  $V_{ij}$  (interception of each line with each column) means the value (level of importance) of the criteria  $i$  compared with the criteria  $j$ .

It should be noted that the value assigned when comparing A and B is the symmetric of the value when comparing B and A (i.e., for example, if A is more important than B, then B is less important than A)<sup>4</sup>. Summing the values assigned to each of the criteria in lines, i.e.  $V_i = \sum V_{ij}$   $j=1$  to  $n$ , the most important

<sup>4</sup> Mathematically, this matrix is called anti-symmetric matrix, where  $V_{ij} = -V_{ji}$ .



criteria will be the criteria with the highest value  $V_i$  (i.e.  $V_{max}$ ), summing the positives and negatives values, and the less important criteria will be the lowest value  $V_i$  (i.e.  $V_{min}$ ). Based on these values, the relative weights of each of the criteria ( $W_i$ ) will be given by the following formula that converts the values  $V_i$  to the scale of 1 to 5 above mentioned<sup>5</sup>:

$$W_i = 1 + \frac{4 \times (V_i - V_{min})}{V_{max} - V_{min}}$$

The following example may help to clarify this procedure, where 10 criteria are to be weighted in relative terms. The correspondent matrix 10 x 10 is shown in Table 6, where the criteria A was compared to each of the other criteria (B to J) in line one, the criteria B was compared with the criteria C to J, and so on.

**Table 6: Example of the definition of relative weights of the criteria and sub-criteria**

Criteria	A	B	C	D	E	F	G	H	I	J	$V_i$	$W_i$
A		1	1	0	-1	0	1	1	1	1	5	4,1
B	-1		1	-1	-1	1	1	1	1	1	3	3,7
C	-1	-1		-1	-1	-1	-1	-1	-1	-1	-9	1,0
D	0	1	1		-1	0	1	1	-1	1	3	3,7
E	1	1	1	1		1	1	1	1	1	9	5,0
F	0	-1	1	0	-1		1	0	-1	1	0	3,0
G	-1	-1	1	-1	-1	-1		1	0	-1	-4	2,1
H	-1	-1	1	-1	-1	0	-1		0	-1	-5	1,9
I	-1	-1	1	1	-1	1	0	0		-1	-1	2,8
J	-1	-1	1	-1	-1	-1	1	1	1		-1	2,8

In this example, the criteria D is less important than the criteria E as the value assigned is -1 (interception of line D with column E) and consequently the value of E compared with D is 1 (interception of line E with column D). The values within the dashed triangle are all the symmetric values of those on the right.

The value of each of the criteria is then obtained by summing all values in each of the lines ( $V_i$ ). The highest value obtained is 9 and the lowest -9 and so the most important criterion in this example is the criteria E and the less important is the criteria C. The relative weights ( $W_i$ ), within the scale of 1 to 5, were then obtained using the formula above, rounded to the nearest tenths decimal place.

<sup>5</sup> A good approach to define these relative weights is to ask to as many as possible labour inspectors to fulfill this matrix for each group of criteria and/or sub-criteria to be weighted. The weight of each of these groups would be the average or the median obtained for each of these groups.

# Planning, monitoring and evaluation of an OSH inspection programme

In any country of the world, the number of construction sites running simultaneously is high or very high, depending on the economy, investment in construction and the priorities of the governments.

However, the number of labour inspectors is usually limited, and they often have to deal with many different kinds of workplaces. Moreover, the number of laws and regulations concerning OSH tends to be very high and many of them require specialist knowledge.

This means that priorities have to be set among construction sites that need attention. Some countries have organised groups of labour inspectors specifically to deal with the construction industry<sup>6</sup>. This is indeed highly recommended for all countries with many and complex construction sites.

Planning an OSH inspection is discussed in subsection 5.1, while subsection 5.2 deals with the monitoring and evaluation of an OSH inspection programme.

## 5.1 Planning an OSH inspection programme

An OSH inspection programme aims to make best use of the existing human resources of the labour inspectorates by establishing priorities among the workplaces to inspect. In the construction industry, such a programme should consider the following two groups:

- construction enterprises;
- construction sites.

In both cases, priority should go to the construction enterprises and sites with the highest percentages on the evaluations, meaning those with the highest risk. They should be ranked by those percentages. The percentage above which they should be selected for inspection will depend on the number of labour inspectors and how many cases each of them can inspect.

This percentage hereafter called the “reference percentage” could be used to classify the enterprises and sites in two “classes of risk”:

- “high-risk”, meaning those with evaluations on or above the “reference percentage”;
- “low-risk”, meaning those with evaluations below the “reference percentage”.

The evaluations should be done periodically, updating the information included in the Prior Notices or, preferably, the Final Notices, and their respective annexes. The period between evaluations should be fixed (e.g. 3 years).

However, in view of the high number of construction enterprises and sites, there should be a balance both between inspections of enterprises and inspections of sites, and also within each of those groups, so as to avoid inspecting the same enterprises and sites, while leaving the others without any inspection.

---

<sup>6</sup> The number of labour inspectors dealing specifically with the construction industry per each thousand construction sites could be a good indicator to explore (e.g. comparing it with the OSH accident statistics).



A percentage (e.g. 25%) should be set for random inspections among enterprises and sites not included in the group with the highest percentages on the evaluations (“low risk” enterprises and sites).

Because most occupational accidents occur on construction sites, inspecting them should take priority over inspecting construction enterprises, unless a single enterprise has many “high-risk” sites. In the latter case, it may be more efficient to inspect the enterprise to evaluate the general procedures that it follows on its construction sites. A proportion of construction enterprises relative to sites to be inspected should be set (e.g. 20%).

The time needed for a full inspection will depend on size and complexity, but also on the construction expertise of the labour inspectors. However, except in particular cases, there is no need to inspect all the activities of a construction enterprise or site. In general, on-site inspections should cover only some areas or activities of the enterprise or site and the report should reflect this. It is better to focus on some issues in depth than on many issues in a superficial way, all the more so when the existing resources of the labour inspectorates are, as usual, limited.

If, for example, each labour inspector takes one day to inspect a construction enterprise or site and another day to prepare the corresponding report, then about 10 cases should be inspected each month by each labour inspector<sup>7</sup>, say 2 construction enterprises and 8 construction sites (considering a distribution 20% and 80% for inspections to enterprises and to sites). Of those 2 construction enterprises to be inspected, say 0,5 (25% x 2, i.e., 1 enterprise every 2 month per labour inspector or 1 enterprise every month per two labour inspectors) should be enterprises classified as “low-risk” and of the 8 construction sites to be inspected, 2 should be sites not among those with the highest percentages on the evaluation.

This example is illustrated in Figure 13, which shows the distribution of a two-monthly inspections of construction enterprises (20%) and construction sites (80%). In both cases, they are separated by those with “high-risk” (meaning those with the highest percentages on the evaluations, e.g.,  $E = 75\%$ ) and those with “low-risk” (meaning those with lower percentages on the evaluations, e.g.,  $E < 75\%$ ).

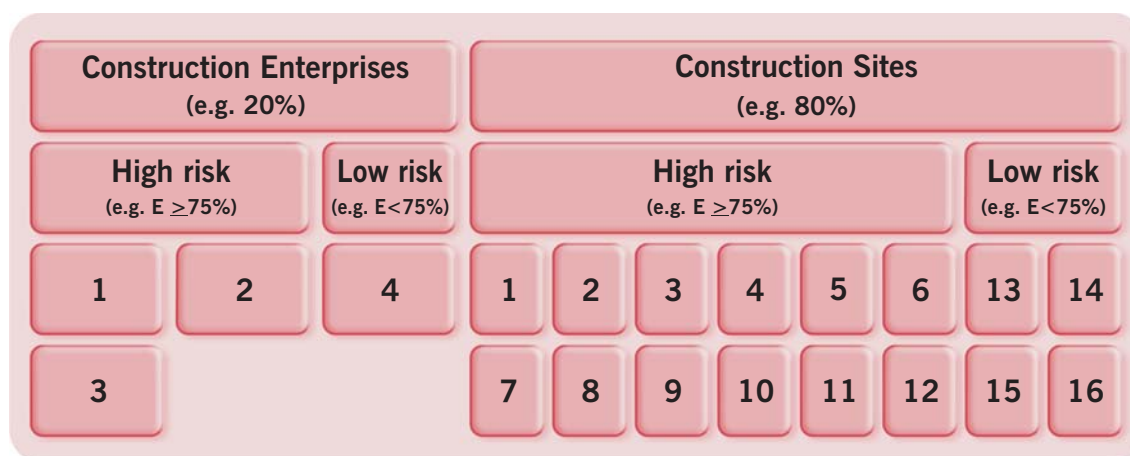

Figure 13 – Example of the distribution of two-monthly inspections

The inspections should be performed in a systematic way, using the instruments and methodologies described in Section 9 of this document.

<sup>7</sup> In this example, the labour inspectors are involved at full-time to inspections of construction enterprises and sites and they have the knowledge and experience on this industry, i.e. the number of cases refers to the equivalent to full-time labour inspectors in the activity of construction inspection. The actual number of cases to be inspected by each labour inspector should be therefore reduced according to the percentage of time effectively spent on the activity of inspection. Other activities may include, for example, general administrative tasks, attendance to training programmes, investigation of occupational accidents, etc. (sometimes these activities may achieve more than 30% of the available time of each labour inspector).

Assuming these figures, if the number of “high-risk” enterprises and sites to inspect is 35 and 100, respectively (taking a group of enterprises and sites evaluated according to the methods described in subsections 42 and 43 above), the number of labour inspectors needed to perform all these inspections during one month should be 18, i.e. 135 cases/(1-25%)/10 cases/labour inspector.

## 5.2 Monitoring and evaluation of an OSH inspection programme

The OSH inspection programme should be monitored and evaluated through periodic reports: monthly, three-monthly and yearly (Figure 14).

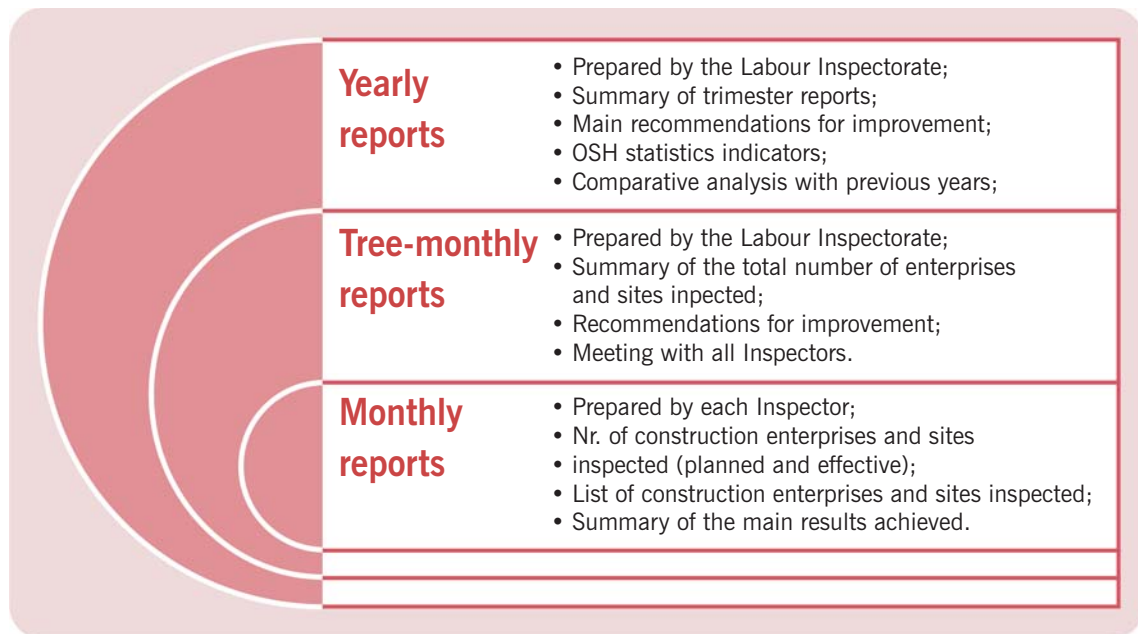

Figure 14 – Control and evaluation of an OSH inspection program

The monthly reports should be prepared by the labour inspectors. They should include the following information:

- number of (high and low risk) construction enterprises and (high and low risk) construction sites planned to be inspected and those that were actually inspected during the month and, if they were not actually inspected, the reasons why not;
- list of construction enterprises inspected and their relevant details (name, address, date of the inspection, reasons why the enterprise was selected for inspection, turnover, number of workers, number of accidents reported and OSH statistics indicators for the previous year, number of cases as per each of the enforcement instruments referred to in Section 9, and other relevant information);
- list of construction sites inspected and their relevant details (name address, date of the inspection, reasons why the site was selected for inspection, project budget, number of workers on the day of the inspection, number of accidents reported since the opening of the site, number of cases as per each of the enforcement instruments referred to in Section 9, and other relevant information);
- summary of the main results achieved, difficulties encountered in performing the inspections, recommendations for continuous improvement of the OSH inspection report (especially the inspection methods).



The three-monthly reports should be prepared by the person responsible at the labour inspectorate, using the monthly reports prepared by each labour inspector under his/her supervision (at the delegation / geographic area level). This report should summarise the main issues, the total number of construction enterprises and sites inspected, total turnover of all enterprises inspected, total number of workers, etc., including the main recommendations for improvement. During the following month, a meeting involving all the labour inspectors should be held to discuss this report, exchange information about the methods used during the inspections, including the situations where each of the enforcement instruments was or should have been used, and other relevant issues.

The yearly report should be prepared during the first three months of every year by the person responsible at the labour inspectorate (at the delegation/geographic area and national levels), summarising the information contained in the three-monthly reports, including the main recommendations, comparison with previous reports, the evolution of the main OSH statistics, namely, frequency rate, incidence rate, severity rate and the days lost per new case of occupational injury. This report should also be included in the yearly report that national labour inspectorates usually prepare for external use and public consultation.

# OSH organization of the construction enterprises and sites, including management of subcontractors

Occupational safety and health in the construction industry is highly dependent on the human resources involved, their expertise and their organisation, i.e. on the way the relationships among them are established and the functions detailed. These issues are presented in subsection 6.1.

On the other hand, the construction enterprises and sites are more and more management and coordination organisations, whose actual work is mostly performed by chains of subcontractors. This brings out the importance of the management of subcontractors, an issue that is addressed in subsection 6.2.

## 6.1 OSH organisation of construction enterprises and sites

Construction enterprises may be classified, by the number of workers employed, as (Table 7): micro (fewer than 10 workers), small (10 to 49 workers), medium (50 to 249 workers) and large (250 or more workers). This is the classification used in the European Union, but individual countries may use other classifications. In many countries, the average number of workers per construction enterprise is estimated at 5 or 6.

**Table 7: Classification of construction enterprises by the number of workers employed**

Classification	Nr. of workers employed
Micro	< 10 workers
Small	10 to 49 workers
Medium	50 to 249 workers
Large	≥ 250 workers

On the other hand, although the number of construction sites is very high in many countries, only a few are large construction sites (employing 250 or more workers). Micro and small construction sites predominate in most countries.

The OSH organisation of construction enterprises and sites should take this into account and equip their organisations with the technical resources needed to ensure that safety and health measures are implemented. These resources should be appropriate for the working environment and the potential hazards/risks involved. There is a difference between resources needed for construction enterprises and those needed for construction sites.

In many countries, the law requires enterprises to organise in-house or external OSH services depending on the number of workers employed in each workplace (meaning each building and/or group of buildings all together in a small area). In some countries, construction enterprises must organise in-house OSH services at each workplace where there are 50 or more workers.

The OSH experts to be involved in the OSH organisation will depend on the size, complexity and specific hazards/risks in each workplace. For example, the requirements for the OSH experts, in terms





of their number and qualifications, for a chemical plant will certainly be different from those required for an office block.

This principle also applies to the OSH organization of construction sites: the specific hazards/risks involved and the measures to be implemented require specialist knowledge of the construction process. The number and expertise of the OSH experts to be involved on a construction site will thus depend on the size of the construction site as well as the number, complexity and type of construction works running at the same time. It is difficult to establish a general rule, but every construction site should have at least one OSH expert, in-house (i.e. full-time) or external (part-time) on the construction site.

## 6.2 Management of subcontractors

For some years, construction enterprises (especially medium and large ones) have been moving from a traditional system of management of basic resources (labour, materials, equipment) to a system of management of subcontractors, i.e. from a system where most actual works were performed in-house using the enterprise's own resources to a system where most or even all of the actual works are done by subcontractors (based on work performed, labour-only subcontracting or other). In other words, outsourcing in the construction industry is now in command, as it offers flexibility concerning labour needs.

Enterprises can take on more construction projects when the economy is doing well and reduce the number in periods of recession without being committed to keeping their employees on. They increasingly manage and coordinate other enterprises rather than doing actual construction.

In many countries, about 85% of the workers on construction sites are subcontractors' workers. The subcontracting chain may have 5 levels or even more.

The number of temporary workers is estimated to be more than 60% in many countries and the number of daily hours of work may exceed ten, often with a six-day week or even more. Moreover, about 95% of the severe accidents involve subcontractors' workers. Figure 15 summarises this (ILO, 2001b).

The growing tendency for subcontracting (in special, labour-only subcontracting, self-employment, etc.) is a reality that countries have to live with and deal with.

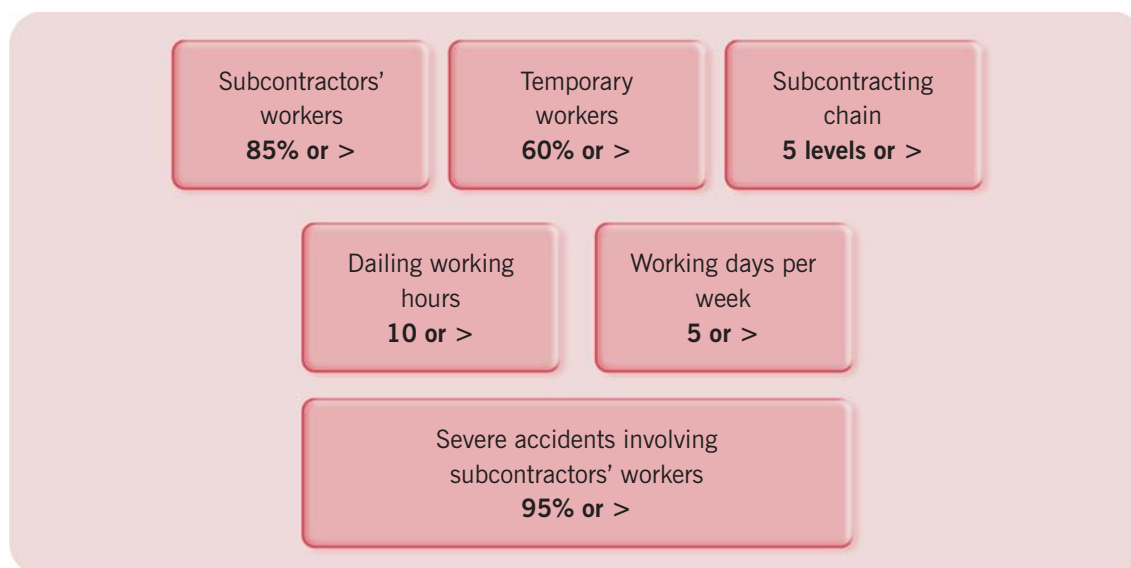

Figure 15 – Some facts on subcontracting in the construction industry

However, the subcontracting practices raise other issues that may compromise the safety and health of construction workers. In many countries the government and the social partners have been discussing such issues. The issues include:

- OSH training programmes for the workers (in different languages following the globalisation of the economy);
- information on risks that the workers face;
- supplying collective and personal protective equipment;
- health monitoring for all workers;
- occupational accident insurance.

In many countries, the national laws and regulations attribute these and many other responsibilities to the employer, i.e. the person who contracted the worker. Although this works well in many situations (and industries), in the construction industry there are many cases that need more attention and clarification.

For example, when a contractor (or a subcontractor in the chain) uses labour-only subcontracting, the employer is indeed this labour-only subcontractor, and usually does not know the work their employees will do on the construction site and so is not able to identify the specific needs for training, information related to risks and safety equipment. In these cases, these labour-only enterprises are in fact employers but they do not coordinate the tasks of their employees. The solution is to clarify these issues in the contracts between the enterprises involved (contractor and labour-only contractor).

Accordingly, a question that has been discussed in many countries is: Should subcontracting be limited or controlled? A positive answer has been given to both, i.e., subcontracting has been both limited and controlled (Figure 16). However, introducing limitations to subcontracting is against the free market between private companies.

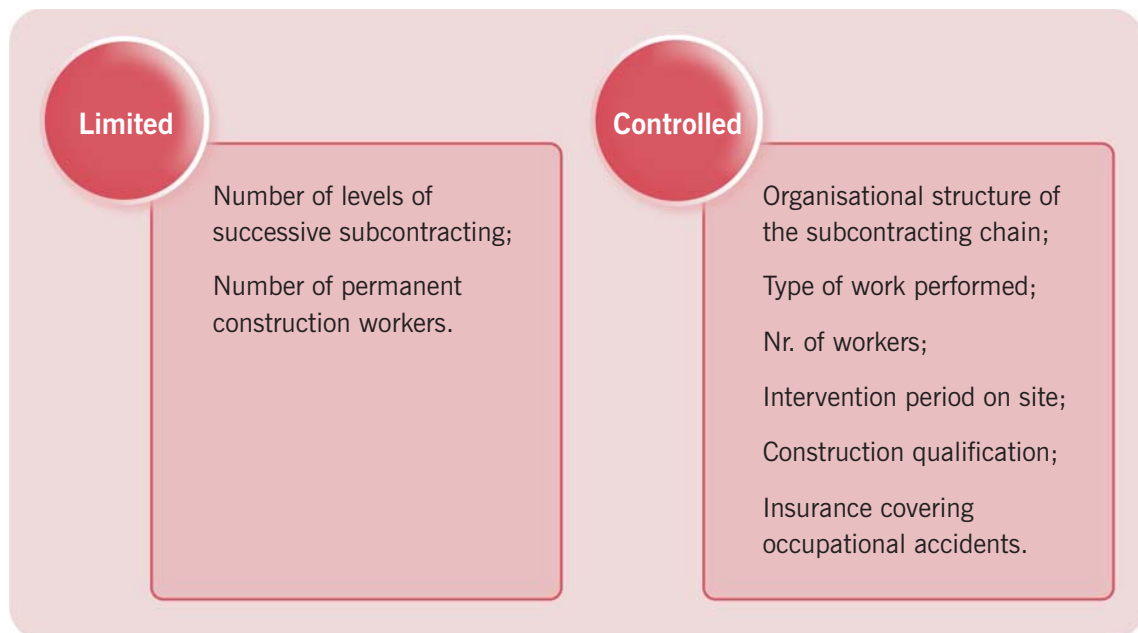

Figure 16 – Subcontracting: limited and controlled

The limitations have been implemented in some countries on subcontracting chain, e.g. limiting it to 3 levels, with the first level being the subcontractor of the constructor or the main constructor. This is being done through the requirements in the safety and health plans for specific construction projects (usually large ones). Some countries are introducing this limitation into their national laws or regulations especially for the construction industry. On every construction site, the contractors should keep and maintain a record of all subcontractors.



Other limitations have also been set, such as a minimum number of permanent construction workers that a construction firm may employ. Many countries have already made this a condition for qualifying to become constructors instead of just contractors. In other countries, it has been introduced by a specific OSH-related law (e.g. 30%). Where this limitation is used, this percentage should be applied not only at the construction enterprise level, but also at the construction site level to avoid the concentration of the permanent workers in the same construction site, leaving other construction sites without any or just a few of them.

Independently of such limitations, the control of the successive chain of subcontracting should be always required on all construction sites (small or large) and records should be kept and maintained by the main constructor or by each constructor (if more than one constructor has a contract with the owner/client of the project). The labour inspectorate may at any time inspect the accuracy of these records.

Moreover, each employer should also keep the same records for their subcontracting chain, ready to be inspected at any time by the contractor who subcontracted him and also by the labour inspectorate, when necessary or when questions arise from inspection of those records by the main constructor or constructors.

At the construction site level, there are many ways to organise this monitoring of the subcontracting chain. A simple way to do this is through a form like the one in Figure 17, which lists all contractors and subcontractors involved in the construction site.

**CONTROL OF SUBCONTRACTORS AND SUBCONTRACTING CHAIN**

Number: \_\_\_\_\_ Page: \_\_\_\_\_

Construction site: \_\_\_\_\_ Code: \_\_\_\_\_

Owner: \_\_\_\_\_ Safety expert: \_\_\_\_\_

Supervisor: \_\_\_\_\_ Contractor: \_\_\_\_\_

**This form includes:**  Constructor and all their subcontractors;  Sub-constructors and all their subcontractors;  Only constructors;  
 Only sub-constructors;  Labour-only subcontractors;  Equipment-only subcontractors with or without operator; Year: \_\_\_\_\_ Month: \_\_\_\_\_  
 Other ( \_\_\_\_\_ )

Ref.	Employer	Resp. of the Employer	Type of work performed	Nr. of workers			Intervention period		Construction qualification (according to the law)					
				PW	TW	%PW	Start date	End date						

Prepared by: \_\_\_\_\_ Verified by: \_\_\_\_\_ Approved by: \_\_\_\_\_

Notes: (1) The reference to the employer must be referred by levels, considering for the constructors the sequence of natural numbers (1, 2, 3, ...), the first sublevel of subcontractors as 1.1, 1.2, 2.1, 2.2, etc., the second sublevel as 1.1.1, 1.1.2, etc. and successively (e.g. the reference to an employer as 1.2.3, means the subcontractor 3 of the subcontractor 2 of the constructor 1); (2) The 3rd column refers to the person of the employer's responsible on this site; (3) The 4th column refers to the number of permanent workers (PW) and the temporary workers (TW) and the percentage PW/(PW+TW); (4) The end date of the intervention should be recorded after the employer has ended his work on this site; (5) The construction qualification of each employer depends on the national law of each country and it applies, in special, to the constructors and not necessarily to the other subcontractors; this qualification specifies usually the type of works the employer may perform. Where applicable, the official document stating the construction qualification should be attached to this form.

Figure 17 – Control of subcontractors and subcontracting chain

In this form, the following applies:

- The reference to the employer should be referenced by levels, considering for the constructors the sequence of natural numbers (1, 2, 3, ...), the first sublevel of subcontractors as 1.1, 1.2, 2.1, 2.2, etc., the second sublevel as 1.1.1, 1.1.2, etc. (e.g. the reference to an employer as 1.2.3, means the subcontractor 3 of the subcontractor 2 of the constructor 1);
- The third column refers to the person on site representing the employer;
- The fourth column refers to the number of permanent workers (PW) and temporary workers (TW) and the percentage PW/(PW+TW);



- The start and end dates of the intervention period on site of each employer;
- The construction qualification of each employer depends on the national law of each country and it applies, in special, to the constructors and sub-constructors; this qualification specifies usually the type of works the employer may perform. Where applicable, the official document stating the construction qualification should be attached to this form.

The following Figure 18 may also be used as a complement of the previous one, giving a better idea through a flow chart of “who subcontracted whom”.

	<b>ORGANISATIONAL STRUCTURE OF THE SUBCONTRACTING CHAIN</b>	Number: _____	Page: _____
	Construction site:		
	Owner:		
	Contractor:		

(where applicable, reference number linking to the previous form)

Name of the Constructor (or the Subcontractor / Sub-subcontractor / ... etc.) depending on the level under consideration

Name of the subcontractor / sub-subcontractor/ ... 1	1
Name of the subcontractor / sub-subcontractor/ ... 2	2
Name of the subcontractor / sub-subcontractor/ ... 3	3
Name of the subcontractor / sub-subcontractor/ ... 4	4
Name of the subcontractor / sub-subcontractor/ ... 5	5
Name of the subcontractor / sub-subcontractor/ ... 6	6
Name of the subcontractor / sub-subcontractor/ ... 7	7
Name of the subcontractor / sub-subcontractor/ ... 8	8
Name of the subcontractor / sub-subcontractor/ ... 9	9
Name of the subcontractor / sub-subcontractor/ ... 10	10

(where needed, reference number linking to the next form)

Figure 18 – Flow chart of the subcontracting chain

Whatever the process or form used, the important thing is to monitor all the issues above, and to take into account the laws, regulations and construction practice in each country.



It is also important to check the insurance against occupational accidents of the workers of each of the employers in the chain, including the self-employed workers. A sample form is shown in Figure 19.

Figure 19 – Form for controlling of the insurance covering the occupational accidents

In this form, the following applies:

- the reference (Ref.) to the employer should be the same than the one referred in Figure 18, in view to facilitate the monitoring process in both forms;
- the intervention (INT.) may be referred as C (constructor), SB (sub-Constructor), SC (subcontractor who is not a constructor), SW (Self-employed worker); other situations may also be used to respond to specific needs (e.g. a more detailed specification of these different stakeholders);
- the insurance modality may be referred to as FP-WN (fixed premium with names), FP-NN (fixed premium without names), VP (variable premium); in each country these types of insurance modalities need to be adapted to accommodate the country's insurance system;
- the coverage may be referred as Ad (adequate) or N-Ad (Non adequate); this refers to the type of construction works covered in view of the different levels of risks of construction projects, i.e., for example, the insurance premium for a building is usually different from that for a bridge.

# OSH hazards/risks on construction sites

The general principle for minimizing OSH hazards/risks is:

to identify/know the hazards/risks involved, to analyse them and consequently avoid or prevent them.

This principle should be applied to each of the basic resources (labour, material and equipment) and to each construction operation, construction element and construction project as a whole. In many countries (e.g. the European Union countries), this procedure is known as the application of the “general principles of prevention” during the design phase and during the execution phase. These principles are presented and briefly described with examples in subsection 7.1 of this document.

It is important to know the main occupational safety and health hazards/risks in the construction industry and these are presented in subsection 7.2. This will allow all those who have to take the preventive measures (those involved directly in the construction process) or to inspect the measures taken (labour inspectors, but also the OSH experts on behalf of other interested parties), to pay special attention and give priority to these hazards/risks.

## 7.1 General principles of prevention

In the European Union, the nine “General Principles of Prevention” (GPP) are: (1) Avoid risks; (2) Evaluate the risks which cannot be avoided; (3) Combat the risks at source; (4) Adapt the work to the individual, especially as regards the design of work places, the choice of work equipment and the choice of working and production methods, with a view, in particular, to alleviating monotonous work and work at a predetermined work-rate and to reducing their effect on health; (5) Adapt to technical progress; (6) Replace the dangerous by the non-dangerous or the less dangerous; (7) Develop a coherent overall prevention policy which covers technology, organization of work, working conditions, social relationships and the influence of factors related to the working environment; (8) Give collective protective measures priority over individual protective measures; (9) Give appropriate instructions to the workers.

These are also shown in table 8 together with some comments on or examples of each. Compliance with these GPP is of utmost importance for safety and health during the design and construction phases. They should be applied by the designers during the design process and by the contractors during the construction process, and be followed up by those who have to monitor the prevention measures (project supervisors, OSH coordinators and experts, etc.).



**Table 8: The nine General Principles of Prevention**

1. <i>Avoid risks</i>	To avoid risks of falls on a building project, consider the execution of scaffolding as the building grows in height; consider planning the project by avoiding simultaneous and incompatible construction operations (worker distractions are responsible for many occupational accidents); carefully consider the appropriate period of time to be allotted for the performance of the different tasks to minimize the pressure that might otherwise accompany an unrealistic work goal; ...
2. <i>Evaluate the risks which cannot be avoided</i>	Consider the preparation of Inspection and Monitoring Plans for all relevant construction operations in terms of risks involved; consider the technical maintenance, pre-commissioning checks and regular checks on installations and equipment with the objective of correcting any faults which might affect the safety and health of workers; ...
3. <i>Combat the risks at source</i>	Consider ways of confining and neutralizing the risk at the source; avoid the use of noisy equipment by selecting equipment that has been engineered to generate less noise; consider also the sound-proofing of the engine 's compartment; consider air conditioning in the driver compartment on earthmoving equipment so that the work can be performed with closed windows without exposing the driver to noise and other environmental hazards as dust and fumes; ...
4. <i>Adapt the work to the individual, especially as regards the design of work places, the choice of work equipment and the choice of working and production methods, with a view, in particular, to alleviating monotonous work and work at a predetermined work-rate and to reducing their effect on health</i>	To reduce hazards consider the use of ergonomic equipment and perform risk analysis when choosing equipment and construction processes and methods; avoid undue pressure in project scheduling, by accurately allotting adequate time to perform each construction operation; perform regular health inspections of workers; ...
5. <i>Adapt to technical progress</i>	Use only certificated equipment according to the regulations and standards; prepare a procedure to organize a database on all relevant regulations and standards and keep the database current by including all recent changes; implement the procedures to avoid the non intentional use of obsolete technical documents; ...
6. <i>Replace the dangerous by the non-dangerous or the less dangerous</i>	Reduce hazards by using vegetal based oil for forms instead of dangerous oils; replace materials based on dangerous asbestos with other equivalent and non dangerous materials; be aware of the conditions under which the hazardous materials are to be removed (e.g. existing dangerous asbestos); consider the demarcation and laying-out of areas for the storage of various materials, in particular where dangerous materials or substances are concerned; plan the storage and disposal or removal of waste and debris; ...
7. <i>Develop a coherent overall prevention policy which covers technology, organization of work, working conditions, social relationships and the influence of factors related to the working environment</i>	Consider a formal safety and health (prevention) policy provided by each Contractor on site; assure the cooperation between employers and self-employed persons; consider the interaction with industrial activities at the place within which or in the vicinity of which the construction site is located; choose the location of workstations bearing in mind how access to these workplaces is obtained, and determine ways or areas for the passage and movement of equipment; keep the construction site in good order and in a satisfactory state of cleanliness; consider the conditions under which various materials are handled; implement periodic safety and health audits and inspections; ...
8. <i>Give collective protective measures priority over individual protective measures</i>	Consider, for example, guardrails for fall protection, where needed, and complementary safety nets and/or life lines with safety harnesses (together with all other personal protective equipment that are mandatory, including hardhats and safety shoes); use the appropriate shoring systems or slope the walls of excavations, whenever the soil is not pure rock; ...
9. <i>Give appropriate instructions to the workers</i>	Instructions should be simple and only as detailed as needed; consider visual communications; consider different languages for these instructions according to the origin of workers on site, and promote safety and health meetings; ...

In some cases, the GPP should be included in the specifications as mandatory, so that all designers and contractors will follow them in the tendering processes. These stakeholders must know, understand and interpret these principles in the light of the design and the construction process and working methods for each project.

In general terms, the application of these general principles of prevention, during both design and execution phases, is based on the following question for each construction project and each major construction element (taking into consideration different possible or alternative architectural, technical or organizational solutions):



### How will it be built and maintained?

For each construction project (a building, a bridge, a road, etc.), this question can be expanded in different ways as in the following examples:

- How will each construction element be built without putting workers into a dangerous situation that might compromise their safety and health? Is there any other solution which is less dangerous and does not compromise the architectural or technical requirements?
- How will this construction element be maintained during the life of the construction project, without putting the maintenance workers at risk? How will the façade be cleaned (for example, windows may be cleaned from the inside or should a platform be installed on the outside)?
- How will maintenance workers get access to equipment if it is placed in a particular position (for example, air conditioning equipment placed very high)?
- How will access be provided to the roof of the building (bearing in mind the slope as well)? For future maintenance, should some points of anchorage be left in place to accommodate “life lines” and safety harnesses, or to attach platforms on the ridge of the roof? Could the parapet on the roof be 1,00 - 1,20 metres high to avoid the need for temporary guardrails (ensuring that the workers of both the execution and maintenance phases work safely on the roof)?

These are just some of the questions that should be always kept in mind, especially by designers, contractors and their OSH experts, as well as by the project supervisors and the OSH experts/coordinators appointed by the owner of the construction project (during both the design and execution phases).

OSH concerns the whole life of the construction project (from the very early stages of design until the demolition). Accordingly, the Safety and Health Plan deals with the OSH of the workers involved during the execution phase and the Safety and Health File deals with the OSH of the workers involved during the maintenance period (both documents are referred to in subsection 9.1).

OSH should be guaranteed in all construction projects, but the requirements should take into account their size (based on estimated project cost and/or person-days), complexity and whether the works involve particular risks as defined in the law of many countries.

Types of work involving particular risks as defined by the Construction Sites Directive (92/57/EC, 1992) of the European Union are: (1) Work which puts workers at risk of burial under earth falls, engulfment in swampland or falling from a height, where the risk is particularly aggravated by the nature of the work or processes used or by the environment at the place of work or site; (2) Work which puts workers at risk from chemical or biological substances constituting a particular danger to the safety and health of workers or involving a legal requirement for health monitoring; (3) Work with ionizing radiation requiring the designation of controlled or supervised areas; (4) Work near high voltage power lines; (5) Work exposing workers to the risk of drowning; (6) Work on wells, underground earthworks and tunnels; (7) Work carried out by drivers having a system of air supply; (8) Work carried out by workers in caisson with a compressed-air atmosphere; (9) Work involving the use of explosives; (10) Work involving the assembly or dismantling of heavy prefabricated components.

However, related to the first group of works involving particular risks referred to in above, it does not seem reasonable, for example, to consider as “involving particular risks” all risks of falling independently of the working height or all excavations independently of the working depth.

Actually, the mentioned EU Directive gives each country the option of setting figures for individual situations and indeed some countries have taken it up. For risk of burial under earth falls, some countries consider a depth of more than 1,20 metres while others consider 1,50 metres. As for the risk of falling from height, some figures set this at 2 metres, some at 3 metres or at 5 metres.

Some countries again have set figures for other work involving particular risk, as for example the demolition or deconstruction work involving more than 200 cubic metres of the product to be removed from the construction site, and work involving lifting equipment with a capacity over 60 tons-meter (e.g. mobile or tower cranes).



## 7.2 The main OSH hazards/risks in the construction industry

The most frequent hazards/risks in the construction industry fall into two main categories (Figure 20):

- hazards/risks that may cause occupational accidents, sometimes fatal, immediately or soon after they occur;
- hazards/risks that may cause occupational illness, sometimes also fatal, in the medium or long term (from a few hours to many years later).

The leading accident hazards/risks in the construction industry in most countries are:

- Falls from height (from unguarded floors, platforms, scaffoldings, roofs, etc.);
- Caught in/between (malfunction of machinery, etc.);
- Cave in (malfunction of the shoring system, sloping missing in excavations, etc.);
- Electrocution (by contact with power lines, power tools, etc.); and
- Struck by (falling objects, etc.).

The leading occupational illnesses hazards/risks in the construction industry in most countries are:

- Back injuries (from carrying heavy loads, working in inappropriate positions, etc.);
- Respiratory diseases (from inhaling dust, fumes, etc.);
- Musculoskeletal disorders (from sprains and strains of the muscles, injuries affecting the hand and wrist, the shoulders, neck and upper back, the knees, etc.);
- Hearing losses (from long time exposure to noise); and
- Skin diseases (manipulation of dangerous materials, exposure to the ultraviolet rays).

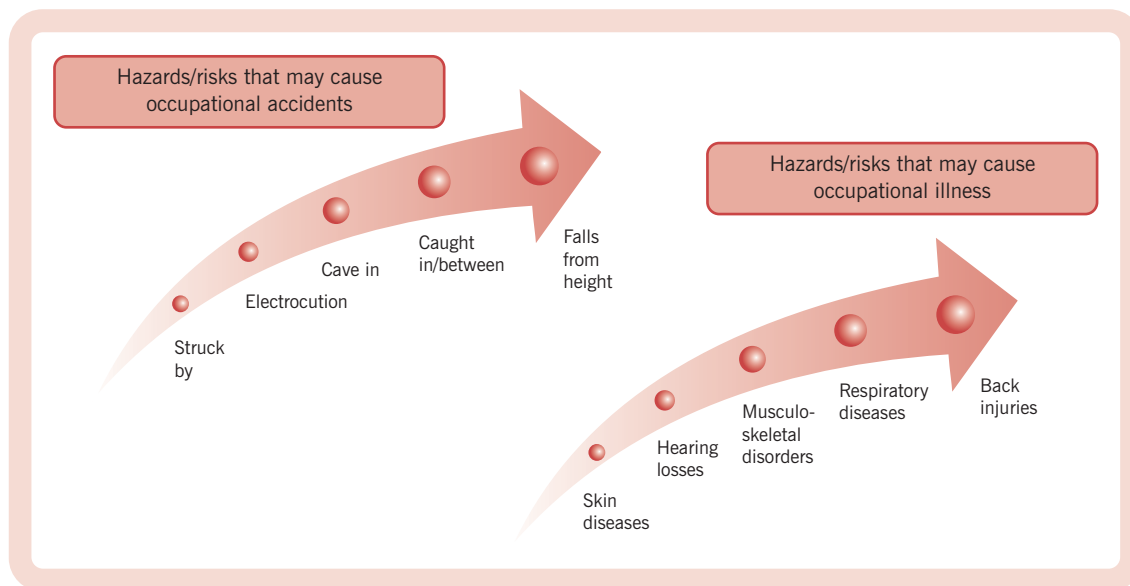

Figure 20 – Most frequent hazards/risks in the construction industry

Many other potential hazards/risks in the construction industry depend on the type of construction works (buildings, bridges, etc.). Table 9 gives a non-exhaustive list of hazards/risks in the construction industry. It can be used to identify and record the main hazards/risks that may occur in a specific construction project by checking “yes”, “no” or “NA” (not applicable). It may also be used to record the risk level (RL) by estimating a probability (P) of occurrence and a severity (S).

**Table 9: Identification of hazards and risks of a construction project/site**

Construction project/site:							Ref./Date
Hazards/Risks	Exists?			Risk Level (RL)			Notes / Comments (e.g. where the risks may occur, exposure period, temperature, etc.)
	Yes	No	NA	P	S	RL	
<b>1. Mechanical</b>							
1.1. Falls from height							
1.2. Falls at the same level							
1.3. Fall of objects							
1.4. Struck between							
1.5. Cave in							
1.6. Running over							
1.7. Collision of vehicles							
1.8. Explosion							
1.9. Crushing of the foot							
1.10. Fall for slipping							
1.11. Pointed or cutting objects							
1.12. Foot torsion (irregular floor)							
1.13. Shock at the malleolus level							
1.14. Shock at the metatarsus level							
1.15. Shock at the leg level							
1.16. Shock with fixed objects							
1.17. Vibrations							
1.18. Hits on the head							
1.19. Sting							
1.20. Cuts							
1.21. Friction							
1.22. Hold by rotary parts							
1.23. Pinch							
1.24. Fragments							
1.25. Perforations							
1.26. Free							
<b>2. Electrical</b>							
2.1. Electric shock							
2.2. Electrostatic discharges							
2.3. Free							
<b>3. Thermal</b>							
3.1. Heat							
3.2. Cold							
3.3. Flame							
3.4. Fire							
3.5. Projection of metals in fusing							
3.6. Free							
<b>4. Radiations</b>							
4.1. Ultraviolet radiations							
4.2. Radiations infra-red ray							
4.3. Solar radiations							
4.4. Ionizing radiations							



Construction project/site:							Ref./Date
Hazards/Risks	Exists?			Risk Level (RL)			Notes / Comments (e.g. where the risks may occur, exposure period, temperature, etc.)
	Yes	No	NA	P	S	RL	
4.5. Laser rays							
4.6. Contamination							
4.7. Free							
<b>5. Noise</b>							
5.1. Exposure to noise							
5.2. Free							
<b>6. Chemical</b>							
6.1. Dust							
6.2. Fumes							
6.3. Gases or vapours							
6.4. Toxic or corrosive products							
6.5. Corrosive liquids							
6.6. Acid							
6.7. Solvent							
6.8. Free							
<b>7. Biological</b>							
7.1. Pathogenic material							
7.2. Fungus							
7.3. Free							
<b>8. Other hazards/risks</b>							
8.1. Humidity							
8.2. Intemperate weather							
8.3. Confined space							
8.4. Low visibility							
8.5. Free							
8.6. Free							
8.7. Free							
8.8. Free							
8.9. Free							
8.10. Free							
<b>9. Hazards/risks affecting health</b>							
9.1. Back injuries							
9.2. Respiratory diseases							
9.3. Musculoskeletal disorders							
9.4. Hearing losses							
9.5. Skin diseases							
9.6. Dermatitis							
9.7. Carcinoma							
9.8. Intoxication							
9.9. Free							
9.10. Free							



## OSH control measures on construction sites

The increasing competition among the construction enterprises emphasizes the need to pay more attention to construction productivity issues. In view of this, it is important to manage the basic resources of labour, materials, equipment and money in an efficient way. Taken together, the management of these resources aims to perform the various operations of each element<sup>8</sup> of the construction project (Figure 21).

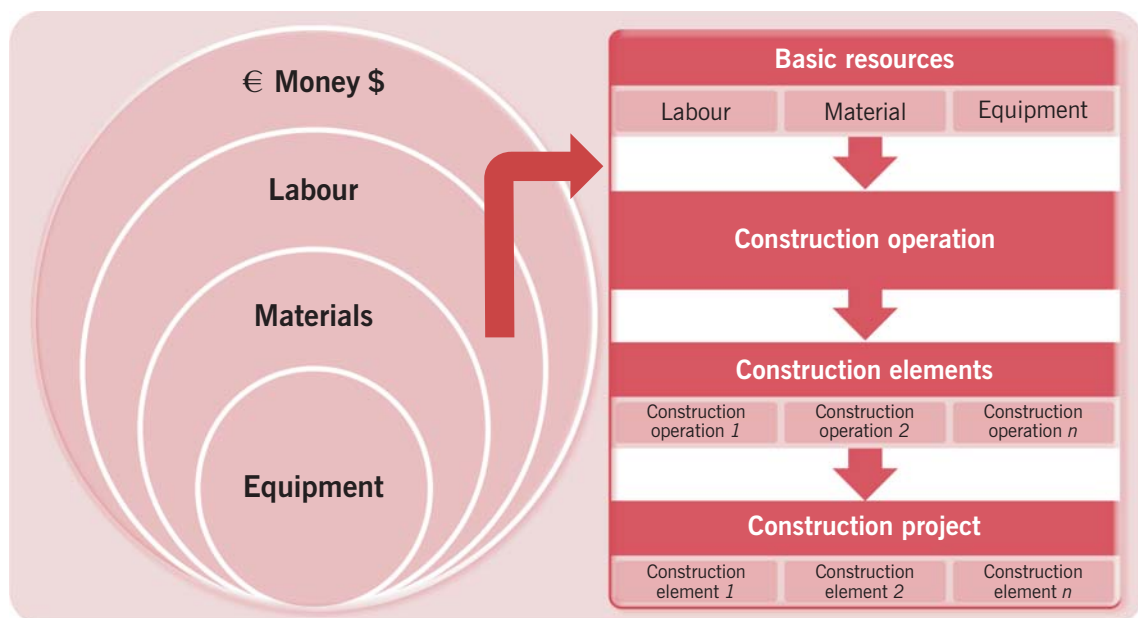

Figure 21 - The management of construction projects and their resources

The optimization of the construction process to achieve quality, environment, safety and health, cost and time objectives is complex and lies beyond the scope of this document.

Nevertheless, more and more construction professionals recognise that occupational safety and health on construction sites plays an important role in achieving these objectives.

Independently of this “economic” view of the issue, continuous improvement of the working conditions should never be overlooked. Workers must be kept alive, but healthy as well, at any “cost”.

To ensure a safe and healthy construction site, it is very important to control each of the basic resources of the construction operations and elements, and of the construction site as a whole. That is the objective of this section. In subsections 8.1 to 8.3 the main controls are presented.

<sup>8</sup> A construction element is each part of the construction project as piles, columns, façade, covering, etc. that may include a group of construction operations. For example, a column of reinforced concrete may have at least 3 construction operations: reinforcement, form and concreting.



These controls should be carried out by the constructor or constructors (while employers according to the OSH laws and regulations of each country), who should ensure their application by each of the subcontractors.

While these controls are assigned to the constructors, they are also very useful for those who have the duty of inspecting their application, namely OSH experts (appointed by those involved in the construction process – owner, contractors, etc.), labour inspectors and other persons with the duty to undertake the same mission (e.g. in some countries, the OSH controllers who monitor the insurance premium covering the occupational accidents and/or diseases).

## 8.1 OSH control measures related to the basic resources

In this sub-section the OSH measures related to labour, materials and support equipment are presented, respectively, in a), b) and c).

### a) OSH control measures related to labour

The laws and regulations of most countries establish the rules and conditions for the use of personal protection equipment (PPE). PPE is any equipment or accessory to be used by a single worker for protection against potential hazards/risks that may endanger his/her safety and health while performing the tasks assigned to him/her.

The PPE should be used by the worker whenever the hazards/risks cannot be avoided in a satisfactory way by collective protection or through measures, methods or processes of better organisation of the working environment. The PPE may also be used as a complementary prevention measure.

The PPE may be:

- for permanent use; or
- for temporary use.

PPE for permanent use are those that all workers should wear during all the time (e.g. hardhats, safety shoes). PPE for temporary use are those that depends on the tasks assigned (e.g. harnesses to prevent falls from height) and on the working environment (e.g. a noisy environment). Table 10 gives a non exhaustive list of PPE in relation with the part of the body to be protected.

**Table 10: Examples of Personal Protective Equipment**

Part of the body to protect	Personal Protective Equipment
<b>HEAD</b>	Protective helmets; Scalp protection; ...
<b>EARS</b>	Earplugs; Full acoustic helmets; Earmuffs; Ear protection with intercom equipment; ...
<b>EYES AND FACE</b>	Spectacles; Goggles; Face shields; Arc-welding masks and helmets; ...
<b>RESPIRATORY</b>	Filter devices (dust, gas); Insulating appliances with air supply; ...
<b>HANDS AND ARMS</b>	Gloves to protect mechanical hazards; Gloves to protect chemical hazards; Gloves for electricians and heat protection; Over-sleeves; Wrist protection for heavy work; ...
<b>SKIN</b>	Barrier creams/ointments; ...
<b>TRUNK AND ABDOMEN</b>	Waistcoats, jackets and aprons for mechanical hazards; Waistcoats, jackets and aprons for chemical hazards; Body belts; ...
<b>FEET AND LEGS</b>	Safety shoes or boots; Shoes with protective toe-cap; Heat-resistant shoes, boots and over-boots; Thermal shoes, boots and over-boots; Vibration-resistant shoes, boots and over-boots; Anti-static shoes, boots and over-boots; Insulating shoes, boots and over-boots; Kneepads; Removable soles (heat-proof, pierce-proof, sweat-proof); ...
<b>WHOLE BODY</b>	Safety harness; Clothing to protect mechanical hazards; Clothing to protect from chemicals; Heat-resistant clothing; Thermal clothing; Dust-proof clothing; Fluorescent signalling clothing; Protective coverings; ...

The laws and regulations of each country usually make it a responsibility of the employers to supply the PPE each worker needs to wear, together with information on the hazards/risks they protect against.

The form in 22 may be used for checking this; it includes a declaration by the worker that he/she will keep the PPE in good condition.

The following (and more) should also be done:

- a welcoming brochure for new workers should point out the main hazards/risks, most dangerous areas, permanent PPE, etc.;
- alcohol and drug control;
- OSH information and training (awareness-raising, periodic meetings for specific groups of workers, etc.);
- medical surveillance.





L AD				DISTRIBUTION OF PPE AND INFORMATION ON HAZARDS		Revision	Page:
Owner:							
Project:							
Contractor:							
Name of the Worker (If self-employed worker please tick here <input type="checkbox"/> )				Category		N.º	
Employer: <input type="checkbox"/> Contractor <input type="checkbox"/> Other, incl. self employed (Name: _____)							
Ref.ª	Name of the PPEs	Hazards <sup>(1)</sup>	Reception <sup>(2)</sup>		Final Devolution <sup>(3)</sup>		
			Date: / /	Sign: _____	Date: / /	Sign: _____	
			Date: / /	Sign: _____	Date: / /	Sign: _____	
			Date: / /	Sign: _____	Date: / /	Sign: _____	
			Date: / /	Sign: _____	Date: / /	Sign: _____	
			Date: / /	Sign: _____	Date: / /	Sign: _____	
			Date: / /	Sign: _____	Date: / /	Sign: _____	
			Date: / /	Sign: _____	Date: / /	Sign: _____	
<sup>(1)</sup> Codes according to the table below			<sup>(2)</sup> Date and signature of the worker		<sup>(3)</sup> Date and signature of who receives		
HAZARDS							
1 – Falls from height				11 – Foot crush			
2 – Falls at the same level				12 – Foot torsion			
3 – Falling objects				13 –			
4 – Fall by slippery				14 –			
5 – Caught in/between				15 –			
6 – Cave in				16 –			
7 – Electrocution				17 –			
8 – Blows in the head				18 –			
9 – Cuts				19 –			
10 – Sharp and cutting objects				20 –			
DECLARATION							
I declare that I received the Personal Protective Equipment (PPE) above mentioned and that I have been informed on the hazards they cover. I assume the compromise to use them in a correct way according to the instructions also received, to maintain them in good conditions and to participate to my superior hierarchy all the defects and deficiencies that I know.							
I also declare that I have been informed I am covered by an insurance of occupational accident insurance n. _____ of the Insurance Company _____ in the name of my employer _____							
The worker Sign.: _____				Date: / /			
The responsible for OSH of the Contractor				The Technical Director of the Construction Site			
Date: / / Sign.: _____				Date: / / Sign.: _____			

Figure 22 – Form for recording the distribution of PPE and information on hazards/risks

**b) OSH control measures related to materials**

The use of hazardous materials, products, substances and other related materials or incorporated equipment should be evaluated and controlled, with a view to taking the necessary prevention measures.

Figure 23 illustrates a possible form to check the reception of materials or permanent equipment (i.e. equipment to be included permanently in the project) on the construction site.



<b>L AD</b>	<b>MONITORING MATERIALS AND PERMANENT EQUIPMENT</b>						Revision	Page			
	Construction site: _____						Code: _____				
Owner: _____			Safety Expert: _____								
Supervisor: _____			Contractor: _____								
<b>Material or permanent equipment</b>							Code				
Ref.	Verifications / Tasks	Hazards	Reference Documents	Verifications Method	Corrective/Preventive Actions	Resp.	Inspection Frequency	SP			
Prepared by: _____			Verified by: _____		Approved by: _____						
<b>Records of reception on the construction site</b>											
<b>1</b> Delivery note Nr. _____		<b>2</b> Delivery note Nr. _____		<b>3</b> Delivery note Nr. _____		<b>4</b> Delivery note Nr. _____		<b>5</b> Delivery note Nr. _____		<b>6</b> Delivery note Nr. _____	
<input type="checkbox"/> Conf. <input type="checkbox"/> NC Nr. _____		<input type="checkbox"/> Conf. <input type="checkbox"/> NC Nr. _____		<input type="checkbox"/> Conf. <input type="checkbox"/> NC Nr. _____		<input type="checkbox"/> Conf. <input type="checkbox"/> NC Nr. _____		<input type="checkbox"/> Conf. <input type="checkbox"/> NC Nr. _____		<input type="checkbox"/> Conf. <input type="checkbox"/> NC Nr. _____	
Contractor: _____ Supervisor: _____		Contractor: _____ Supervisor: _____		Contractor: _____ Supervisor: _____		Contractor: _____ Supervisor: _____		Contractor: _____ Supervisor: _____		Contractor: _____ Supervisor: _____	

Figure 23 – Form for monitoring materials and permanent equipment

**c) OSH control measures related to support equipment**

On many construction sites, a good percentage of occupational accidents is due to malfunction of the support equipment, i.e., equipment used to set up the construction project.

In view of this, it is very important to ensure that all support equipment and accessories not linked to the equipment (e.g. slings) are in good condition and regularly checked.

The form in Figure 24 may be used for this purpose. It is based on the European Union Directives and so it should be adapted to the laws and regulations of each country.

<b>L AD</b>	<b>MONITORING THE SUPPORT EQUIPMENT AND ACCESSORIES</b>										Revision	Page					
	Construction Site: _____										Code: _____						
Owner: _____					OSH Expert: _____												
Supervisor: _____					Contractor: _____												
REC. Nr.	Code	SUPPORT EQUIPMENT, INCLUDING THE ACCESSORIES NOT PERMANENTLY LINKED TO THE EQUIPMENT			MANUFACT. PLATE (1)		EC MARK & EC DEC. OF CONFORMITY (2)		NOISE AND VIBRATIONS OF THE EQUIPMENT (3)		PERIODIC REVISIONS		STATE OF EQ. (Visual check)		NON CONF. Nr.	RESPONSIBLE FOR CONTROL SIGNATURE	SUBST. REC. Nr.
		Name	Serial Nr.	Year of Manuf.	Conform?	NA	Conform?	NA	Accomplish?	Updated?	Conform?	Yes	No	Yes			
Prepared by: _____					Verified by: _____					Approved by: _____							
<small>Notes: (1) Manufacturer plate / identification must include name and address of the manufacturer, mark, model, serial number and year of manufacture; (2) EC Mark on the equipment and EC Declaration of Conformity according to the EC Directive 98/37/EC, (2006/42/EC from 2010.08) (Machinery Directive); (3) Accomplishment of the EC Directive n.º 2000/14/EC (noise emission in the environment of equipment for use outdoors) on the marking on the equipment of the guaranteed sound power level (L<sub>WA</sub>) and Directive n.º 2002/44/EC (Vibrations).</small>																	

Figure 24 – Form for monitoring the support equipment and accessories



This form lists all equipment on the construction site and, for each equipment, the following information should be recorded:

- manufacturer slab / identification, including name and address of the manufacturer, mark, model, serial number and year of manufacture;
- EC Mark on the equipment and EC Declaration of Conformity according to the EC Directive 2006/42/EC (Machinery Directive);
- accomplishment of the EC Directive Nr. 2000/14/EC (noise emission in the environment of equipment for outdoors use) on the marking on the equipment of the guaranteed sound power level (Lwa) and Directive Nr. 2002/44/EC (Vibrations);
- information on the periodic revisions (checking if it is updated or not) according to the manufacturer instructions;
- a general visual check of the equipment to detect any malfunction of its parts;
- recording the number of a non conformance, if it is the case, including a brief description and the corrective and/or prevntive measures to take;
- name of the person responsible for checking the equipment.

## 8.2 OSH control measures related to construction operations and/or elements

The basic resources (labour, materials and equipment) are used to perform construction operations or elements thereof. This involves other hazards/risks making it important to monitor these construction operations or elements.

Figure 25 gives an example of a form to do this. It should be prepared and used by the constructor (self-control). The construction supervisor should also be involved in checking the tasks marked as stop points (SP), i.e. important checks in terms of the potential hazards/risks involved.

MONITORING AND PREVENTION PLAN (MPP)										Revision	Page										
		Construction site:						Code:													
		Owner:			Safety expert:																
		Supervisor:			Contractor:																
CONSTRUCTION OPERATION/ELEMENT										Code											
Place/Activity:																					
Ref.	Verifications / Tasks	Hazards & measures	Inspection frequency	Resp.	SP	Contractor control				Supervisor control											
						C	NC	Signature	Date	C	NC	Signature	Date								
<small>SP - Stop Point to be defined by the Supervisor, where he should intervene to control the process; C - Conform; NC - Non-conformity; Resp. - Responsible for the verification/task; contractor's person; CR - Construction Representative; PM/Ag - General foreman; PM/Co - General control person; SE - Safety Expert; Contractor's person; W/M - Worker; W - Work Instruction.</small>																					
IDENTIFICATION OF THE HAZARDS/RISKS AND RESPECTIVE PREVENTION AND PROTECTION MEASURES																					
N.º	Hazards/Risks	Prevention and Protection Measures									Reference DOCs										
1																					
2																					
3																					
4																					
5																					
6																					
7																					
8																					
9																					
10																					
11																					
12																					
13																					
14																					
15																					
16																					
17																					
18																					
19																					
20																					
Prepared by: _____			Verified by: _____			Approved by: _____															
Final checks to close the MPP			Constructor: _____			Supervisor: _____															

Figure 25 – Form for monitoring construction operations/elements



Figure 26 gives an example of this form for monitoring the execution of groups of five reinforced concrete pillars in any floor above the ground of a building.

MONITORING AND PREVENTION PLAN (MPP)										Revision	Page		
Construction site: <i>Construction of a building with ten floors above ground</i>										01	1 / 1		
Owner: XYZ					Safety expert: OSH Management Experts								
Supervisor: Construction Management Experts					Contractor: Building Construction								
CONSTRUCTION OPERATION/ELEMENT										Code			
Execution of reinforced concrete pillars										MPP-015			
Place/Activity: <i>Group of 5 pillars in any floor above the ground</i>													
Ref.	Verifications / Tasks	Hazards & measures	Inspection frequency	Resp.	SP	Contractor control				Supervisor control			
						C	NC	Signature	Date	C	NC	Signature	Date
1	Reinforced bars	---	---	---	---	X		<i>Formman</i>	2008-04-02				
1.1	Transport from site to pillar	3	Bef. operation	FMN									
1.2	Place and tie	1,4,5,6	Bef. operation	FMN									
2	Forms	---	---	---	---	X		<i>Formman</i>	2008-04-05				
2.1	Transport from site to the to pillar	1,4,5	Bef. operation	FMN									
2.2	Mounting the forms	1,2,6,7	Bef. operation	FMN									
3	Concrete	---	---	---	---								
3.1	Concrete placing	1,7,9	Bef. operation	FMN FMNg	X	X	<i>Formman General Foreman</i>	2008-04-06		3/F	<i>Supervisor</i>	2008-04-06	
3.2	Concrete vibration	2,5	Bef. operation	FMN		X	<i>Formman</i>	2008-04-07					
4	Dismounting the forms	6,7,8	After period	FMN		X	<i>Formman</i>	2008-04-07	X		<i>Supervisor</i>	2008-04-07	

SP - Stop Point (to be defined by the Supervisor, where he should intervene to control the process); C - Conform; NC - Non-conformity; Resp. - Responsible for the verification/issue (contractor's person); CR - Contractor's Representative; FMNg - General foreman; FMN - Foreman (partial group); SE - Safety Expert (Constructor's person); WK - Worker; WI - Work instruction.

IDENTIFICATION OF THE HAZARDS/RISKS AND RESPECTIVE PREVENTION AND PROTECTION MEASURES			
N.º	Hazards/Risks	Prevention and Protection Measures	Reference DOCs
1	Hand injuries / Carcinomas / Dermatitis (iron oxide, oil for forms)	Use appropriate gloves, use vegetal based oil; avoid direct contact with cement and concrete	Manufacturer instructions
2	Electrocution using electrical tools	Check connections and unprotected cables	SHP-S13 (EQ Control)
3	Fall of the transported material	Fix appropriately the slings in agreement with the WI	WI n.º ?? (slings)
4	Shock of the material with workers	Assure a good communication with the crane operator	PSS-S13 (EQ Control)
5	Overturning of the existent working platform or fall of equipments	Check the existence and resistance of the working platform (1,00 m below the work floor)	WI n.º ?? (working platforms)
6	Fall from height of workers (in special, on the pillars on the edge of the floor)	Check guardrails of the working platforms and/or harnesses fixed to resistant points or to life lines	WI n.º ?? (guardrails) WI n.º ?? (life lines)
7	Overturning the form during the concrete placing	Calculate the forms taking into account the method for placing concrete, comply with the form designing; check shoring system and the pressure of beams.	Falsework/Form design; Regulation ??
8	Overturning of the form during its dismounting	Follow the inverse sequence of mounting process; check period of time for dismounting the forms.	Falsework/Form design; Regulation ??
9	Shock of bucket with worker or the working platform	Use buckets with bottom unloading and with flexible sleeve	WI n.º ?? (concrete buckets)
10			
11			
12			
13			
14			
15			
16			
17			
18			
19			
20			

Prepared by: <i>Signature of who prepared</i> 2008-03-16	Verified by: <i>Signature of who checked</i> 2008-03-17	Approved by: <i>Signature of the Supervisor</i> 2008-03-17
<b>Final checks to close the MPP</b>	Contractor: <i>Signature of Contractor's Resp.</i> 2008-04-08	Supervisor: <i>Signature of Supervisor's Resp.</i> 2008-04-08

Figure 26 – Example of a MPP of a construction operation/element

In this example, different working instructions are used in the reference documents (DOCs). These working instructions should indeed be previously prepared by the constructor. Many construction enterprises do have usually a number of typical working instructions that they use in different construction projects.



Examples of possible measures to prevent the main hazards/risks in the construction industry are given in Table 11.

**Table 11: Examples of measures to prevent some of the main hazards/risks in construction**

Hazards/Risks	Possible measures related to collective protection
<b>Falls from height</b>	Guardrails on the edge of the floors under construction and in all existing openings (space for the elevators, opening shafts, etc.); Safety nets in the exterior; Correct use of scaffolding; correct use of manual stairs; execution of reinforced pillars and walls using forms that incorporate the working platforms (integrated safety system); ...
<b>Falls at the same level</b>	Keep all construction site clean; arrange the areas for materials and equipment in good order; ...
<b>Cave in</b>	Use adequate trench lining systems; execution of slopes taking into account the nature of the soil and the atmospheric conditions; Delimitation of the deep excavations with guardrails including toeboards;
<b>Electrocution</b>	Placement of protection guardrails to avoid the contact with electrical lines and/or electrical equipment; ...
<b>Fall of objects</b>	Execution of coverings of the accesses to the building under construction to protect the workers and also the public where the building confines with a public way; use scaffoldings covered by nets to avoid the fall of objects onto the public ways; ...

As referred to above, falls from height are the main cause of fatal accidents in the construction industry and special attention should be paid to prevent them. Prevention measures against falls from height may be grouped in two main categories:

- Measures to avoid the falls (guardrails, scaffolding, working platforms, etc.);
- Measures to limit the effects of the falls (safety nets, safety harnesses attached to life lines, etc.).

In both cases, they may be collective measures (primary measures) or personal measures (secondary measures). Collective measures should take priority over personal measures (these should mainly be a complement of the other). The examples given below are all collective measures.

The use of all these prevention measures on construction sites should be duly planned according to the needs. The selection of the most effective methods to use on a construction site should also be carefully decided and their technical specifications detailed in the Safety and Health Plan referred to in subsection 91.

The technical specifications of each of the prevention measures are indeed very important. For example, the use of a guardrail on the edge of a floor is a good measure to prevent falls from height, but will not be efficient if the technical characteristics/specifications (height, resistance, etc.) are not appropriate.

The laws, regulations and/or standards in many countries define the technical characteristics of the main prevention measures and so the labour inspectors have the duty to check their compliance. Different requirements may be used in different countries.

Although a detailed reference to the technical characteristics/specifications of the above mentioned prevention measures is out of the scope of this document, it is important to refer to the main characteristics of the most used prevention measures on construction sites (e.g. guardrails, scaffolding and safety nets), i.e. some of those that, if used in an efficient way, could avoid many fatal accidents on many construction sites. The main checks for other important safety elements (lining systems, falsework, etc.) are also included in this document.





The following examples of the technical characteristics/specifications of some of the above mentioned prevention measures are based on European Union standards and so adaptations shall be introduced to take into account the laws, regulations and/or standards of each country.

**a) Temporary edge guardrails**

The temporary edge guardrails on construction sites are among the most important temporary edge protection systems to avoid falls from height. According to the European Union standard EN 13374:2004, the guardrails may be divided into 3 classes as shown in Figure 27 (for details please refer to the standard).

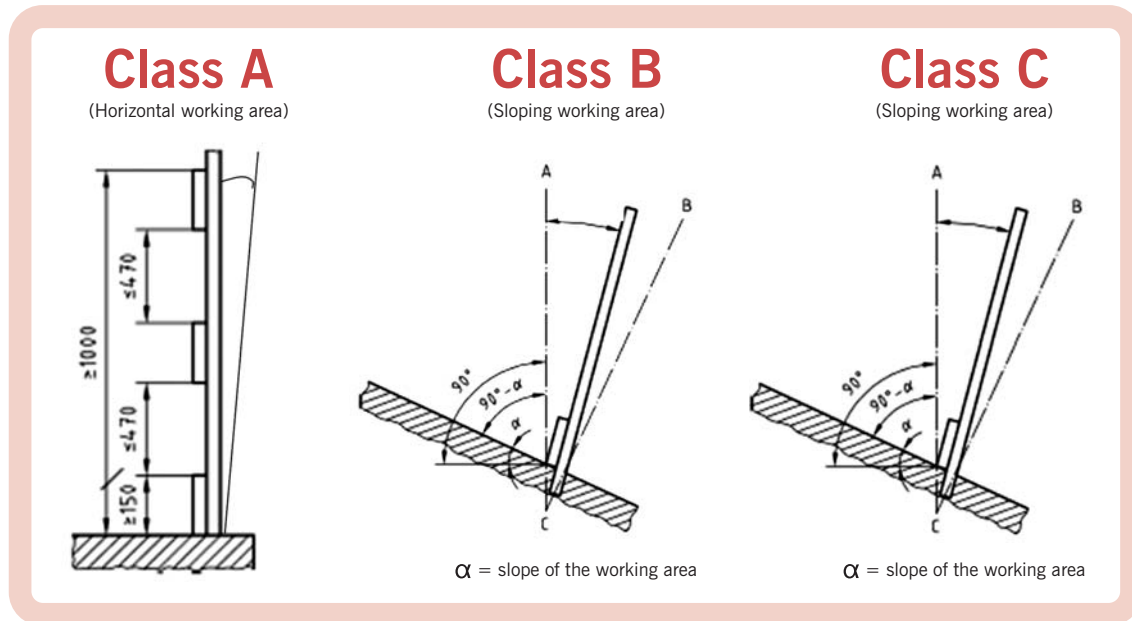

Figure 27 – Classes of temporary guardrails (EN 13374:2004)

Different technical characteristics/specifications may be used in each country, including the height of the guardrail that usually ranges between 1,00 to 1,20 meters. Some of these technical characteristics are shown in Figure 28.

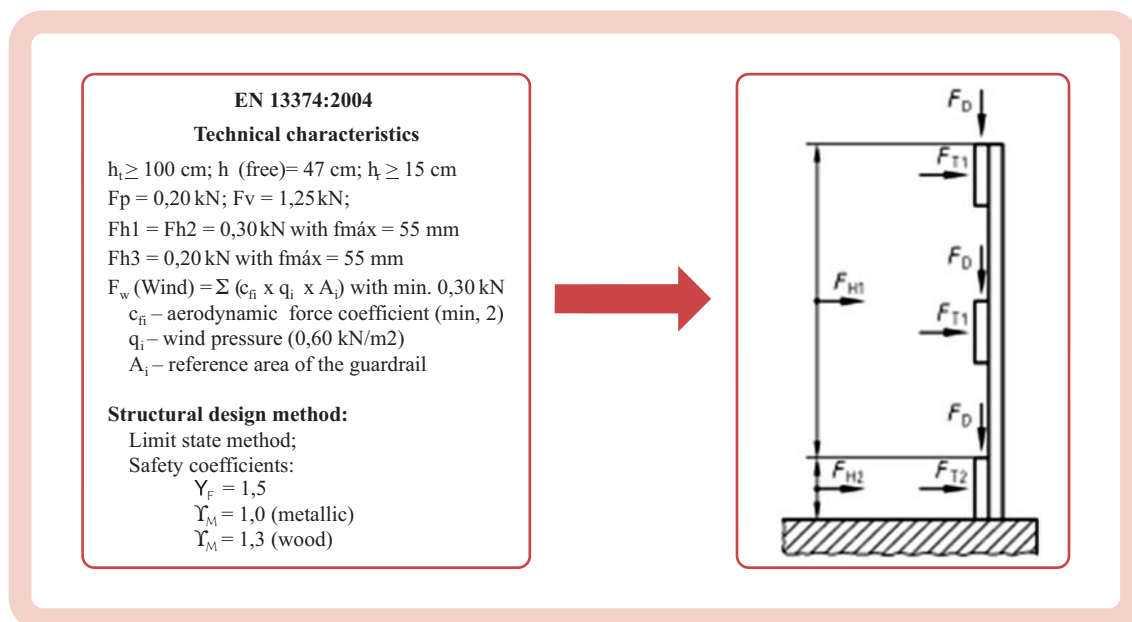

Figure 28 – Technical characteristics/specifications for temporary guardrails (EN 13374:2004)



Taking into account the existing characteristics/specifications, at the practical level the following could be used as a reference:

- Principal or top guardrail at  $h = 1,10 \pm 0,10$  metres, designed for the most adverse situation between an uniformly distributed load of 0,75 kN/meter and a concentrated load of 0,90 kN applied to the middle of the guardrail in both directions (vertical and horizontal), with a deflection of no more than 55 mm without failure;
- Intermediate guardrail at  $h/2 \pm 0,05$  metres, designed for the most adverse situation of a concentrated load of 0,70 kN applied in both directions (vertical and horizontal) to the middle of the intermediate guardrail, with a deflection of no more than 55 mm without failure;
- Toeboard with  $0,20 \pm 0,05$  metres, designed for a horizontal concentrated load of 0,70 kN applied to the middle of the toeboard, with a deflection of no more than 55 mm; the gap between the toeboard and the working surface (where the workers stand) should not exceed 5 mm;
- Posts (vertical support to which the horizontal guardrails are attached) should be designed to support the most adverse situation between the resulting loads from the horizontal guardrails (top and intermediate) and a concentrated load of 0,90 kN applied to the top of the post, with a deflection of no more than 55 mm without failure.

During the inspection of the temporary guardrails on a construction site, the main checks to be performed may include:

- Identification of the place of the guardrail system, material of the posts (steel, aluminium, wood or other), material of the guardrails and toeboard, guardrail class (A, B, C), guardrail height (top, intermediate and toeboard);
- If prefabricated guardrail, clearness of the identification (marking) of the guardrail system and all its components, including manufacturer, year of manufacture or traceability code;
- If non-prefabricated guardrail, verification of the responsibility document of the designer of the guardrail and his/her official qualification for the design, as well as the verification of the inspection documents of the components of the guardrail and/or their marking;
- If prefabricated, availability of the Product Manual in the country language, including the instructions for assembling, fixing to the structure and dismantling;
- Analysis of the assessment report of the guardrail system made before use, performed by a different person from the designer;
- General assessment of the guardrail system on site before the first use, including the fixings made to the structure;
- General assessment of the guardrail every three months;
- General assessment of the guardrail after any change in its previous position on site;
- General assessment of the guardrail after any accident or incident due to the malfunction of the guardrail or following adverse atmospheric conditions.

#### **b) Temporary working scaffolds**

The temporary working scaffolds are equipments used to support many different works on the construction sites, as for example façade scaffolds, static towers to access high levels (e.g. of a bridge under construction), falsework and many other. They may be prefabricated or be built on-site using loose tubes and unions. The materials used include:

- Steel (minimum characteristics defined in EN 74, S235,  $P_v = 7850 \text{ kg/m}^3$ ,  $E = 210\,000 \text{ MPa}$ );
- Aluminium (minimum characteristics defined in EN 74  $P_v = 2700 \text{ kg/m}^3$  and  $E = 70\,000 \text{ MPa}$ );
- Wood (minimum characteristics defined in EN 338, min Class C16);
- Other materials depending on each country (e.g. bamboo, etc.).

The façade scaffolds are the type of temporary working scaffolds most used on many construction sites. For these, in the European Union their specifications are included in the standard EN 12810-1:2003,



which establishes a classification system for the prefabricated scaffolds as shown in Figure 29 and limiting their use to the height of no more than 25,50 meters.

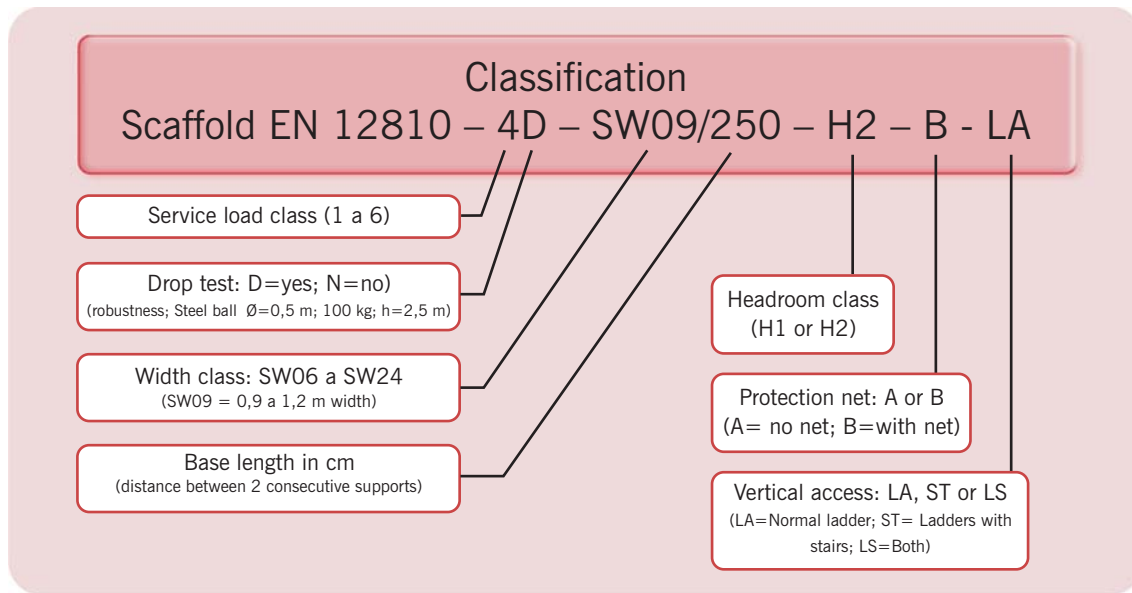

Figure 29 – Classification of a working scaffold

This classification is based on different classes related to the main characteristics, which are defined in the European Union standard EN 12811:2003. These classes, applied to all types of scaffolds, are summarised in Figure 30 and Figure 31 (for details please refer to the mentioned standard).

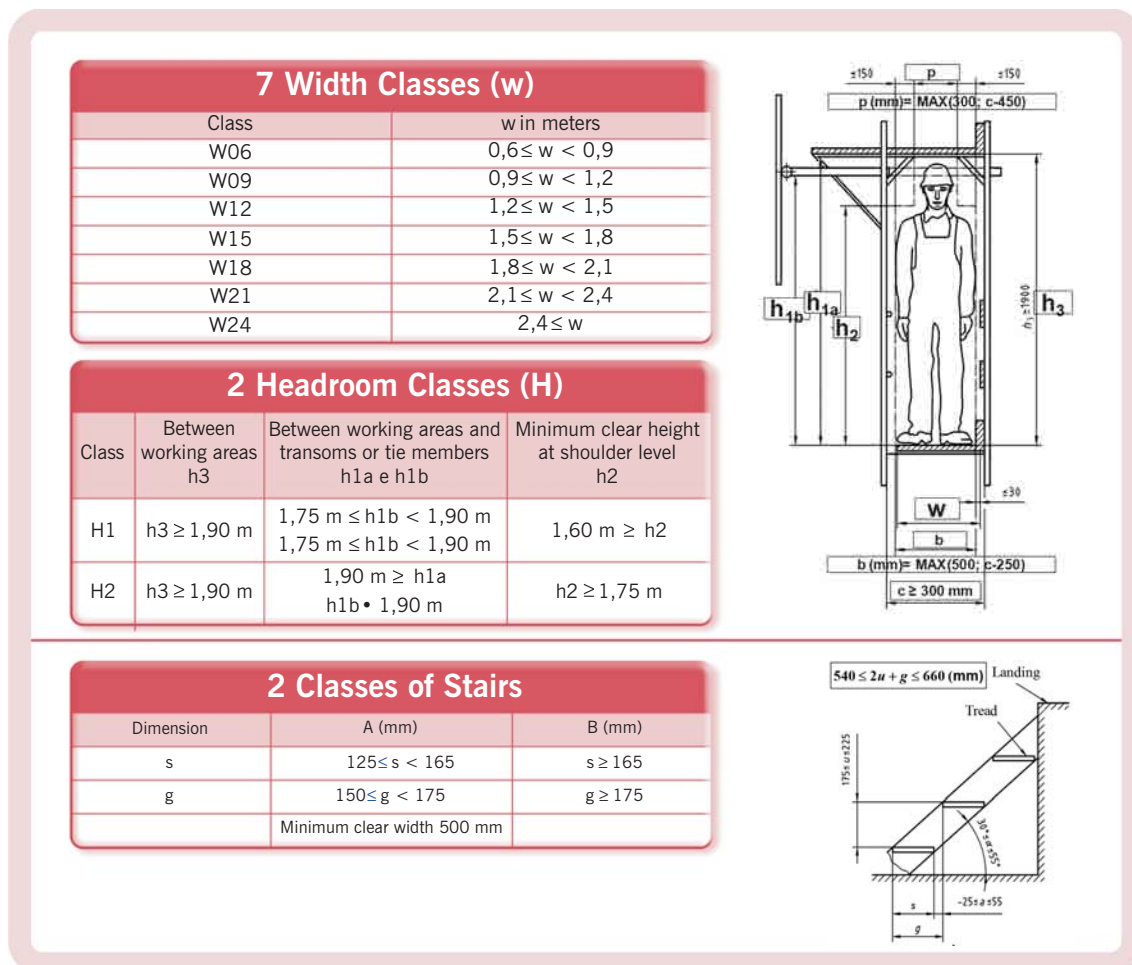

Figure 30 – Width, Headroom and stair classes of a scaffold

6 Service Load Classes					
Load class	Uniformly distributed load $q_1$ , kN/m <sup>2</sup>	Concentrated load on area 500 mm x 500 mm $F_1$ , kN	Concentrated load on area 200 mm x 200 mm $F_2$ , kN	Partial area load	
				$q_2$ , kN/m <sup>2</sup>	Partial area factor $a_p$
1	0,75	1,50	1,00	---	---
2	1,50	1,50	1,00	---	---
3	2,00	1,50	1,00	---	---
4	3,00	3,00	1,00	5,00	0,4
5	4,50	3,00	1,00	7,50	0,4
6	6,00	3,00	1,00	10,00	0,5

Examples of construction works and their different service load classes:

1	→	Inspection and operation works with light tools and no deposit of MT
2	}	Inspection and operation works without deposit of MT, except those needed immediately, as for paintings, stone cleaning, etc.
3		
4	}	Works involving deposit of MT as bricks and other similar materials, etc.
5		
6	→	Works involving heavy materials and other important MT.

Figure 31 – Service load classes of a scaffold and their application

During the inspection of a temporary scaffold on a construction site, the main checks to be performed may include:

- Identification of the place of the scaffold and type (façade, tour, etc.), base material (steel, aluminium, wood or other) and if prefabricated (only for  $h \leq 5,5$  m) or non-prefabricated (any height  $h$ );
- Identification of the scaffold (classification/designation) based on: service load class (1-6); without or with drop test (N, D); class width (W06-W24); headroom class (H1, H2); without or with cladding (A, B); vertical access with ladder, stairs or both (LA, ST, LS);
- If the scaffold is prefabricated, check the clearness of the identification of the scaffold system and all its components, including manufacturer, year of manufacture or traceability code;
- If the scaffold is not prefabricated, check the responsibility document of the designer of the scaffold and his/her official qualification for the design, as well as the verification of the inspection documents of the components of the scaffold and/or their marking;
- If the scaffold is prefabricated, availability of the Product Manual in the country language, including the instructions for erection, use, modification and dismantling;
- Analysis of the test and assessment report of the scaffold made before use, performed by a different person from the designer, including the verification and record of the anchorages and foundations of the scaffold according to the loads of the design;
- General assessment of the scaffold on site before the first use, including the side protection which should have a principal ( $h=1,00$  m) and intermediate guardrail ( $h/2$ ) and toeboard ( $=0,15$  m);
- General assessment of the scaffold every three months and after any interruption on the use of the scaffold for more than one month;
- General assessment of the scaffold after any change in its previous position on site and after any changing of the conditions of use (e.g. different loads);
- General assessment of the scaffold after any accident or incident due to the malfunction of the scaffold or following adverse atmospheric conditions.



**c) Temporary safety nets**

Temporary safety nets are used more and more in many countries as a good prevention measure to limit the effects of falls from height. In some cases they have also been used to prevent the falls of objects onto a public area (e.g. roads). They should be considered as a complement of other measures (e.g. of the guardrails) and not as a primary prevention measure as they do not avoid the falls (which is the first principle of prevention as referred to in subsection 7.1).

In the European Union the specifications of safety nets are included in the standard EN 1263:2002. It establishes a classification system as shown in Figure 32 and limits their use for a height of fall of no more than 6,00 metres.

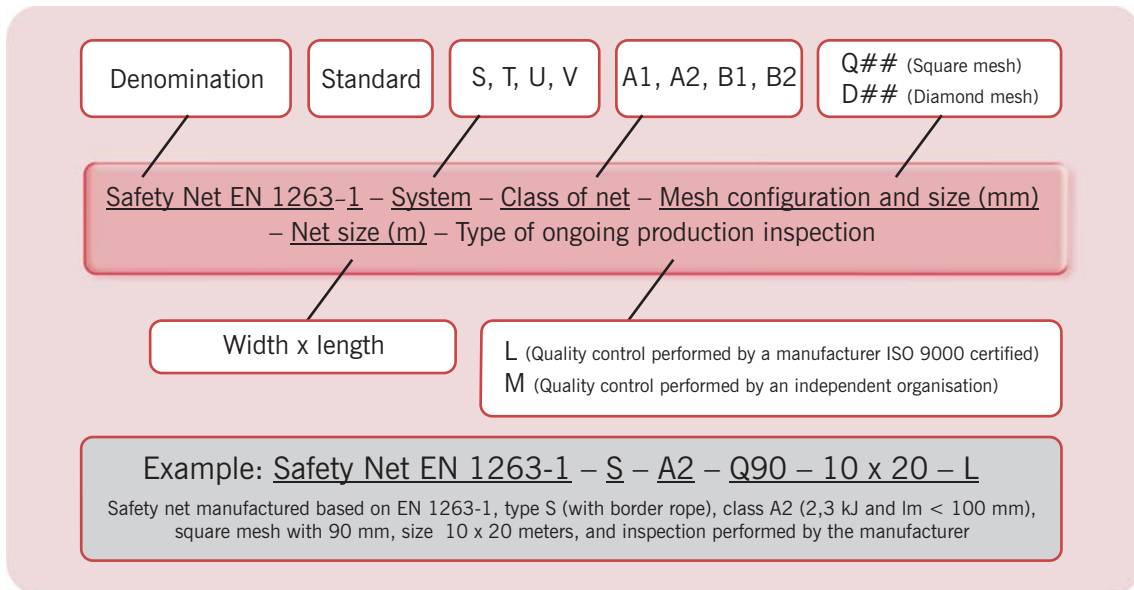

Figure 32 – Classification of temporary safety nets

This classification is based on four systems of temporary safety nets as shown in Figure 33 and four classes as shown in Figure 34 (for details please refer to the mentioned standard).

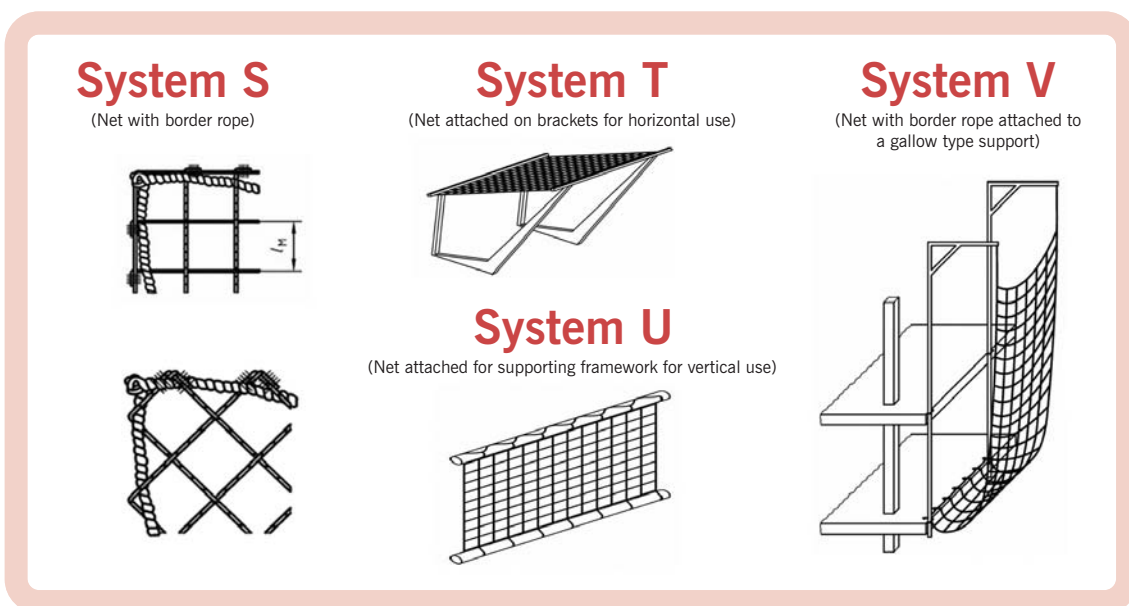

Figure 33 – Systems of temporary safety nets

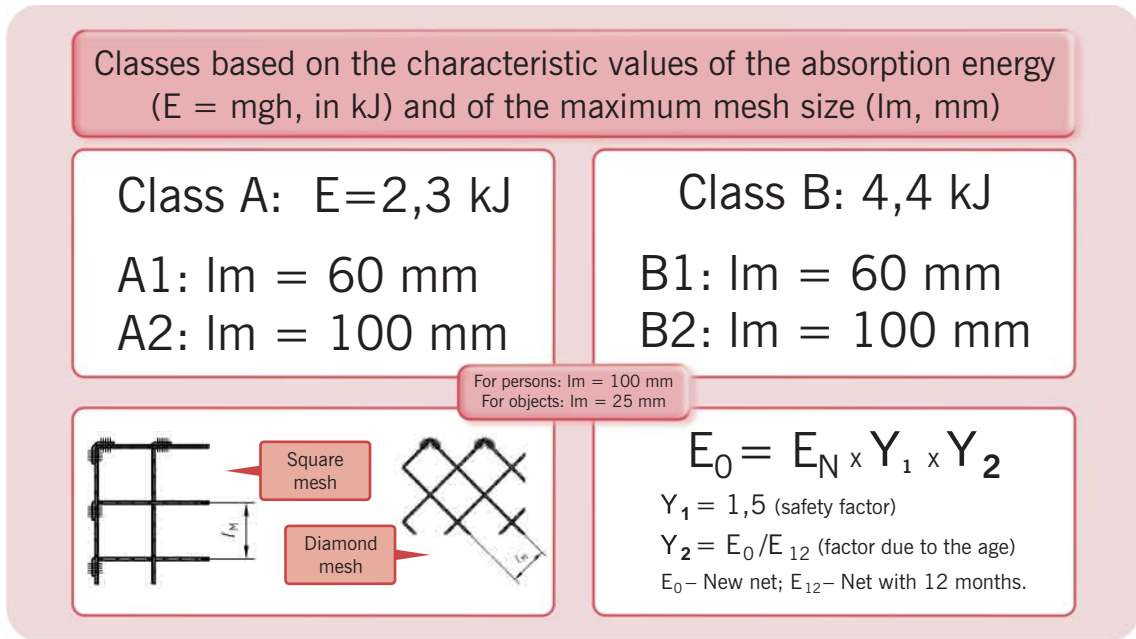

Figure 34 – Classes of temporary safety nets

The standard also establishes other details related to the positioning and anchorage of each of the above mentioned systems, including the maximum fall height and minimum catching width for horizontal safety nets (meaning working areas with a slope of no more than 20°) as shown in Figure 35, and the maximum deformation of the safety nets, which indirectly gives an indication of the clear height under the safety net as shown in Figure 36.

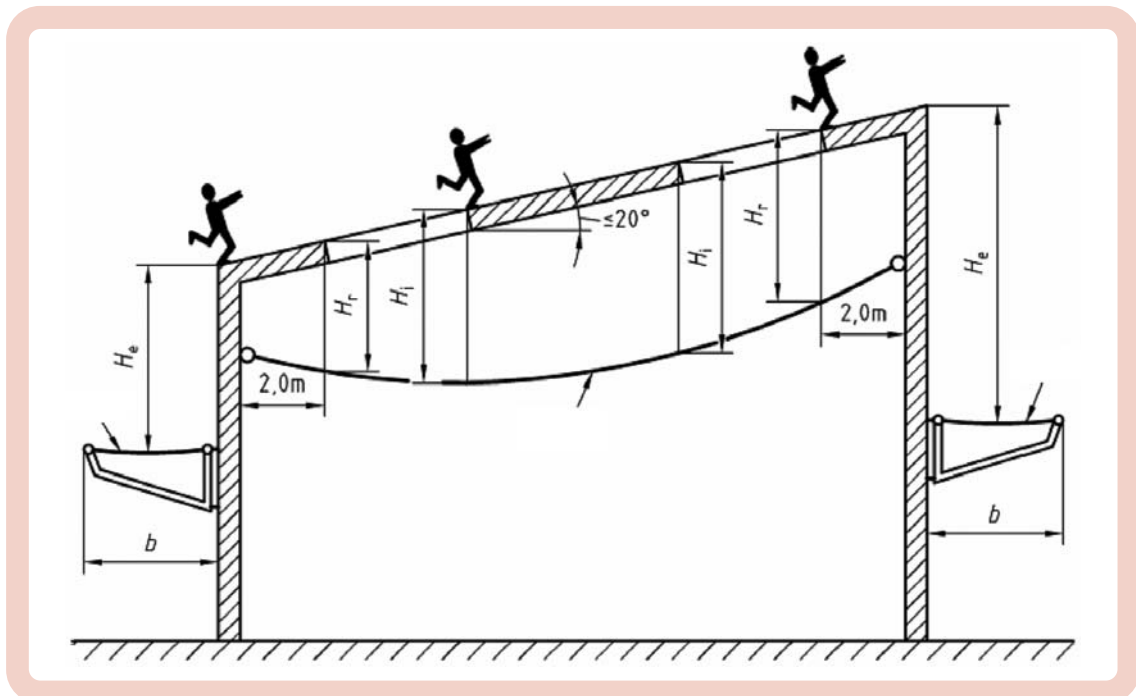

Figure 35 – Maximum fall height and minimum catching width of safety nets



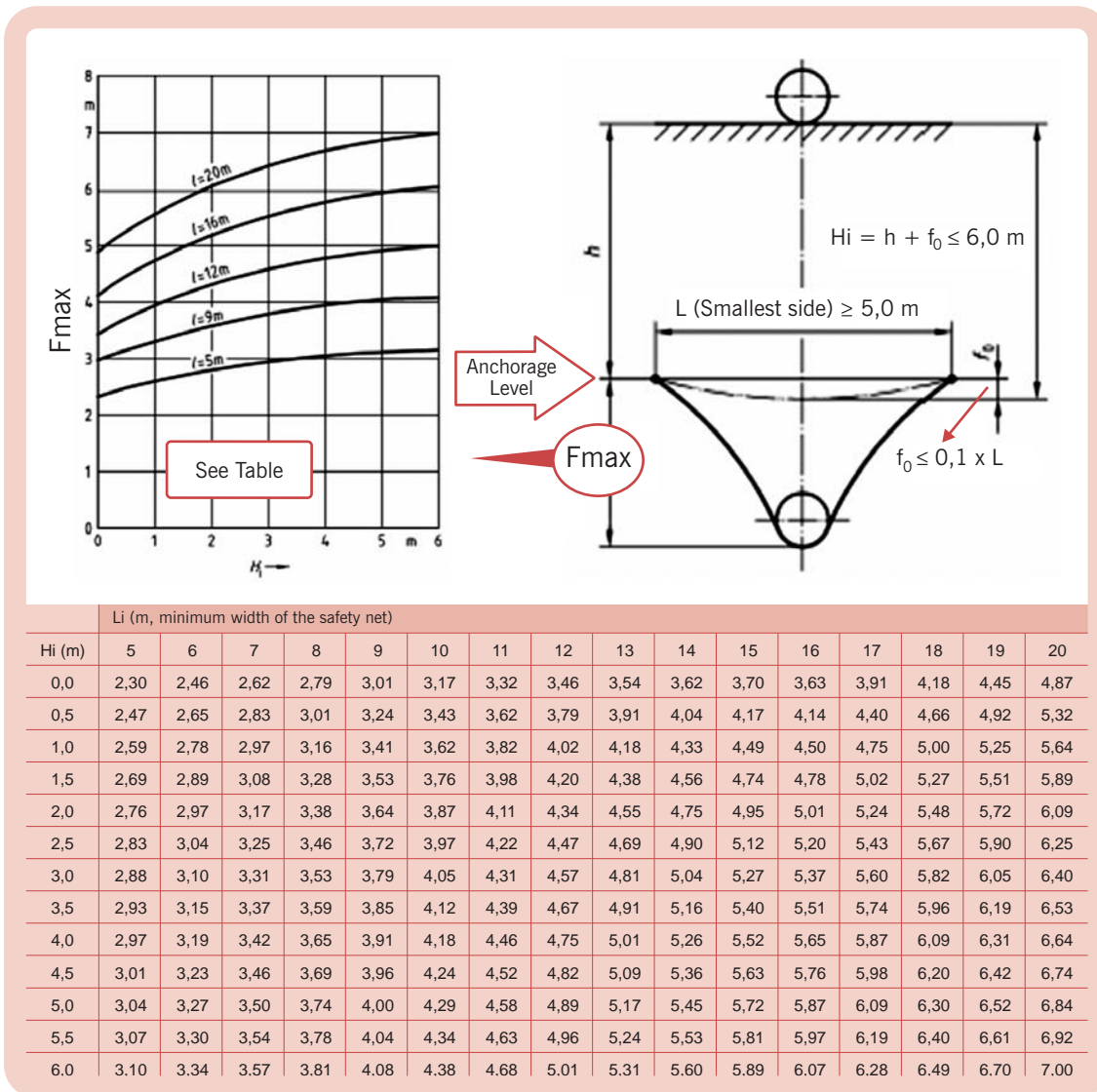

Figure 36 – Maximum deformation of temporary safety nets and clear height under it

During the inspection of temporary safety nets on construction site, the checks to be performed include:

- Identification of the place of the safety net and base material of support (steel, aluminium, wood or other); prefabricated or non-prefabricated;
- Identification of the safety net (classification/designation), net system (S, T, U, V); net class (A1, A2, B1, B2), mesh configuration and size (Q##, D##), net size in metres (width x length) and inspection level of production (L, M);
- If the safety net is prefabricated, clearness of the identification of the safety net and all its components (permanent marking and labelling), including manufacturer, net designation, identification number of the test mesh, year and month of manufacture or traceability code; minimum energy absorption, manufacturer article code;
- If the safety net is not prefabricated, verification of the responsibility document of the designer of the safety net and his/her official qualification for the design, as well as the verification of the inspection documents of the components;
- If the safety net is prefabricated, availability of the Instructions Manual in the country language and declaration of conformity, including the instructions for installation, use and dismantling, storage, care and inspection, conditions for withdrawal from service, any hazards warning (e.g. extreme temperature);

- Analysis of the test and assessment report of the safety net made before use performed by a different person from the designer, including the verification and record of the anchorages according to the loads of the design;
- General assessment of the safety net every three months and before the reuse of the safety net if it is left in the site unused for more than one month;
- General assessment of the safety net after any change in its previous position on site and after any change in the conditions of use (e.g. different anchorages) or an important repair;
- General assessment of the scaffold after any accident or incident due to a fall of a person or an object or following adverse atmospheric conditions (namely, extreme temperatures during a long period).

### 8.3 OSH control measures related to construction sites

Monitoring the basic resources and construction operations or elements, while essential, is not enough to assure a safe and healthy construction site. There are many other checks to perform that relate to the working environment taken as a whole, including the following<sup>9</sup>:

- construction site layout and design (specifications for temporary infrastructure, including water supply, sewage, energy, technical and social installations);
- collective protective plan (temporary equipment and its design details, including guardrails, safety nets, scaffolding, lining systems, etc.);
- access, circulation and signalling plan (pathways for vehicles, persons inside the construction site or surrounding it, signposting);
- evaluation and control of noise and vibrations (based on the limits stipulated by the laws and regulations applicable);
- evaluation and control of the air quality (based also on the limits sets by laws, regulations and/or standards);
- emergency plan (including the evacuation of all those involved on the construction site, whenever a catastrophe or an occupational accident occurs);
- execution plans for specific construction operations or elements and corresponding preventive measures (e.g. excavation plan, plan for breaking rocks using explosives, plans for falsework and concrete placing, plan for deconstruction or demolition).
- When implementing any of the measures, there will be many instances where failure to comply with the specifications, laws or regulations, will be observed.

The form presented in Figure 37 may be used to record these failures (non-conformances and/or non-compliances) and also the corrective and/or preventive measures taken.

---

<sup>9</sup> Details of these controls are beyond the scope of this document. Many of them are specific and highly dependent on the laws and regulations of each country.





	<b>RECORD OF NON CONFORMANCE / NON COMPLIANCE AND CORRECTIVE AND PREVENTIVE ACTIONS (RNC)</b>		Revision ____	Number ____/____ <sup>(1)</sup>
	Construction site: _____			Code: _____
Owner: _____		Safety Expert: _____		
Supervisor: _____		Contractor: _____		
<small>(1) Sequential number: 7. Letter identifying the entity that opens the record. In the case that a RNC should be substituted by another (due for example to changes on the corrective or preventive actions, which have been rejected), the new record of RNC must use the same number followed by a letter a, b, ... respectively, for the 1<sup>st</sup>, 2<sup>nd</sup>, or other substitution. So, the number 8aF means the 1<sup>st</sup> substitution of the RNC n° 8 opened by the Supervisor.</small>				
Entity that opens the record: <input type="checkbox"/> Supervisor (S); <input type="checkbox"/> Safety Expert (SE); <input type="checkbox"/> Constructor (C); <input type="checkbox"/> _____				
Description of the case: <input type="checkbox"/> non conformance; <input type="checkbox"/> non compliance.				
				
Place: _____		Reference of the documents violated: _____		
Described by: _____		Verified by: _____		
Description of the actions to be implemented: <input type="checkbox"/> correctives <input type="checkbox"/> preventives		<input type="checkbox"/> Accepted as proposed; <input type="checkbox"/> Accepted the actions proposed in the annexe ____ constituted by ____ pages; <input type="checkbox"/> Accepted but on the conditions referred to in the annexe ____ constituted by ____ pages; <input type="checkbox"/> Accepted in the following conditions: _____		
Where applicable, description according to the annexe ____ constituted by ____ pages		<small>Note: In the case of rejection of the proposed actions, annexes should be organised with the new proposed actions.</small> Actions to be implemented until: ____ - ____ - ____		
Proposed by: _____		Verified by: _____		Approved by: _____
Verification of the actions effectively implemented: <input type="checkbox"/> It is confirmed that all the approved actions were implemented.				
Confirmed by: _____		Constructor: _____		Supervisor: _____
<b>Final verifications for closing this record</b>		Constructor (Resp.): _____		Supervisor (Resp.): _____

Figure 37 – Form for recording the non conformance/compliance and corrective/preventive actions

The form in Figure 38, summarises all the main OSH-related issues for each month. It should also be used by the constructor and be very helpful also for all those that have the mission to inspect OSH on the construction site (OSH experts, labour inspectors, etc.).



	<b>OCCUPATIONAL SAFETY AND HEALTH MONITORING (OSH-M)</b>		Revision	Page
	Construction site:		Code:	
	Owner:	Safety expert:		
	Supervisor:	Constructor:		

<b>Notes:</b> a) Where applicable, information related to the last day of the month shall be used; b) All information shall refer to all the contractors, including constructors, subcontractors, subcontractors (work-performed or labour-only basis) and successive subcontracting chain, self-employed, etc.).	<b>Month / Year</b> /
--	--------------------------

GENERAL INFORMATION RELATED TO THE SITE AND MONTH UNDER CONSIDERATION	
Is the nominal flowchart updated? <input type="checkbox"/> Yes; <input type="checkbox"/> No	Is the approved works scheduling being accomplished? <input type="checkbox"/> Yes; <input type="checkbox"/> No
Are the definition of functions of the technical team updated? <input type="checkbox"/> Yes; <input type="checkbox"/> No	Works are <input type="checkbox"/> On day; <input type="checkbox"/> Delayed / <input type="checkbox"/> Advanced days
Nr. of workers on site:	Nr. of support equipment under control (S13):
Nr. of workers of the constructor:	Nr. of relevant works running and concluded:
Nr. of workers of all sub-constructors:	Nr. of work Instructions have been prepared:
Nr. of self-employed workers:	Nr. of MPP have been prepared:
Nr. of workers that stay overnight in the site:	Nr. of non conformities are opened:
Nr. of temporary workers:	Nr. of non conformities are closed:
Nr. of sub-constructors:	Nr. of occupational accidents were reported to Insurers:
Nr. of sub-constructors (below first level of subcontracting):	Nr. of formal training/information actions organised:
Nr. of subcontractors (not sub-constructors), including services:	Nr. of internal audits or inspections performed
Nr. of subcontractors (below first level of subcontracting)::	Nr. of Non-compliance Notices by the Labour Inspection
Nr. of levels of subcontracting:	
Nr. of insurance documents covering occupational accidents:	

RELEVANT EVENTS OCCURRED DURING THE MONTH CONCERNING OSH
(Where needed, include in an annexe the appropriate information, pointing out this fact. Without prejudice of other information that the Contractor considers relevant, the following may be considered: meetings of the OSH Commission; occupational accidents occurred during the period, reasons for the non accomplishment of measures that should be implemented; etc.).

DOCUMENTS INCLUDED IN ANNEXE TO THIS FORM WITH INFORMATION RELATED TO THE MONTH	
<input type="checkbox"/> Document referring to relevant events <input type="checkbox"/> Records related to identification & medical surveillance of workers (S09) <input type="checkbox"/> List of workers that receive PPE and hazards/risks information (S10) <input type="checkbox"/> Control of subcontractors (S11) <input type="checkbox"/> Control of insurance of occupational accidents (S12) <input type="checkbox"/> Control of the support equipment and accessories (S13) <input type="checkbox"/> Control of the MT and incorporated EQ (S14)	<input type="checkbox"/> List of MPP prepared (S15) <input type="checkbox"/> List of non conformities recorded (S16) <input type="checkbox"/> Monthly form summarising the occupational accidents (S18) <input type="checkbox"/> Form with all accidents and OSH indicators (S19)

DECLARATION	
We declare that the information above mentioned, including annexes to this form, correspond to the real situation in this construction site, according to the records that we keep updated and well organised.	
OSH Expert of the Constructor	Representative of the Constructor for this site
Date: / / Sign.: _____	Date: / / Sign.: _____

Figure 38 – Occupational safety and health monitoring

Figure 39 shows a form on which the constructor should record and calculate the main occupational accident statistics based on the Resolution of the Sixteenth International Conference of the Labour Statisticians (ILO, 1998).





In the above statistic indicators the following should be taken into account:

- A fatal occupational injury should be measured as an occupational injury leading to death within one year of the day of the occupational accident causing the injury;
- The reference group should be all workers on site, including the management;
- The reference period should be the time scheduled for the construction project and/or, where applicable, converted to one year (multiplying by 12/nr. of months of the project);
- The average number of persons on site should be calculated based on the total number of hours worked (person-hours worked) divided by the average number of hours worked per month and per each worker, considering 4 weeks per month multiplied by the number of hours per week according to the law (e.g. 4 weeks x 40 hours/week = 160 hours);
- Days lost should be measured inclusively from the day after of the accident to the day prior to return to work and in terms of the number of calendar days during which the injured person is temporarily incapacitated;
- The statistics should cover all occupational injuries, including fatal injuries and non-fatal injuries causing an absence from work of at least one day, excluding the day of the accident; the injuries resulting from commuting accidents should be compiled and disseminated separately.

Moreover, when using these OSH statistics to evaluate a construction enterprise, attention must be paid to the fact that they must reflect not only the occupational accidents involving the workers engaged by the construction enterprise, but also all those that occurred in the construction projects under its coordination, i.e. including those involving workers engaged by the subcontractors.

This applies also at the construction site level, i.e., the above statistics should include all the occupational accidents occurred on the construction site involving all the workers engaged by the enterprise and all those engaged by their subcontractors and successive chain of subcontracting and self-employed workers.



## Instruments and methodology for inspection visits

The main objective of any OSH inspection programme is to contribute to the reduction of occupational accidents and diseases. For this mission, the labour inspectorates make use of instruments to enforce the application of the existing OSH laws and regulations of the country by all those involved in the life cycle of construction projects.

The high number of OSH laws and regulations, general or specific to the construction sector, and the different times at which they were issued can make it more difficult to apply them and inspect their application in a systematic way.

However, more and more countries require the preparation of specific documents dealing with each construction project. By summarizing the legislation applicable to each case, identifying hazards/risks and setting out preventive measures, these documents facilitate both application and inspection.

These documents are usually called the Safety and Health Plan (SHP) and the Safety and Health File (SHF). Both aim to identify, evaluate and prevent hazards/risks, the former (SHP) during the execution phase and the latter (SHF) during the use/operation/maintenance phase.

The enforcement and preventive instruments are presented in subsection 9.1. They should be used by the labour inspectors during their inspection visits to the construction sites.

These inspection visits to the construction sites by the labour inspectorates follows usually a methodology established previously. Sometimes, they are prepared to cover specific issues (e.g. labour control, as per the existence of unrecorded national and/or foreign workers, compliance with medical surveillance), including combined inspections involving other local authorities with the authority given by law to inspect particular issues (e.g. control of the equipment used on construction sites).

In subsection 9.2, a methodology for general inspection of a construction site in a systematic and structured way is proposed, including an evaluation system giving information on the results of the inspection at a global level and at a detailed level. This methodology is based on checklists that should be adapted for each construction site.

### 9.1 Instruments for inspection visits

This subsection presents and briefly describes the main enforcement and preventive instruments for labour inspectors to use on inspection visits<sup>12</sup>.

#### a) Enforcement instruments

Labour Inspectorates have to ensure the application of the OSH laws and regulations. For this, they may use one or more of the following enforcement instruments (Figure 40):

- verbal warning;
- written warning;

<sup>12</sup> A detailed description of the preventive instruments (SHP and SHF) is beyond the scope of this document, as both are highly dependent on the type of construction project and on the specific legislation of each country.

- fine / penalty;
- cessation of work;
- legal prosecution.



Figure 40 – Enforcement instruments

Complementary enforcement measures include publicizing (e.g. through the Web pages of the labour inspectorate) the enforcement instruments used during inspection visits to a construction enterprise or site. This example of complementary enforcement measure may only be used if the country's law explicitly allows it.

However, there is no common practice on the application of these enforcement instruments. Whereas some countries favour the application of fines, others favour the warnings (verbal and/or written) or education and prevention, rather than just inspection and prosecution.

In 2004, the Senior Labour Inspectors Committee (SLIC, 2005) of the 15 countries of the European Union launched a campaign on 25 000 construction sites. About 50 000 instances of non compliance were detected. About 60% led to written warnings, and about 80% of them were used on construction sites with 20 workers or less (Figure 41). The application of fines and cessation of work were found to be the most effective enforcement instruments.

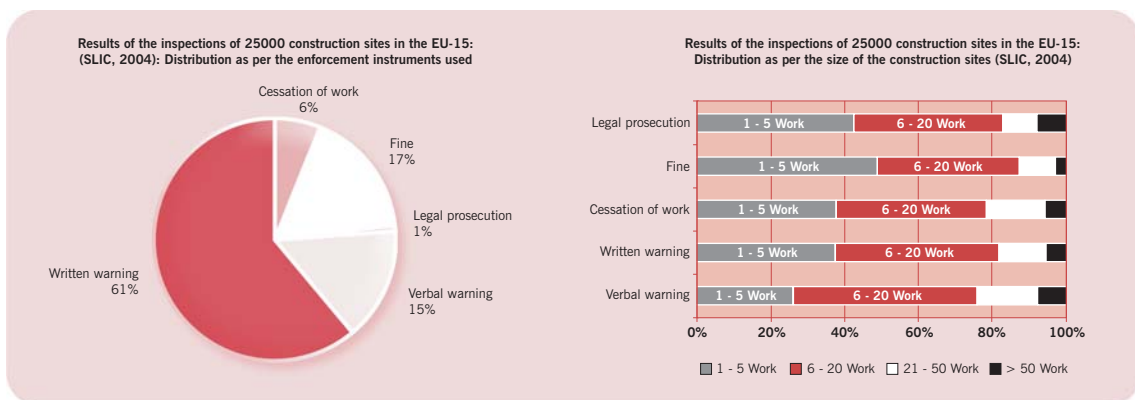

Figure 41 – Results of the inspection of 25000 construction sites in the EU (SLIC, 2005)

In view of the differences among countries (and sometimes, within the same country in different regions or by different inspectors) in the application of enforcement instruments, it is very important to harmonise the procedures for the application of each enforcement instrument taking into account the cultural and legal differences between countries.



For this purpose, the instances of non-compliance observed during an inspection visit should be classified into three main groups (Figure 42):

- Light;
- Severe;
- Very severe.

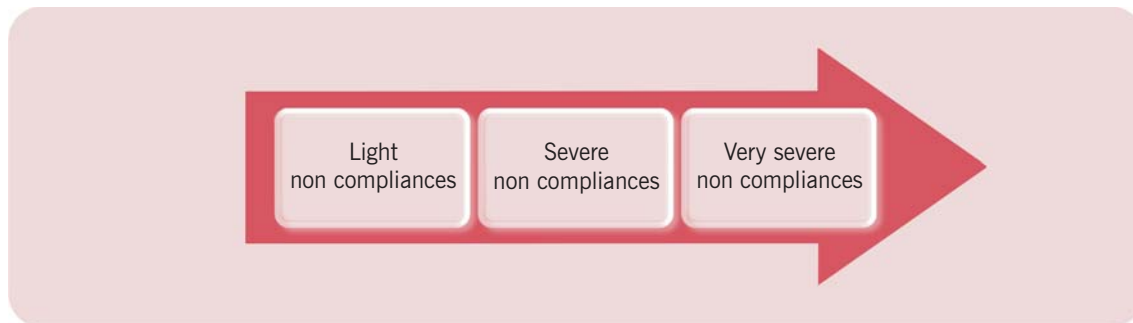

Figure 42 – Groups of non compliances

**“Light non-compliances”** include non fulfilment of the arrangements established by the OSH related laws or regulations and any reference document specifically applicable to the construction project under consideration (the safety and health plan, the safety and health file, the project specifications, etc.), which:

- (i) do not cause direct and immediate risks to the safety and health of any person working on the construction site or the public; and
- (ii) may be corrected soon (e.g. within one day).

Examples include the absence of a signature on administrative documents, an incomplete record of personal protective equipment, incomplete hazard/risk information to the workers and other administrative failures. In general terms and depending on each case, these non-compliances are associated with verbal and/or written warnings.

**“Severe non-compliances”** are all other situations of non fulfilment, for example:

- starting any construction operation without a monitoring and prevention plan (see 8.2);
- total or partial absence or inadequacy of any collective or personal protective equipment;
- absence of proof that any worker on site (randomly identified) is covered by a valid and up-to-date insurance against occupational accidents, or has no up-to-date record of medical surveillance;
- absence or inadequacy of any of the plans referred to in the safety and health plan for the construction site under consideration (e.g., emergency plan, collective or personal protective plans, etc.);
- inadequate habitability and hygiene conditions;
- presence on the construction site of any unrecorded contractor or subcontractor;
- absence of, inadequacy of or non compliance with the information training plan;
- non compliance with the time schedule of any person referred to in the flow chart of the construction site;
- absence or inadequacy of the written description of the functions each of them should perform, especially, in relation to OSH issues;
- non-investigation of any occupational accident or the absence of measures taken to stop the same type of accident happening again.

Depending on each case, these severe non-compliances are associated with written warnings and/or on-the-spot fines.

Whenever these severe non-compliances involve direct and immediate risk to the safety and health of any person working on the construction site or of the public, or the absence of the prevention measures may cause (or have already caused) a severe occupational accident, they should be considered as “**very severe non-compliances**”. These non-compliances are associated with the cessation of work or even the legal prosecution.

Any non-compliance (light, severe or very severe) recorded by the labour inspectors should be supported by the reference document whose stipulations were not fulfilled, otherwise it should be considered as just an opportunity for improvement. The reference documents (other than a law or regulation), or part of them, and evidences gathered of non compliance, should be kept by any means (e.g. photocopy, photography) and attached to the report on the inspection.

Table 12 illustrates a possible strategy for enforcement after observing con-compliance during an inspection. However, it should be adapted to the cultural and legal practices of each country.

**Table 12: Possible use of the enforcement instruments in view of the non-compliances**

Non-compliances	Light non-compliances					Severe and very severe non-compliances				
	VW	WW	F	CW	LP	VW	WW	F	CW	LP
1. Not supported by a reference document	X					X				
2. Not corrected within the time period fixed		X						X		
3. Not implying direct and immediate risks, corrected during the inspection period and re-verified	X									
4. Implying direct and immediate risks, although corrected during the inspection period and re-verified							X			
5. Not implying direct and immediate risks, but to be corrected within a short period of time		X								
6. Implying direct and immediate risks, but to be corrected within a short period of time								X	XX	
7. Implying direct and immediate risks or the absence of the prevention measures may cause (or have already caused) a severe occupational accident on the site									X	XX
8. Incomplete administrative records, with no significant influence on OSH	X									
9. Incomplete administrative records, but with significant influence on OSH		X					X	XX		
10. Same or similar to a non-compliance recorded in any previous inspection visit to this site, but no accident was previously caused by the absence of the correction			X						X	
11. Same or similar to a non-compliance recorded in any previous inspection visit to this site, but an accident has already been caused by the absence of the correction				X					X	XX

VW – Verbal Warning; WW – Written Warning; F – Fine; CW – Cessation of Work; LP – Legal Prosecution; “X” means a possible enforcement instrument to be applied; “XX” means a possible alternative to be applied for more severe non-compliances.

Whenever an inspection uncovers more than a certain number of “light non-compliances” (e.g. 10), of “severe non-compliances” (e.g. 5) or of “very severe non-compliances” (e.g. 1), a new inspection should be scheduled to follow up and to confirm that the non-compliances have been corrected. A full inspection may also be made then, especially if the number of “non-compliances” was more than double the number that calls for a follow up inspection.





Another important issue is whether the labour inspectors should make recommendations during the inspection visits. It is not usual and it is not a duty of the labour inspectors to do so, although some do make recommendations, usually verbally.

However, labour inspectors should make any recommendations in a pro-active way, when they are sure about the way to correct the non-compliance and there is only one way to do so according to a specified reference document. In these cases, and only in these, the recommendations should be given in writing, making them part of process, i.e., part of the enforcement instrument.

### **b) The Safety and Health Plan**

The Safety and Health Plan (SHP) is the main hazard prevention document. It aims to identify and evaluate OSH hazards/risks and preventive measures on the construction site. It should be available before any work starts and it must include the measures to be taken by all those involved in the construction process, to whom it should be available, namely the supervisors, safety and health coordinators, contractors, subcontractors, self-employed persons and workers' representatives.

Preparation of the SHP should start during the design process. It should be included in the tender process, where applicable, so that all bidders may budget for the measures when preparing their proposals. It is a dynamic document which should be updated, adapted and complemented after contract has been awarded and throughout the construction period.

Records of the measures taken should also be required. Having one SHP for the design phase and another for the construction phase, leads to static documents of dubious efficiency.

A SHP should be required for all construction projects independently of their size and complexity with some exceptions<sup>13</sup>, namely, for medium and large construction projects based on the conditions for a Prior Notice (see subsection 4.1) and/or where particular risks are involved (see subsection 7.1). However, the minimum contents (but not the structure) of the SHP should be included in the laws or regulations and vary according to the size, complexity and environment around each construction project; simplified versions of the SHP should be considered. Table 13 gives an example of the contents of a possible SHP for a medium/large construction project, which must, of course, be adapted to the characteristics of each construction project.

---

<sup>13</sup> Some countries of the European Union do not require a SHP for small jobs inside a private home.

**Table 13: Example of a possible structure and contents for the SHP**

Promulgation (by the owner's representative)
<b>1. Introduction</b>
1.1 Scope and application ( <i>construction project under consideration and any boundaries</i> )
1.2 Identification of main and general hazards and prevention measures
1.3 Objectives and action plan
1.4 List of legislation and standards applicable to the construction project under consideration
<b>2. Organizational and general procedures</b>
2.1 Distribution of the SHP
2.2 Delivery of the SHP at the start of the works and at the end ( <i>reception of the project</i> )
2.3 Changes to the SHP
2.4 Adapting and complementing the SHP
2.5 Technical archive for records
2.6 Control of signatures and rubrics
<b>3. Procedures related to general, social and training policy</b>
3.1 Functional chart and definition of roles
3.2 Prior notice and its updates
3.3 Safety and health policy
3.4 Timetable ( <i>Working hours</i> )
3.5 Insurance against accidents at work
3.6 Personal protective plan ( <i>identification of workers, PPE</i> )
3.7 Information and training plan
3.8 Health plan
3.9 Visitors' plan
<b>4. Planning and management procedures</b>
4.1 General characteristics of the construction site
4.2 Construction phases
4.3 Existing local conditionings
4.4 Planning of the works ( <i>general analysis and list of relevant works to be performed</i> )
4.5 Planning of labour resources
4.6 Control of construction equipment ( <i>updated revisions, noise, dust or fumes emissions, etc.</i> )
4.7 Control of materials and equipment involving specific hazards
4.8 Works involving particular hazards
4.9 Control of subcontractors and successive chain of subcontracting
4.10 Emergency plan, including evacuation
<b>5. Work instructions and hazard prevention</b>
5.1 Construction processes and methods ( <i>relevant construction elements</i> )
5.2 Collective protective plan
5.3 Monitoring and prevention plan
5.4 Construction site design and layout ( <i>including access and internal circulation and signalisation</i> )
5.5 Temporary signalisation plan ( <i>public area, in special in road construction</i> )
5.6 Scaffolding plan for assembly, use and dismantling
5.7 Excavation prevention plan
5.8 ... ( <i>other specific prevention plans according to the construction project</i> )
<b>6. Follow up and assessment procedures</b>
6.1 Monitoring
6.2 Record of non-conformities and corrective and preventive actions
6.3 Record of accidents and indices, including accident investigation records
6.4 OSH committee for the construction site
6.5 Auditing (internal and external)
6.6 Notifications and reports of the authorities related to the construction site
<b>Annexes</b>
Annex 1 – List and models to be used
Annex 2 – Extracts of the most relevant legislation and standards applicable
Annex 3 - List of relevant works to be performed in the construction site
Annex ? – ( <i>to be created during the construction phase as needed</i> )



Figure 43 shows a possible simplification for this SHP for very small construction projects. It is based on a simple form that includes the main information on the construction project and on annexes that should be attached to it (namely, the forms referred to in section 8 of this document).

<b>L A D</b>	<b>SAFETY AND HEALTH PLAN</b> <b>FOR VERY SMALL CONSTRUCTION PROJECTS</b>	PAGE <b>1 / 1</b>
<i>Project:</i>		<i>Ref.:</i>
<i>Characterisation:</i>		
<b>1</b>	<b>OWNER</b> Name: Address:	<b>Representative</b>
<b>2</b>	<b>DESIGNER</b> Name: Address:	<b>Representative</b>
<b>3</b>	<b>SUPERVISOR</b> Name: Address:	<b>Representative</b>
<b>4</b>	<b>CONSTRUCTOR</b> Name: Address: Constructor's Technical Director: <i>Where applicable, attach to this the list of subcontractors and self-employed workers.</i>	
<b>5</b>	<b>SAFETY AND HEALTH COORDINATOR FOR THE DESIGN PHASE (IF APPLICABLE)</b> Name: Address: <i>Physical person responsible for this coordination (qualified).</i>	<b>Representative</b>
<b>6</b>	<b>SAFETY AND HEALTH COORDINATOR FOR THE EXECUTION PHASE (IF APPLICABLE)</b> Name: Address: <i>Physical person responsible for this coordination (qualified).</i>	<b>Representative</b>
<b>7</b>	<b>DATES OF STARTING AND COMPLETION AND DURATION OF THE CONSTRUCTION SITE</b> Date of start:      Date of completion:      Duration (days):	
<b>DOCUMENTS ATTACHED TO THIS FORM (MARK AS APPROPRIATE)</b>		
<input type="checkbox"/> Document related to the existing constraints <input type="checkbox"/> List of MPP prepared (S15) <input type="checkbox"/> Records of the identification & medical surveillance of workers (S09) <input type="checkbox"/> List of non conformities recorded (S16) <input type="checkbox"/> List of workers that receive PPE and hazards/risks information (S10) <input type="checkbox"/> Monthly form summarising the occupational accidents (S18) <input type="checkbox"/> Control of subcontractors (S11) <input type="checkbox"/> Form with all accidents and OSH indicators (S19) <input type="checkbox"/> Control of insurance of occupational accidents (S12) <input type="checkbox"/> Emergency plan (as a minimum list of emergency phones) <input type="checkbox"/> Control of the support equipment and accessories (S13) <input type="checkbox"/> <input type="checkbox"/> Control of the MT and incorporated EQ (S14) <input type="checkbox"/>		
<b>CONSTRUCTOR'S SAFETY EXPERT</b>		<b>CONSTRUCTOR'S TECHNICAL DIRECTOR</b>
Date: / / Sign.: _____		Date: / / Sign.: _____

Figure 43 – Form for a safety and health plan for very small construction projects



### c) The Safety and Health File

The Safety and Health File (SHF) is the main hazard prevention document after the conclusion of the works, i.e., during the use/operation/maintenance phase. It should contain all OSH information relevant to any subsequent works especially hazards involved when performing any maintenance work.

It is a long-term document which should be kept up to date throughout the project. It should be mandatory for all construction projects for which a safety and health plan is also required.

Like the SHP, the SHF is also a dynamic document whose minimum contents should also be included in the laws and/or regulations and vary according to the size and complexity of each construction project, so that simplified versions of the SHF should be considered.

Table 14 illustrates a possible SHF for a medium/large building project. The contents must of course be adapted to the characteristics of each construction project. There will certainly be significant differences for different types of projects (buildings, roads, bridges, etc.).

During the use/operation/maintenance phase, any significant rehabilitation or modification to the existing construction project mean that new safety and health plan should be drawn up, where required, and the safety and health file should be updated accordingly.



**Table 14: Example of structure and contents for the SHF for a building**

Promulgation (by the owner's representative)
<b>1. Introduction</b>
1.1 Scope and application ( <i>construction project under consideration</i> )
1.2 Identification and addresses of all those involved in the construction process
1.3 Details related to the construction process ( <i>dates of starting and ending, costs involved, etc.</i> )
1.4 List of legislation and standards applicable to the construction project during the maintenance phase
1.5 Regulation for the use of the project, including insurances needed (as for fire insurance)
<b>2. Organizational and general procedures</b>
2.1 Distribution of the SHF at the end to the responsible of the project during the maintenance phase
2.2 Changes to the SHF and adapting and complementing the SHF
2.3 Organization of the technical archive of all documents related to the SHF
<b>3. Project characteristics</b>
3.1 Technical data (construction areas, number of floors below and over the entrance floor, etc.)
3.2 Brief description of the project ( <i>relevant structural aspects, type of external walls, type of cover, etc.</i> )
3.3 Project "As built"
3.4 Details on the connection of internal to external infrastructures (water, sewage, electricity, etc.)
3.5 List of hazardous materials used in the project and prevention measures (asbestos, etc.)
3.6 Relevant quality records ( <i>assurance certificates of materials and equipment, results of tests, etc.</i> )
3.7 Relevant OSH records ( <i>accidents and indexes during the construction phase</i> )
<b>4. Hazard prevention plans</b>
4.1 Signalization plan ( <i>interior and exterior</i> )
4.2 Information and training plan of all those involved in the maintenance phase
4.3 Security plan
4.4 Fire safety plan
4.5 Emergency plan, including evacuation
4.6 Deconstruction and/or Demolition plan ( <i>relevant aspects to take into account</i> )
4.7 ... ( <i>other specific prevention plans according to the construction project</i> )
<b>5. Maintenance procedures</b>
5.1 Interior maintenance ( <i>cleaning, painting, etc.</i> )
5.2 External maintenance ( <i>cleaning, painting, waterproof, etc.</i> )
5.3 Cover maintenance ( <i>substitution of elements, waterproof, etc.</i> )
5.4 Maintenance of electrical installations ( <i>lights, electrical equipment, etc.</i> )
5.5 Maintenance of mechanical installations ( <i>air conditioning, ventilation, heat, water, sewage, etc.</i> )
5.6 Maintenance of elevators and similar equipment
5.7 ... ( <i>other specific prevention procedures according to the construction project</i> )
<b>6. Monitoring</b>
6.1 Periodic inspections ( <i>based on checklists</i> )
6.2 Record of non-conformities and corrective and preventive actions
6.3 Record of accidents including accident investigation, during the maintenance phase
<b>Annexes</b>
Annex 1 – List and models to be used ( <i>namely checklists</i> )
Annex 2 – Extracts of the most relevant legislation and standards applicable
Annex ? – ( <i>to be created during the construction or pos-construction phase as needed</i> )

## 9.2 Methodology for the inspection of construction sites

Inspection visits to construction sites by labour inspectors should take a proactive approach and use a systematic process like the one proposed below.

This proactive approach places responsibility for the OSH measures mainly (but not only) on those in the “front line” of responsibility, i.e. those who have the authority and means to decide on the level of safety and health on the construction site (namely, the owner’s and constructor’s representatives rather than the safety experts).

In contrast to the audits, inspection visits by labour inspectors are not announced, but some information about the construction site to be inspected is needed, as a minimum, the Prior Notice (referred to in subsection 4.1) and the Safety and Health Plan (referred to in subsection 9.1), and preferably also the Safety and Health File (also referred to in subsection 9.1).

These documents should list the main characteristics of the construction site, the hazards/risks and the corresponding preventive measures whose effective implementation is to be verified.

In view of this, the OSH law or regulations should make their presentation compulsory whenever the labour inspectorate requires it. While the Prior Notice should be sent to the authorities (e.g. labour inspectorates) for the construction projects with the conditions described in subsection 4.1, the Safety and Health Plan (SHP) and the Safety and Health File (SHF) should only be sent to the authorities when this is explicitly required.

The authorities may require these documents from any of those involved in the construction process, but preferably the owner/client. Requiring a SHP and a SHF means that the labour inspectorate should analyse it and decide whether or not an inspection should be performed. In view of this, requiring these documents for all construction projects is not at all recommended.

The selection of the SHP and SHF to be required may be based on the planning of the OSH inspection programme referred to in subsection 5.1, i.e. these documents should be required for the “high-risk” construction sites to be inspected during a period (e.g. 3 months).

Based on these documents (SHP and SHF), the labour inspectors may prepare the inspection of each of the construction sites following the process set out in a), below. It is based on checklists and on the evaluation method set out in b), below.

### a) Inspection process

A coordinator of the inspection should be appointed, who should prepare and conduct all activities before, during and after the inspection process. This process should include the following three main steps in a systematic way (Figure 44):

- preparation of the inspection;
- performing the inspection;
- reporting on the inspection.



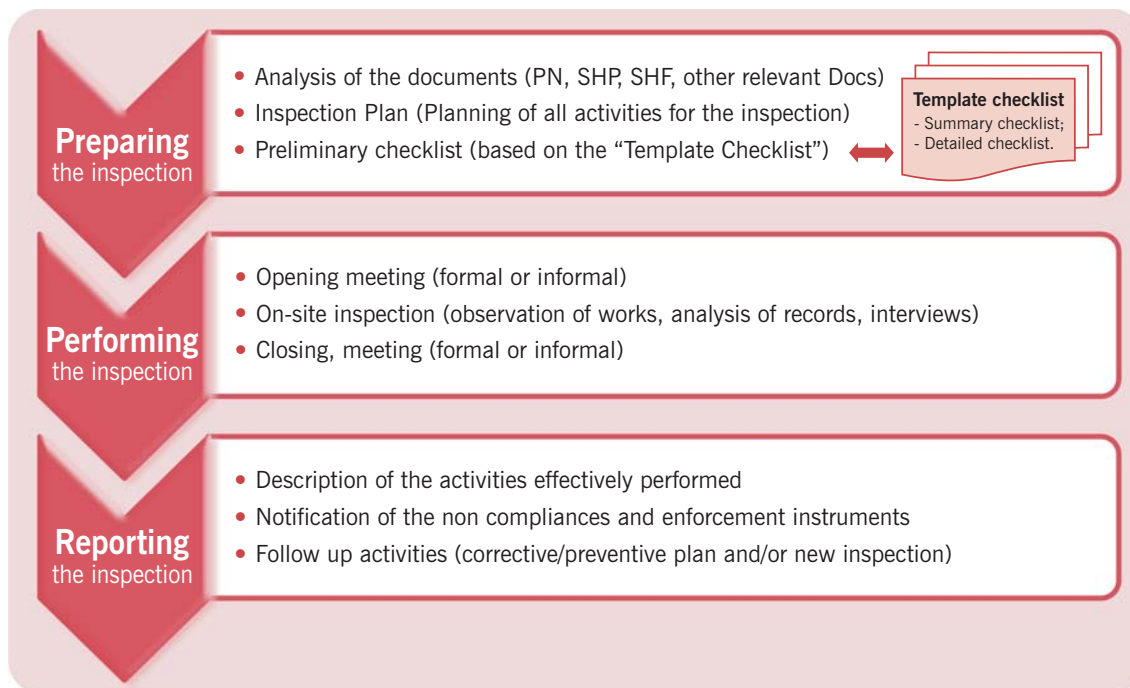

Figure 44 – Main steps of the inspection process of a construction site

The **preparation of the inspection** includes the compilation and analysis of all the relevant information related to the construction site (namely, the Prior Notice, the Safety and Health Plan, the Safety and Health File), the Inspection Plan and the checklists to be used as a reference.

The **Inspection Plan** (IP) is an internal document of the labour inspectorate that should be flexible to accommodate any changes during the inspection process. It should include the following information (see annex *a*) for an example):

- objectives of the inspection, which include the analysis of the implementation of the safety and health measures on the construction site, using a random sample;
- reference documents (e.g. laws and regulations, prior notice, safety and health plan, safety and health file, project design and specifications);
- scope of the inspection, including the parts or activities of the construction site to inspect;
- dates and places of the inspection;
- estimated timetable and duration of the inspection activities, including meetings;
- description of the functions/responsibilities of each member of the inspection team (coordinator, inspectors, assistants, technical experts, observers);
- identification of the main people responsible for the construction site (namely, owner's representative, constructor's representative, OSH experts);
- language to be used during the inspection (usually, the country's official language; the employers may need interpreters if they employ foreign workers);
- topics of the inspection report and estimated date for sending it to the owner's representative and/or to the constructor's representative (independently of this report, the labour inspectors may immediately apply any of the enforcement instruments referred to in subsection 9.1, especially the most severe ones);
- logistics issues (special transport for lengthy construction sites, e.g. roads, pipelines, and means needed to gather evidence like cameras, photocopiers, etc.);
- confidentiality (all documents gathered should be confidential, but the labour inspectorate may use them for legal prosecution, if need be);
- follow up action (e.g. follow up inspections, as per subsection 9.1).



Checklists should be prepared before the inspection. They should take into account the type of construction project and what is to be inspected.

The process of **performing the inspection**, i.e. the on-site activities, should be conducted according to the Inspection Plan. There should be an opening meeting, followed by on-site observations (gathering evidence) and finally a closing meeting. Records of attendance at all formal meetings during the inspection should be kept, especially for the opening and closing meetings.

The **opening meeting** may be formal or non formal. In very small construction projects, this meeting may involve only the identification of the labour inspector and the person responsible for the construction site (e.g. foreman). On the other cases, however, the opening meeting should be formal and should involve the main persons responsible for the construction site (owner's and constructor's representatives, OSH experts, but also the workers' representatives).

At a formal opening meeting, the coordinator of the inspection should summarise the way the inspection will be conducted, in line with the Inspection Plan, including<sup>14</sup>:

- introducing the inspection team and the main functions of each of its members, including the reasons for the inspection and the need to use the office during it;
- requirement the presence of the person in charge of the construction site according to the Inspection Plan; those not usually present on the construction site (e.g. the owner's representative) should be required at least for an interview and to attend the closing meeting;
- brief presentation of the objectives, scope and reference documents of the inspection;
- information on the Inspection Plan, introducing any changes needed;
- Information about the method and procedures that will be used for the inspection, pointing out that the inspection uses a random sample and so refers only to the activities observed; it should not be inferred that activities not observed comply with the reference documents;
- confirmation of the working language during the inspection; any foreign workers who do not speak the national language should be accompanied by someone working on the site who does;
- requiring the availability of any special resources needed for the inspection (e.g. special transport needed to inspect some parts of the construction site, access to photocopies of the documents and, if not available, the originals may be taken by the labour inspector during a short period not exceeding two working days, leaving a receipt of these documents);
- requiring safety and emergency procedures to be followed by the inspection team;
- information on conditions for ending the inspection (e.g. changes in weather);
- Confidentiality issues (all documents shall be available, except those that are protected by law as professional secret and a proof is presented).
- The on-site observations aim to gather the information that will confirm whether preventive measures are being taken as per the reference documents mentioned above. This information may be gathered in three ways:
  - observation of the work being done;
  - analysis of the documents recording the action taken;
  - interviewing the person in charge of the construction site and the workers' representatives.

The objective is to get evidence to support the inspection findings. Means include: (i) analysis and photocopying of relevant documents; (ii) observation and photographing or filming of relevant on-site activities and workplaces; (iii) verification of support equipment being used; and (iv) notes taken in interviews with workers involved in the on-site activities.

The **closing meeting** may be formal or non formal. In very small construction projects, this may involve only the communication of any non-compliance and recommendation (this may be done during the on-site activities), including the notification of any enforcement instrument.

<sup>14</sup> Depending on the size and complexity of each construction project, simplifications should be considered.



In large construction projects, the closing meeting should be formal and involve the people who attended the opening meeting, at which:

- the main conclusions (and any recommendation) should be presented;
- enforcement instruments should be applied if any non-compliance has been observed (confirming any verbal order made during the inspection); and
- any subsequent action should be stipulated, including the period of time for those responsible for the construction site to take any corrective or preventive action.
- Finally, an **inspection report** should be drawn up in the following days (preferably, within one week) by, or under the responsibility of, the coordinator of the inspection. This report should include (but not be limited to) the following items:
  - introduction;
  - objectives and scope of the inspection (confirming those referred to in the Inspection Plan);
  - identification of the construction site inspected (name, address, processes inspected, etc.);
  - actions performed (actual dates, places visited, meetings, etc.);
  - reference documents used in the inspection, highlighting those used most;
  - inspection checklists and findings;
  - conclusions and any recommendations.

All the information gathered during the inspection should be attached to the report, together with the Inspection Plan, the enforcement instruments issued during the inspection and any other relevant information.

#### b) Checklists and evaluation method

An inspection is a dynamic process. Consequently, the inspection evaluation should use, but not be limited to, a preliminary checklist in the form of a questionnaire. This preliminary checklist should be prepared by the labour inspectors based on a “template checklist” provided by the labour inspectorates, including the relative weighting of each item as a way to ensure uniformity among inspections. This “template checklist” should be periodically updated to be enriched along the time and used as an internal “standard”. However, the labour inspectors should be able to add items and/or adapt them to the specific features of each case while preparing the inspection and also during it.

An example of a “template checklist” for the inspection of construction sites is given in annexe b). It may be used in two levels (the process hereafter described is similar to that presented on subsection 4.2 - Method for selecting construction sites to be inspected):

- evaluation based on the summary checklist (1<sup>st</sup> level);
- evaluation based on the detailed checklist (2<sup>nd</sup> level).

The evaluation method based on the summary checklist (1<sup>st</sup> level) is simpler to use and analyse, as the number of items is small. It can be, however, more difficult to make a good assessment of each item in view of their broad scope.

To reduce subjectivity on the assessment, each item should be expanded into groups of sub-items. This means that a detailed checklist (2<sup>nd</sup> level) should be used instead. The results of the evaluations of each 2<sup>nd</sup> level group of sub-items should then be transferred to the corresponding 1<sup>st</sup> level item, i.e., to the summary checklist.

In both cases (1<sup>st</sup> and 2<sup>nd</sup> level evaluations), each item and sub-item should be weighted ( $W_i$  and  $W_k$ ) between 1 and 5 (with 1 meaning “least important” and 5 “most important” in terms of the potential risks involved), where  $W_i$  and  $W_k$  represent the weight of the item  $i$  from 1 to  $n$  (number of items considered) or of the sub-item  $k$  from 1 to  $m$  (number of sub-items considered). These weightings should be decided by the labour inspectorate following the procedure referred to in subsection 4.4 (where the items and sub-items correspond to the criteria and sub-criteria) and included in the template checklist mentioned above.

For each construction site, the data for each of these items should be analysed and an assessment made in terms of the potential risks involved. Two approaches may be used:

- assessment based on just “conform/comply” and “no conform/no comply”; or
- detailed assessment based on a rating system.

The first approach is simpler and may be used for external presentation. However, the second approach is recommended for internal use, as it gives information on the level of conformance/compliance of each item against the respective reference document, and it may be “transposed” into the first approach.

Where a detailed assessment based on a rating system is to be followed (second approach), the assessment of each item should be rated out ( $A_i$ ) between 0 (zero) and 5 (five), where  $A_i$  represents the assessment of the item  $i$ . Intermediate values may also be used by checking two consecutive  $A_i$  (e.g. checking the boxes 3 and 4 means an assessment of 3,5). The two approaches are equivalent where  $A_i$  is 0 or 5, respectively, for “no conform/no comply” and “conform/comply”.

Items rated less than 3 mean a “non-conformity/non-conformance” or “non-compliance”, with 0 meaning an “absolutely no”, “absolute non-conformity/non-conformance” or “absolute non-compliance”, and 1 and 2 meaning a “partial non-conformity/non-conformance” or “non-compliance” requiring a corrective and/or preventive action to be taken.

Items rated from 3 through 5 mean “conformity/conformance” or “compliance”, with 5 meaning an “absolutely yes”, “full conformity/conformance” or “full compliance”, and 3 or 4 mean a “partial conformity/conformance” or “partial compliance” and an opportunity for the labour inspectors to recommend improvements to those involved on the construction site (as part of a proactive approach). Figure 45 summarises this rating system to facilitate the task of those who have to apply it.

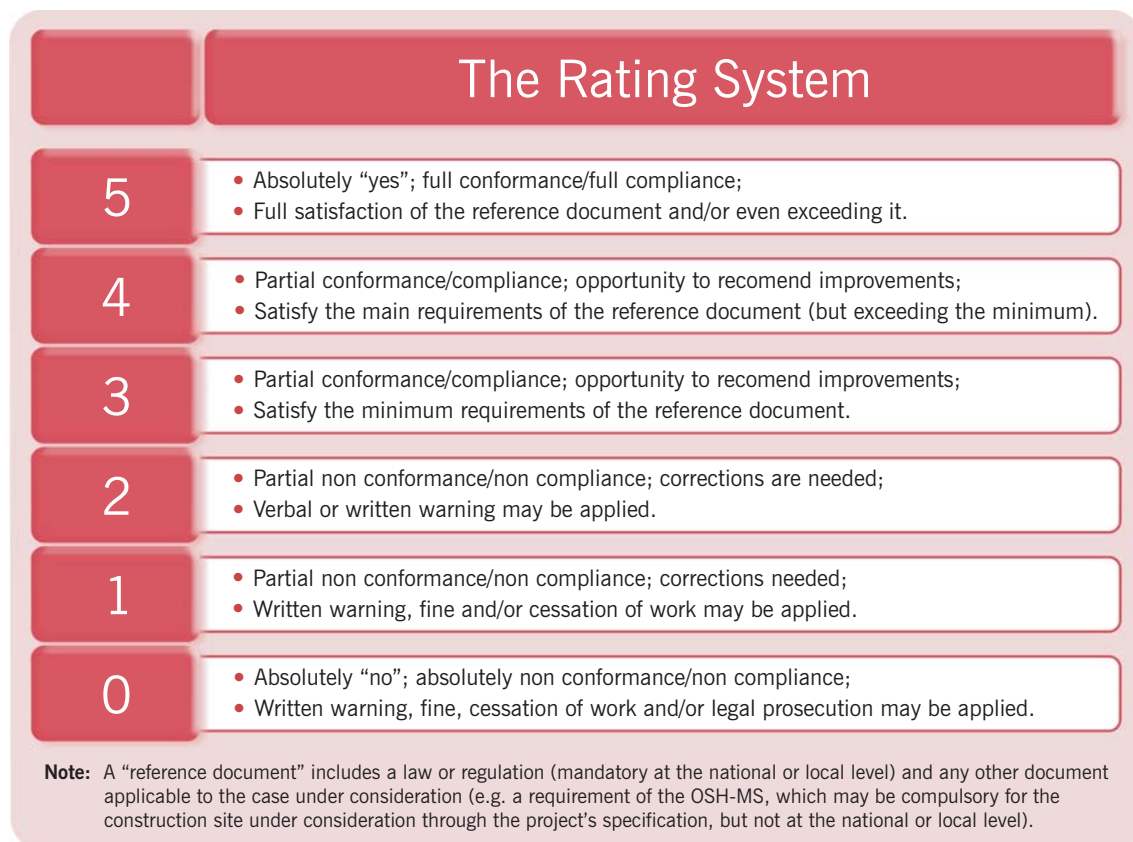

Figure 45 – The proposed rating system



The weighted evaluation of each item ( $E_i$ ) and the evaluation of the construction site ( $E$ ) in terms of a percentage (total weighted points obtained divided by the maximum possible points), are given by the following expressions, where “ $n$ ” is the number of items:

$$E_i = W_i \times A_i \quad (1) \quad E = \frac{\sum_{i=1}^n E_i}{5 \times \sum_{i=1}^n W_i} \quad (2)$$

The weighted evaluation of each second level item is obtained by the expression (3) below, and the weighted evaluation of each group of sub-items to be transferred to the corresponding first level item, is obtained by the expression (4), where “ $m$ ” is the number of sub-items of each group. These expressions are similar to those presented above, but using the letter “ $k$ ” instead of “ $i$ ” to mean the items of the second level, i.e. while  $W_i$  means the weight of item “ $i$ ” at the first level (summary checklist),  $W_k$  means the weight of item “ $k$ ” of the second level (detailed checklist).

$$E_k = W_k \times A_k \quad (3) \quad E_i = W_i \frac{\sum_{k=1}^m E_k}{5 \times \sum_{k=1}^m W_k} \quad (4)$$

On the other hand, as the model treats partial “non-conformity/conformance” and partial “non-compliance” (assessments other than 0 or 5) differently, we must explain the difference between these two concepts.

Whereas “non-conformity/conformance” is a failure to meet a requirement of, for example, a management system implemented on a voluntary basis (e.g. ILO-OSH 2001 or any other reference document), “non-compliance” is a failure to meet a requirement of a law or compulsory regulation (compulsory at the local or national level).

A national, regional or international standard is by nature non-compulsory. However, if a law makes a standard compulsory, then a failure to meet this standard is “non compliance”.

Moreover, although non-compliance is often just a matter of “comply/no comply”, there are many situations in the construction industry where intermediate values should be considered.

For example, in many countries the regulations lay down technical characteristics for temporary edge guardrail systems (height, top and intermediate guard-rails, toeboards, resistance, etc.) but on some construction sites there are guardrails that do not meet all these requirements (e.g. toeboards are missing). One can deem this partial non-compliance with the regulations, scoring it from 1 to 4 depending on the risks (e.g. those caused by the absence of toeboards).

In view of this, where the reference document for the item under consideration is a law or a regulation and a partial assessment  $A_i$  is checked (other than 0 or 5), then the model considers half of the weighted evaluation ( $E_i$ ). This works as a penalisation of the system due to non compliance with a law or regulation.

Table 15 shows an example of a “summary checklist” (1<sup>st</sup> level) for the evaluation of a construction site.

**Table 15: Summary checklist for the evaluation of a construction site (first level)**

Nr.	Checklist	Ref. DOCs <sup>(1)</sup>	W <sub>i</sub> <sup>(2)</sup> (1 - 5)	Assessment - A <sub>i</sub> <sup>(3)</sup>										Weighted Evaluation E <sub>i</sub> <sup>(4)</sup>	INFO Nr. <sup>(5)</sup>
				External		Internal									
				Law		C	NC	0	1	2	3	4	5		
1	Site organizational flowchart and human resources											X			
2	Safety and health coordination during the design phase (SHC-D)														
3	Safety and health coordination during the construction phase (SHC-C)														
4	Control of Prior Notice (PN)														
5	Control of the Safety and Health Plan (SHP)														
6	Control of the Safety and Health File (SHF)														
7	Planning and control of operations (bar chart)														
8	Site layout and facilities (including the construction workplaces)														
9	Control of site workers														
10	Control of site subcontractors														
11	Control of site machinery and accessories														
12	Work related accidents and diseases on the site, including investigations														
13	Emergency plan														
14	Audits, technical visits and official inspections performed on the site														
15	Site environmental control														
16	Monitoring and Prevention Plans (MPP)														
17	Records of non-conformities (NC) and corrective/preventive actions														
18	Control of excavations														
19	Control of trench lining systems														
20	Control of working scaffolds														
21	Control of temporary edge guardrails systems														
22	Control of safety nets														
23	Control of falsework														
24	Free														
25															
<b>Totals - &gt;</b>															—
				<b>Site Evaluation (E %):</b>											

Table 16 shows the detailed checklist (2<sup>nd</sup> level) for item 20 (control of working scaffolds) of the above checklist. These are also included in . This checklist is based on the European Union standards EN 12810 and EN 12811. The first position on this checklist is used to write the place where the working scaffold under checking is on the construction site, together with the base material used and whether it is prefabricated or not.

The second position is to be used for the classification of the scaffold according to the mentioned EN standards (service load class, drop test, width class, etc.). This is briefly described to in subsection 8.2. The following positions are then used to check evidence gathered during the inspection.



Table 16: Detailed checklist of the evaluation of a working scaffold (second level)

Nr.	Checklist	Ref. DOCs <sup>(1)</sup>	W <sub>s</sub> <sup>(2)</sup> (1 - 5)	Assessment - A <sub>s</sub> <sup>(3)</sup>							Weighted Evaluation E <sub>s</sub> <sup>(4)</sup>	INFO Nr. <sup>(5)</sup>	
				External		Internal							
				Law	C	NC	0	1	2	3			4
20	<b>Control of working scaffolds</b>												
	<b>Place of the scaffold and type</b> (façade, tour, etc.); <b>Base material</b> (steel, aluminium, wood, other); <b>Prefabricated</b> (only for h5,5 m) or <b>non-prefabricated</b> (any h):												
	<b>North façade; steel; prefabricated (h=18 m)</b>												
	<b>Classification/Designation:</b> Service load class (1-6); Without or with drop test (N, D); Width class (W06-W24); Headroom class (H1, H2); Without or with cladding (A, B); Vertical access with ladder, stairs or both (LA, ST, LS)	EN 12810; EN 12811											
	<b>Scaffold EN 12810 – 4D – SW09/250 – H2 – B - LA</b>												
	a) If prefabricated scaffold, clearness of the identification of the scaffold system and all its components, including manufacturer, year of manufacture or traceability code	EN 12810											
	b) If non-prefabricated scaffold, verification of the responsibility document of the designer of the scaffold and his official qualification for the design, as well as the verification of the inspection documents of the components of the scaffold and/or their marking.	EN 12811											
	c) Availability of the Product Manual in the country language, including the instructions for erection, use, modification and dismantling	EN 12810; EN 12811											
	d) Analysis of the test and assessment report of the scaffold made before use, performed by a different person from the designer, including the verification and record of the anchorages and foundations of the scaffold according to the loads of the design	EN 12810; EN 12811											
	e) General assessment of the scaffold on site before the first use, including the side protection which should have a principal (h=1 m) and intermediate guardrail (h/2) and toeboard (=0,15 m)	EN 12810; EN 12811											
	f) General assessment of the scaffold every 3 months and after any interruption on the use of the scaffold for more than one month												
	g) General assessment of the scaffold after any changing of its previous position on site and after any changing of the conditions of use (e.g. different loads)												
	h) General assessment of the scaffold after any accident or incident due to malfunction of the scaffold or following adverse atmospheric conditions												
	i)												
	j)												
	k)												

In these checklists (first and second level), “Nr.” means a reference number of the checklist and “Ref. DOCs” means the reference documents, which may be an article, requirement, item or clause of a law, regulation, standard, specification, or any other applicable document (mandatory to the case under consideration) against which the evaluation of the item is to be checked for conformity/conformance or compliance. Where a “X” is recorded in the “Law” column, it means that the reference document for the respective item is a law or a compulsory regulation and so the weighted evaluation of this item will consider the penalisation mentioned above.

The column labelled “INFO” may be used to record a reference number (e.g. sequential number) referring to a document that supports the evaluation (e.g., evidences gathered, notes, comments). Where an “X” is recorded in this column, it means that information or a statement of a fact had just been received but no evaluation or confirmation had been made, and so it will not be included in the evaluation.

Each construction site may have a significant number of items to check and so many others are to be added to the “template checklist” mentioned above (as part of the dynamic process), depending on the type of construction project and its characteristics (e.g. complexity).

Moreover, the user of this checklist may have to be an expert on the construction process with a knowledge of the laws, regulations and standards specific to the construction activity.

## Summary and conclusions

The construction industry is an economic activity that involves many interested parties and produces unique products (a building, a bridge, a road, etc.) unlike other industries, which turn out products in series. Moreover, different contracting approaches are used, and each of them should follow specific procedures that take the project's size, complexity and surrounding environment into account. Section 2 of this document accordingly covers key construction concepts and key OSH concepts.

These and many other features of this industry, addressed in section 3 of this document, make it a hazardous industry as is recognised by all those involved in it. Different hazards/risks are present in the daily activity as referred to in the section 7 of this document, which calls for more and more attention to the implementation of control and prevention measures, the main ones are covered in section 8. A knowledge of the construction processes is essential if we are to minimise the hazards/risks and to find new prevention measures.

Many countries have seen an effort at continuous improvement of working conditions and of safety and health measures by many construction enterprises and OSH experts, with fewer occupational accidents and diseases as a result. However, it is our belief that all the other parties involved in the construction process (namely, owners/clients, designers and managers) should make a bigger effort on these issues. They should recognise their own influence on the effective implementation of OSH measures in order to achieve the main objective, i.e., to reduce the number of occupational accidents and diseases in the construction industry continuously.

The owners/clients are the first party interested in the success of their construction projects and so they should bear all the costs, including those for OSH. They usually want a project to be built in a way that avoids having a harmful impact on the environment, and with an appropriate level of quality (avoiding both short-term and long-term defects) and of safety and health (avoiding occupational accidents and diseases among the workers who build and maintain the project), within the time scheduled and minimizing the costs involved. The traditional focus by many owners/clients on cost and time should be not encouraged in any way, and should never compromise OSH.

As most owners/clients do not know the construction process (they are not usually construction professionals), the designers and managers play a very important OSH role, as they are the "agents" of the owners/clients or constructors. They are professionals with construction knowledge, skills and responsibilities (during the design, execution and maintenance phases) and so they should stress the integration of OSH issues in their daily activity, as some of them already do in many countries.

From the point of view of OSH, a construction project can only be successful if all those involved in it shoulder their OSH burdens in an effective and proactive way. OSH laws and regulations should therefore include these responsibilities, while being consistent with the existing construction laws and regulations, and also taking the culture and practices of each country into consideration.

Because these laws and regulations have to be applied by different stakeholders, new laws or regulations should grade the requirements according to the size and complexity of each construction project, and should come into force only after those who have to implement them have had time to get information and training concerning the new arrangements. Failure to recognise the importance of this may lead to their not being applied in an effective and proactive way or, even worse, to their not being





credible in the short term. It is our belief that non-compliance with OSH laws or regulations may sometimes be explained by the importance of these details not being recognised.

While those involved in the construction process are responsible for implementing the OSH laws and regulations, the labour inspectorate (and other parties, depending on the laws and regulations in each country) is responsible for enforcing compliance with them, including the inspection of the workplaces.

Regarding compliance with the OSH-related laws and regulations, a method for selecting enterprises and sites to inspect is proposed in section 4 of this document. Section 5 describes an approach to planning, monitoring and evaluating an OSH inspection programme.

Sections 6 to 9 describes a methodology to perform the inspection of construction enterprises and sites in a systematic way, including the main OSH hazards/risks and control measures in the construction industry and the management of subcontractors.

The high number of OSH laws and regulations, and also of changes made to them in short periods of time, may also in part explain non-compliance with their requirements. This has been said by many construction professionals in surveys. It brings out the need to improve the quality of the laws and regulations in some countries and also to follow the example of countries that have brought together most of their OSH laws into a “labour code”.

Concerning technical legislation, some countries have brought in a performance-based approach, in which the laws mainly restrict themselves to setting targets, and leave it to the social partners to draw up practical documents with details of how to achieve those targets.

The advantage of this approach is that these details are provided by construction federations or associations together with the construction unions, i.e. by those who know the construction process, the hazards/risks involved and the prevention measures. Compliance with these documents, too, should be enforced by the labour inspectorate.

Some countries now provide information on how to comply with the requirements of the law. These informative documents (which should involve the social partners) may also provide an “official” clarification and interpretation of the law, unlike books, which reflect the interpretation of their authors. This procedure is strongly recommended, as part of a proactive approach.

These approaches to OSH legislation are important because most of the proposals in this document can only be effective if the national legislation includes certain essential requirements as, for example, the prior notice, the safety and health plan, and the safety and health file, which are addressed in subsections 4.1 and 9.1 of this document.

The systematic and effective implementation of occupational safety and health management systems (OSH-MS) based on ILO-OSH 2001 guidelines, if duly tailored to the construction industry and the provisions of ILO Convention No. 167 on safety and health in construction, can help enterprises with their in-house monitoring duties and facilitate external monitoring by the labour inspectorate.

Every country in the world should seek continuous improvement of working conditions. The workers are indeed the most valuable resource in any organisation. They must be kept not only alive but healthy as well, at any “cost”. An effective and proactive approach of the labour inspectorates surely contributes for this dignified objective, which involves a high human sense.

## References

- Alves Dias, Luis & Coble, R. (Editors) (1999): "Construction Safety Coordination in the European Union". CIB – W99. Rotterdam. The Netherlands.
- Alves Dias, Luis (2003): "Coordination of Safety and Health in Construction Work from Designing Stage to Maintenance Stage in European Countries". Tokio, Japan.
- Alves Dias, Luis and Fonseca, M. (1996): "Safety and Health Plan in Construction" (Portuguese version). Edited by IST-IDICT. Lisbon, Portugal.
- ANSI/AHIA Z10 (2005): American National Standard for "Occupational Health and Safety Management Systems". USA.
- European Agency for Safety and Health at Work (EASHW, 2004): "Building in Safety" – Bilbao Declaration following the "European Construction Safety Summit" of 22 November 2004. Bilbao, Spain.
- European Agency for Safety and Health at Work (EASHW, 2006): "Building in Safety – 2 Years After - Constructing for Safety & Health in Europe". Achievements of the Partners of the European Construction Safety Forum 2004 – 2006. Brussels 21 September 2006. Belgium.
- European Commission (1993): "Safety and Health in Construction". Luxembourg.
- European Union Directive 89/391/EEC (1989): "Introduction of measures to encourage improvements in the safety and health of workers at work". JOCE Nr. L 183.
- European Union Directive 92/57/EEC (1992): "Implementation of minimum safety and health requirements at temporary or mobile construction sites". JOCE Nr. L 245.
- ILO/IALI (2001): Joint International Symposium on "Labour Inspection and occupational safety and health management systems". Summary report. Düsseldorf, Germany. May 2001.
- International Labour Organisation – ILO (1988a): "Convention 167 on Safety and Health in Construction". Geneva, Switzerland.
- International Labour Organisation – ILO (1988b): "Recommendation 175 on Safety and Health in Construction". Geneva, Switzerland.
- International Labour Organisation – ILO (1992): "Safety and Health in Construction: ILO Code of Practice". Geneva, Switzerland.
- International Labour Organisation – ILO (1998) – Resolution III of the Sixteenth International Conference of Labour Statisticians. 6 to 15 of October 1998. Geneva, Switzerland.
- International Labour Organisation – ILO (2001a) - Guidelines on Occupational Safety and Health Management Systems (ILO/OSH 2001).
- International Labour Organisation – ILO (2001b): "The construction industry in the twenty first century: Its image, employment prospects and skill requirements". Tripartite Meeting on the Construction Industry. Geneva, Switzerland.
- International Organisation for Standardisation - ISO (2000a): Quality Management Systems – Requirements (ISO 9001:2000).



- International Organisation for Standardisation - ISO (2000b): Quality Management Systems – Guidelines for performance improvements (ISO 9004:2000).
- International Organisation for Standardisation - ISO (2003): Quality Management Systems – Guidelines for quality management in projects (ISO 10006:2003).
- International Organisation for Standardisation - ISO (2004): Environmental Management Systems – Requirements with guidance for use (ISO 14001:2004).
- International Organisation for Standardisation - ISO (2005): Quality Management Systems – Fundamentals and vocabulary (ISO 9000:2005).
- ISSA – Construction Section (2001a): “International Survey on Coordination of Safety and Health at Temporary or Mobile Construction Sites”. Paris, France.
- ISSA – Construction Section (2001b): “Occupational Safety and Health Management Systems in Construction (OSHMSinCONS) – International Survey”. Paris, France.
- Murie, Fione (2007); “Building Safety – An International Perspective”. Building and Woodworkers International (BWI), a federation of 350 trade unions. Article published in the “International Journal of Occupational and Environmental Health in Construction” of Jan/March 2007.
- Päivi Hämäläinen, Jukka Takala and Kaija Leena Saarela (2006): Methodology for the estimates on accidents: Global estimates of occupational accidents. Elsevier. Safety Science.
- Senior Labour Inspectors Committee (SLIC, 2004): “European Construction Campaign - Part II: 2004 - Urgency for improvement of working conditions in the construction industry.
- Valcárcel, Alberto (2002); “Comparing occupational safety and health (OSH) developments, in various countries, in the framework of economic globalisation”. ILO, June 2002. Geneva, Switzerland.
- Valcárcel, Alberto (2003); “Occupational safety and health management systems in the construction industry: The ILO approach (ILO-OSH 2001)”. CIB-W99. São Paulo, Brazil.



# Annexes





# Annexe a

## Example of an Inspection Plan for construction sites







	<b>INSPECTION OF A CONSTRUCTION SITE</b>	<b>Reference</b>
	<b>INSPECTION PLAN</b>	

<b>CONSTRUCTION SITE:</b>
<b>FULL ADDRESS:</b>

<b>1</b>	<b>OBJECTIVES OF THE INSPECTION</b>
	<i>To analyse, through of a random sample, the implementation of the safety and health measures on the construction site based on the reference documents referred to in hereafter, including, where appropriate, recommendations for the improvement of the OSH implemented on site.</i>

<b>2</b>	<b>REFERENCE DOCUMENTS</b>
	<i>Laws and regulations there are applicable to the construction site under inspection</i>
	<i>Prevention documents of hazards/risks specifically applicable (prior notice, safety and health plan and file)</i>
	<i>Specifications of the construction project, including the project design, in special, of the temporary equipment</i>
	<i>Other relevant documents related to the construction project</i>

<b>3</b>	<b>SCOPE OF THE INSPECTION SCOPE</b>
	<i>Construction site as a whole or, depending on its size, the construction of some of the main works under going during the inspection visit.</i>

<b>4</b>	<b>DATE AND PLACE OF THE INSPECTION</b>
	2008 - ... - ... (weekday)
	Place: <i>Installations of the main constructor at ...</i>

<b>5</b>	<b>TIMETABLE AND ESTIMATED DURATION OF THE INSPECTION ACTIVITIES</b>	<b>ATTENDEES</b>
	<b>Morning:</b>	
	09:00 – Opening meeting	IT; ORp; CRp; SExp; WRp.
	09:30 – Brief analysis of the construction site flowchart and of the plan of the works.	IT; ORp; CRp; SExp
	10:00 – Visit to the support site (technical and/or social installations) and/or to all or part of the construction works undergoing.	IT; ORp; CRp; SExp
	12:30 – Lunch break	
	<b>Afternoon:</b>	
	14:15 – Analysis of relevant documents, including records of the actions implemented.	IT; ORp; CRp; SExp
	16:15 – Interviewing the worker's representatives, if applicable	IT; WRp
	16:30 – Interviewing the Constructor's representative and his safety expert	IT; CRp; CSExp
	16:45 – Interviewing the Owner's representative and his safety expert, if applicable	IT; ORp; OSExp
	17:00 – Meeting of the inspection team	IT
	17:30 – Closing meeting	IT; ORp; CRp; SExp; WRp.
	18:00 – End of the inspection	

IT – Inspection team; ORp – Owner's representative; CRp – Constructor's representative (responsible for all the construction site); SExp – Safety experts (owner and constructor); CSExp – Constructor's safety expert; OSExp – Owner's safety expert; WRp – Worker's representatives.

**Notes:** (1) The IT may decide to join other persons to the inspection visit (e.g. inspectors on training, external experts, etc.); (2) The timetable may be adjusted in view of the inspection activities during the period.

<b>Prepared by:</b>	<b>Verified by:</b>	<b>Approved by:</b>
Date:	Date:	Date:



6	<b>INSPECTION TEAM AND ASSISTANTS</b>	<b>FUNCTION</b>	<b>RESPONSIBILITIES</b>
		Coordinator of the Inspection	To coordinate all the activities of the inspection and to perform all or part of the inspections.
		Inspectors	To assist the Inspection Coordinator performing part of the inspections, including, where there is no Assistant, control of the presences and the copies of the documents requested (evidences of the inspection).
		External experts	To help the Inspection Coordinator on the assessment of specific technical documents, where needed.
		Assistants	Control of the presences and the copies of the documents requested (evidences of the inspection).
	Observers	Follow up the activities of the inspection, without any active action.	
7	<b>IDENTIFICATION OF THE REPRESENTATIVES OF THE OWNER AND MAIN CONSTRUCTOR</b>		
	Owner's representative: (name and contact)		
	Constructor's representative: (name and contact)		
8	<b>LANGUAGE TO BE USED DURING THE INSPECTION</b>		
	The official language of the country. Any worker not speaking this language should be assisted by someone from the construction site who does, under the responsibility of the constructor.		
9	<b>INSPECTION REPORT</b>		
	The Inspection Report will include, namely the following sections: Introduction; Objectives and scope of the inspection; identification of the main responsible for the construction site; actions effectively performed (dates and places where the inspection was performed); Reference documents; Checklist and findings of the inspection; Written notifications (based on the enforcement instruments); Conclusions and, where appropriate, recommendations; Annexes (this inspection plan, records of presences, documentation gathered during the inspection as evidences, and other relevant documents).		
	The methods used for the evaluation of the construction site will follow the internal procedure of the Labour Inspectorate.		
	The report will be available for internal use only by 2008-...-...		
10	<b>LOGISTICS</b>		
	Availability of an "office" on the construction site for the meetings; means for photocopying the relevant records (evidences of the inspection); requirement of specific personnel protective equipment to go inside the construction site; means of transport from, to and within the construction site, where needed (e.g. long construction sites with difficult accesses, as new roads, railway infrastructures, etc.); ...		
11	<b>CONFIDENTIALITY</b>		
	All information related to the inspection are confidential, and may not be made public with the previous authorisation of the Labour Inspectorate.		
12	<b>FOLLOW UP ACTIONS</b>		
	The follow up actions will be decided during the inspection depending on the results of the findings and on the internal procedure of the Labour Inspectorate for this purpose. The following actions may be defined: presentation of a corrective and/or preventive plan by those involved on the construction site; re-inspection of the construction site within a defined period, if the number of non-compliances exceed the limits defined in the internal procedure of the Labour Inspectorate; any other action (e.g. confirmation of the implementation of the corrective and/or preventive actions by one of those involved on the construction site by another of them with no responsibility on the non-compliances recorded).		

**NOTE:** The constructor should prepare during the morning period of the inspection (while the Inspection Team visit the construction work) the following documents where data should be referred to the day before the inspection (copies of these documents should also be available):

Nominal flowchart of the construction site (A4 or A3 format), including the definition of functions (all functions performed on site and not only related to OSH) of all those with key-positions related to OSH issues on this construction site;

**Overall Planning of the Works**, preferably reduced to the A3 or A4 format (the one approved and under use) where the Follow-up vertical line should be drawn in red representing the actual situation of the works as for the date of the inspection;

**Prior Notice** updated;

List of all **employers and self-employed persons**, of the **workers' representatives** for this site and of the **clerk of works**, by fulfilling the following tables.

<Name of the construction site>

List of all those involved on the construction site as per the day before of the inspection

Employer or Self-employed person	Head-office (place)	Intervention <sup>(1)</sup>	Nr. of workers		Contractor <sup>(3)</sup>	Obs.
			Total	Night <sup>(2)</sup>		
1.						
2.						
3.						
...						
<b>Totals à</b>						

Nr. of SC	Nr. of LBSc	Nr. of EQSc	Nr. of ESS	Nr. SE	Other

- <sup>(1)</sup> Refer the type of intervention: SC – Sub-constructor; SE – Self-employed person; LBSc – Labour-only subcontractor; EQSc – Equipment subcontractor with operator; ESS – Service Supplier, e.g. topography, OSH, quality, environment, etc.), followed by the type of work on this site (e.g. SC-reinforced bars, SC – falsework, LBSc – diverse works, EQSc – earthworks; ESS – OSH services, etc.);
- <sup>(2)</sup> Number of workers that stay overnight on the construction site in dormitories or in other installations specifically addressed to them near the construction site.
- <sup>(3)</sup> Name of the contractor who subcontract (SC, LBSc, etc.) followed by the reference number of the employer or self-employed person referred to in the first column of this table (e.g. SC3 means the sub-constructor referenced in the first column as the number 3).

Workers' representatives as per the day before of the inspection

Name	Professional category	Employer
1.		
2.		
...		

Clerk of Works (general and of a group of construction works)

Name	G	1 <sup>st</sup>	2 <sup>nd</sup>	Group of construction works	Employer
1.					
2.					
...					

Note: G, 1<sup>st</sup> and 2<sup>nd</sup> - Category of the Clerk of work, respectively, general, first and second category.





## *Annexe b*

### **Example of checklist to inspect construction sites**





## Summary of the Evaluation of the Construction Site

Nr.	Checklist	Ref. DOCs <sup>(1)</sup>		W <sub>i</sub> <sup>(2)</sup> (1 - 5)	Assessment - A <sub>i</sub> <sup>(3)</sup>						Weighted Evaluation E <sub>i</sub> <sup>(4)</sup>	INFO Nr. <sup>(5)</sup>
					External		Internal					
					C	NC	0	1	2	3		
1	Site organizational flowchart and human resources											
2	Safety and health coordination during the design phase (SHC-D)											
3	Safety and health coordination during the construction phase (SHC-C)											
4	Control of Prior Notice (PN)											
5	Control of the Safety and Health Plan (SHP)											
6	Control of the Safety and Health File (SHF)											
7	Planning and control of operations (bar chart)											
8	Site layout and facilities (including the construction workplaces)											
9	Control of site workers											
10	Control of site subcontractors											
11	Control of site machinery and accessories											
12	Work related accidents and diseases on the site, including investigations											
13	Emergency plan											
14	Audits, technical visits and official inspections performed on the site											
15	Site environmental control											
16	Monitoring and Prevention Plans (MPP)											
17	Records of non-conformities (NC) and corrective/preventive actions											
18	Control of excavations											
19	Control of trench lining systems											
20	Control of working scaffolds											
21	Control of temporary edge guardrails systems											
22	Control of safety nets											
23	Control of falsework											
24	Free											
25	Free											
26	Free											
27	Free											
28	Free											
29	Free											
30	Free											
<b>Totals - &gt;</b>												—
											<b>Site Evaluation (E %):</b>	

**Main conclusions of the site evaluation:**

<sup>(1)</sup> Ref. DOCs = reference documents, which may be an article or clause of a law, standard, specification, etc.. If the Ref. DOC is a law or a regulation than this should be indicated ticking an "X" in the column "Law".

<sup>(2)</sup> W<sub>i</sub> = Weight of the item *i* rated between 1 and 5: W<sub>i</sub> = 1, means "least important"; W<sub>i</sub> = 5, means "absolutely important".

<sup>(3)</sup> A<sub>i</sub> = Assessment of each criteria *i* rated out between 0 and 5: A<sub>i</sub> = 0 means "absolutely no" or "non conformity/compliance"; A<sub>i</sub> = 5 means "absolutely yes" or "full conformity/compliance".

<sup>(4)</sup> E<sub>i</sub> = Weighted evaluation of each item *i*.

<sup>(5)</sup> INFO (Information) - A reference (sequential) number in this column means the reference to a document that supports the evaluation, e.g., evidences gathered, notes, comments, etc.. Where a "X" is recorded in this column, means that an information or a statement of a fact was just received but no evaluation or confirmation has been performed.

**The Coordinator of the Inspection**

\_\_\_\_\_  
 (Name, Position and Date)





## Detailed Evaluation of the Construction Site

**Notes:**

- (1) During the on-site observation of the works being performed, for a detailed investigation of conformity against the provisions of the law or regulations, it is important to identify, at least, one worker, one machine, one subcontractor, one construction operation and, where applicable, one of each of the main temporary protection equipment (guardrail, scaffold, safety net, working platform, lining system, etc.);
- (2) In this checklist,  $W_k$ ,  $A_k$  and  $E_k$  have the same meaning of their correspondents in the summary checklist above mentioned, but referred to the detailed evaluation ("second level items")

Nr.	Checklist	Ref. DOCs <sup>(1)</sup>		$W_k$ <sup>(2)</sup> (1 - 5)	Assessment - $A_k$ <sup>(3)</sup>						Weighted Evaluation $E_k$ <sup>(4)</sup>	INFO Nr. <sup>(5)</sup>	
		Law			External		Internal						
					C	NC	0	1	2	3			4
<b>1</b>	<b>Site organizational flowchart and human resources</b>				—	—	—	—	—	—	—		
a)	Suitability and sufficiency of the flowchart of management resources, including all those in the team at the management level on the site												
b)	Visibility of the place where the flowchart is posted to be seen by all the workers on site												
c)	Description of documented tasks to all those with OSH responsibilities at the management level on site (from the site manager to the craftsmen)												
d)	Documented identification and number of worker's representatives on site (consider the minimum number according to the law, if applicable)												
e)	Description of documented tasks for the worker's representatives and means provided to accomplish them												
f)	Control of human resources on site (list and number of workers on site subdivided on those under direct control of the Contractor and those of the subcontractors, list and number of subcontractors including subcontracting chain, self-employed workers, etc.)												
g)													
h)													
i)													
<b>2</b>	<b>Safety and health coordination during the design phase (SHC-D)</b>				—	—	—	—	—	—	—		
a)	Procedure to control the application of the general principles of prevention												
b)	Procedure to develop the safety and health plan carried on during the design phase												
c)	Procedure to develop the safety and health file carried on during the design phase												
d)													
e)													
f)													
<b>3</b>	<b>Safety and health coordination during the construction phase (SHC-C)</b>				—	—	—	—	—	—	—		
a)	Procedure to coordinate the application of the general principles of prevention when technical and/or organizational aspects are being decided, in order to plan the various items or stages of work which are to take place simultaneously or in succession												
b)	Procedure to coordinate the application of the general principles of prevention when estimating the period required for completing such work or work stages												
c)	Procedure to coordinate the accomplishment of the obligations of the employers and self-employed workers												
d)	Procedure to follow up the implementation of the safety and health plan												
e)	Procedure to make, or cause to be made, any adjustments required to the safety and health plan to take account of the progress of the work and any changes which have occurred												
f)	Procedure to make, or cause to be made, any adjustments required to the safety and health file to take account of the progress of the work and any changes which have occurred												



Nr.	Checklist	Ref. DOCs <sup>(1)</sup>	W <sub>x</sub> <sup>(2)</sup> (1 - 5)	Assessment - A <sub>x</sub> <sup>(3)</sup>										Weighted Evaluation E <sub>x</sub> <sup>(4)</sup>	INFO Nr. <sup>(5)</sup>
				External		Internal									
				C	NC	0	1	2	3	4	5				
g)	Procedure to organize the cooperation between employers, including successive employers on the same site, coordination of their activities with a view to protecting workers and preventing accidents and occupational health hazards and reciprocal information														
h)	Procedure to coordinate arrangements to check that the working procedures are being implemented correctly														
i)	Procedure to take the steps necessary to ensure that only authorized person are allowed onto the construction site														
j)															
k)															
l)															
<b>4</b>	<b>Control of Prior Notice (PN)</b>			—	—	—	—	—	—	—	—	—			
a)	Document in accordance with the regulations and maintained updated														
b)	Visibility of the place where the PN is posted to be seen by all the workers on site														
c)															
d)															
e)															
<b>5</b>	<b>Control of the Safety and Health Plan (SHP)</b>			—	—	—	—	—	—	—	—	—			
a)	SHP in accordance with the regulations														
b)	SHP is maintained updated														
c)	Availability of the SHP on site														
d)	SHP contains the risk evaluation and prevention measures for the works under construction that were observed during the audit														
e)															
f)															
g)															
<b>6</b>	<b>Control of the Safety and Health File (SHF)</b>			—	—	—	—	—	—	—	—	—			
a)	SHF in accordance with the regulations														
b)	SHF is maintained updated														
c)	Availability of the SHF on site														
d)															
e)															
f)															
<b>7</b>	<b>Planning and control of operations (bar chart)</b>			—	—	—	—	—	—	—	—	—			
a)	In general, the works are on schedule according to the planning														
b)	The works under construction and observed during the audit are on schedule														
c)	Manpower is being controlled based in bar chart, through progress curves or other tools														
d)	Machinery is being controlled based in bar chart, through progress curves or other tools														
n)															
o)															
p)															
<b>8</b>	<b>Site layout and facilities (including the construction workplaces)</b>			—	—	—	—	—	—	—	—	—			
a)	General appreciation of the site layout plan (presentation, details included, technical specifications and calculations of the different elements on site, etc.)														
b)	Access to site (conditions of the roads, signalling, etc.)														
c)	Fencing and gates (suitable for site security, covering the area of the construction site, site identification, etc.)														
d)	Internal circulation of workers and visitants, and site equipment (suitable of direction and OSH signalling, conditions of the internal roads, etc.)														
f)	Main office for the Contractor's staff (conditions of cleanliness, tidiness, natural and artificial illumination, ventilation, heating, fire extinguishers, etc.)														
g)	Dormitory/accommodation (layout according to the regulations, conditions of cleanliness, tidiness, natural and artificial illumination, ventilation, heating, fire extinguishers, etc.)														



Nr.	Checklist	Ref. DOCs <sup>(1)</sup>		W <sub>k</sub> <sup>(2)</sup> (1 - 5)	Assessment - A <sub>k</sub> <sup>(3)</sup>						Weighted Evaluation E <sub>k</sub> <sup>(4)</sup>	INFO Nr. <sup>(5)</sup>
		Law			External		Internal					
					C	NC	0	1	2	3		
h)	Mess huts and kitchens (layout according to the regulations and the number of workers that will use this facility, conditions of cleanliness, tidiness, natural and artificial illumination, ventilation, heating, fire extinguishers, OSH notices/advertisements, etc.)											
i)	Toilets (layout according to the regulations and the number of workers that will use this facility, conditions of cleanliness, tidiness, natural and artificial illumination, ventilation, heating, availability of hot water, etc.)											
j)	Cloak-rooms and showers and (layout according to the regulations and the number of workers that will use this facility, conditions of cleanliness, tidiness, natural and artificial illumination, ventilation, heating, availability of hot water, fire extinguishers, OSH notices/advertisements, etc.)											
k)	Basic facilities (water and electricity supply, drainage, garbage hermetic containers, etc.)											
l)	Other social facilities (Wash and drying, first aid rooms, social rooms for workers, where it is the case, fire extinguishers, etc.)											
m)	Car parking (delimitation, signalling, etc.)											
n)	Site stores for general materials (tidiness, cleanliness, etc.)											
o)	Site store for general tools (tidiness, cleanliness, etc.)											
p)	Timber or other formwork storage area and formwork preparation											
q)	Reinforcement storage and steel preparation											
r)	Concrete materials storage (aggregates, cement, etc.) and concrete mixer											
s)	Other storage areas (scaffolds, prefabricated materials, etc.)											
t)	Other areas for site equipment (tower cranes, etc.)											
u)	Order and tidiness of the site in general											
v)	Lighting of the site											
x)												
y)												
<b>9</b>	<b>Control of site workers</b>				—	—	—	—	—	—	—	
	Name; nationality; profession; employer:											
	(If more than one worker, identify all here and make the evaluation as a whole; or, for each worker, use also the extended checklist included below at the end)											
a)	Inclusion of the worker(s) in the general list(s) for control of site workers											
b)	Personal Protective Equipment (PPE) made available by the employer, including the suitability for the tasks performed by the worker(s), the maintenance conditions and the effective use of these PPE by the worker(s)											
c)	Information on risks made by the employer for the tasks performed by the worker(s)											
d)	Participation of the worker(s) in formal training or information programs on this site											
e)	Health control of the worker(s) according to the provisions and periodicity defined by law to assuring the physical and psychological aptitude of the worker(s) for the tasks performed											
f)	Control of alcoholism performed on this site according to the provisions of the law to the worker(s) and measures taken to prevent recurrence, if it is the case											
g)	Worker(s)'s coverage by the insurance against work accidents of their employer(s)											
h)	Integration of the worker(s) in the social security system											
i)	Number of working hours performed by the worker(s) according to the site planned working hours and to the law											
j)												
k)												
<b>10</b>	<b>Control of site subcontractors</b>				—	—	—	—	—	—	—	
	Name; activity (main task) on this site:											



Nr.	Checklist	Ref. DOCs <sup>(1)</sup>	W <sub>x</sub> <sup>(2)</sup> (1 - 5)	Assessment - A <sub>x</sub> <sup>(3)</sup>							Weighted Evaluation E <sub>x</sub> <sup>(4)</sup>	INFO Nr. <sup>(5)</sup>
				External		Internal						
				C	NC	0	1	2	3	4		
	(If more than one subcontractor, identify all here and make the evaluation as a whole; or, use also the extended checklist included below at the end for each subcontractor)											
a)	Inclusion of the subcontractor(s) in the general list(s) for control of site subcontractors											
b)	Suitability of the qualification of subcontractor(s) according to the law for the works being performed on this site											
c)	Suitability of the insurance against work accidents of the subcontractor's worker(s) covering the works being performed											
d)	Cooperation of the subcontractor(s) with the Contractor concerning OSH issues											
e)	Clear definition of the responsibility for the availability of PPE (for permanent use and for temporary use depending on the works to be performed) for the subcontractor's workers											
f)												
g)												
<b>11</b>	<b>Control of site machinery and accessories</b>			—	—	—	—	—	—	—		
	<b>Designation; model; year of fabrication; serial number; operator; working hours:</b>											
	(If more than one machine and/or accessory, identify all here and make the evaluation as a whole; or, for each one, use also the extended checklist included below at the end)											
a)	Inclusion of the machine(s) in the general list(s) for control of site machinery											
b)	Marking (e.g. EC), Conformity Declaration (issued by the fabricant and/or distributor) or other marking /conformity declaration accepted by law, as well as machinery insurance, instruction manual in the country language and other characteristics required by law.											
c)	Record of the updating of general periodic revisions and the updating of the maintenance actions, both recommended by the fabricant											
d)	General conditions of the machine, concerning apparent defects or other anomalies											
e)	Suitability of the qualification of the operator, including OSH training on site											
f)												
g)												
h)												
<b>12</b>	<b>Work related accidents and diseases on the site, including investigations</b>			—	—	—	—	—	—	—		
a)	Procedure to record work related accidents and diseases, including the confidence level and credibility of the data											
b)	Updating and divulgation (concerning visibility by all interest parties, namely the workers on site) of the records of work related accidents and diseases											
c)	Analysis of these records, including time evolution and, where possible, comparisons with other known similar cases											
d)	Analysis of on-site investigation reports, including measures taken to prevent the recurrence of similar cases											
e)												
f)												
<b>13</b>	<b>Emergency plan</b>			—	—	—	—	—	—	—		
a)	Procedure detailing the measures to be taken in case of emergency (severe accident, fire, earthquake, explosion, inundation, etc.), including evacuation plan											
b)	Divulgation of the emergency plan to emergency services (fire-brigade, rescue teams, other emergency services)											
c)	Divulgation and visibility of the emergency list of contacts on different areas of the site											
d)	First-aid services on site, including the number of on-site first-aid assistants and their distribution on the site (consider no more than the equivalent of 5 minutes distance to any working place on site)											



Nr.	Checklist	Ref. DOCs <sup>(1)</sup>	W <sub>k</sub> <sup>(2)</sup> (1 - 5)	Assessment - A <sub>k</sub> <sup>(3)</sup>							Weighted Evaluation E <sub>k</sub> <sup>(4)</sup>	INFO Nr. <sup>(5)</sup>
				External		Internal						
				C	NC	0	1	2	3	4		
e)												
f)												
<b>14</b>	<b>Audits, technical visits and official inspections performed on the site</b>			—	—	—	—	—	—	—		
a)	Procedure to perform internal audits and records of the implementation on the site, including, if applicable, corrective and/or preventive actions implemented											
b)	Procedure to perform technical visits and records of the implementation on the site, including, if applicable, corrective and/or preventive actions implemented											
c)	Measures implemented following second part audits on the site (e.g. owner, supervisor, safety and health coordinator), including corrective and/or preventive actions implemented, if it is the case											
d)	Measures implemented following official inspections on the site (e.g. Labour Inspectorates), if it is the case											
e)	Measures implemented following third part audits on the site (e.g. External Entity that granted the recognition of the system of the organization), if it is the case											
f)												
g)												
<b>15</b>	<b>Site environmental control</b>			—	—	—	—	—	—	—		
a)	Procedure to control noise and records of the implementation on site including, if applicable, corrective and/or preventive actions implemented											
b)	Procedure to control dust and records of the implementation on site including, if applicable, corrective and/or preventive actions implemented											
c)	Procedure to control fumes and records of the implementation on site including, if applicable, corrective and/or preventive actions implemented											
d)												
e)												
<b>16</b>	<b>Monitoring and Prevention Plans (MPP)</b>			—	—	—	—	—	—	—		
	<b>Designation of the activity; place of the activity on site:</b>											
	(If more than one activity (e.g. construction operation), identify all here and make the evaluation as a whole; or, for each one, use also the extended checklist included below)											
a)	Procedure for the development of MPPs, including the definition of responsibilities for the preparation, verification, approval and implementation (records of evidences)											
b)	Inclusion of the activity(ies) under consideration in the general list(s) of MPP for control of site activities											
c)	Preparation and approval of the MPP before starting the activity(ies) under consideration											
d)	MPP includes the main hazards and prevention measures in view of specific conditions to perform the activity(ies) and the surrounding environment											
e)	Records generated by the implementation of the MPP are kept updated and organised											
f)												
g)												
<b>17</b>	<b>Records of non-conformities (NC) and corrective/preventive actions</b>			—	—	—	—	—	—	—		
	<b>Designation of the non-conformity; place of the activity on site, if applicable:</b>											
	(If more than one record of non-conformity, identify all here and make the evaluation as a whole; or, for each one, use also the extended checklist included below)											
a)	Procedure for recording and organisation of non-conformities, including the definition of responsibilities for releasing, proposal and approval of corrective and/or preventive actions, implementation of the actions approved and final verification and approval of the record of non-conformity, as well as closing and archive of the non-conformity											
b)	Analysis of the non-conformities released by the second (e.g. Owner, Supervisor) or third part (external entity) instead of being released by the first part (e.g. Contractor) as a result of its auto control.											



Nr.	Checklist	Ref. DOCs <sup>(1)</sup>	W <sub>x</sub> <sup>(2)</sup> (1 - 5)	Assessment - A <sub>x</sub> <sup>(3)</sup>							Weighted Evaluation E <sub>x</sub> <sup>(4)</sup>	INFO Nr. <sup>(5)</sup>
				External		Internal						
				C	NC	0	1	2	3	4		
c)	Analysis of the record(s) of non-conformity under consideration and its consistency based on the procedure above mentioned, including the suitability of the corrective and/or preventive actions to be implemented or already implemented											
d)												
e)												
<b>18</b>	<b>Control of excavations</b>			—	—	—	—	—	—			
	<b>Place of the excavation; Deep</b> (in m); <b>Slope</b> (in degrees related to horizontal line): <b>(Note:</b> If a lining system is being used, it should be assessed separately):											
a)	Before starting the excavation, identification of existing infrastructure and actions taken to prevent accidents (their replacement to out of the area or signing them keeping a safety area of 1,50 meters for both sides)											
b)	Assessment of the adequacy of the slope taking into account the earth conditions (reference natural slope, existence of water, loose materials, etc.)											
c)	Assessment of the excavation plan, including the excavation phases, the methods of excavation, the transport and the final destiny of the materials from the excavation, etc..											
d)	Assessment of the actions taken to keep a safety area of half the deep of the trench (or another documented distance) for both sides											
e)	Assessment of the actions taken to prevent loose materials to roll into the trench from the slope and from the top of the trench (a protection of at least 0,15 m over the top of the trench on both sides should be considered)											
e)	Assessment of the means used by the workers to oeboa the trench (maximum distance of 15 meters)											
f)												
g)												
<b>19</b>	<b>Control of trench lining systems</b>			—	—	—	—	—	—			
	<b>Place of the lining system; Base material</b> (steel, aluminium, wood, other); <b>Prefabricated or non-prefabricated; Deep</b> (in meters):											
	<b>Classification/Designation</b> (if prefabricated): System type (CS, ES, RS, RD, RT, DB); Module (B, T, X); Strut type (SV, SI, SN, FR); Type of connection strut/panel (A, C, F); Length of slide rail (meters or XX); Panel in m (length x height x thickness); Internal trench lining width range in m (min/max); Bottom strut clearance in m (min/max); Characteristic system resistance range in kN/m2 (max/min, = 30); Mass in t (min/max)											
a)	If prefabricated, clearness of the identification of the lining system and all its components, including manufacturer, year of manufacture or traceability code											
b)	If non-prefabricated, verification of the responsibility document of the designer of the lining system and his official qualification for the design, as well as the verification of the inspection documents of the components of the lining system; if it is the case, declaration of conformity of the lining system with the technical specifications of the law, including the calculations assuring this conformity.											
c)	Availability of the Instructions Manual and the declaration of conformity of the manufacturer, both in the country language											
d)	General assessment of the lining system before the first use and after any changing of its previous position on site and after any changing of the conditions of use (e.g. different loads due to different deeps or conditions of the stability of vertical trench walls)											
e)	General assessment of the lining system every 3 months and before the reuse of the system if it is left in the trench for more than one week											





Nr.	Checklist	Ref. DOCs <sup>(1)</sup>		W <sub>k</sub> <sup>(2)</sup> (1 - 5)	Assessment - A <sub>k</sub> <sup>(3)</sup>						Weighted Evaluation E <sub>k</sub> <sup>(4)</sup>	INFO Nr. <sup>(5)</sup>
		Law			External		Internal					
					C	NC	0	1	2	3		
f)	Assessment of the position of the lining system in the trench (at least 0,15 m over the top of the trench) and the actions taken to keep a safety area of half the deep of the trench (or another documented distance) for both sides											
g)	Assessment of the means used to place and remove the lining system in/out of the trench, including the adequacy of the equipment used and any accessories (e.g. slings)											
h)	Assessment of the means used by the workers to oeboa the trench (maximum distance of 15 meters)											
i)												
j)												
<b>20</b>	<b>Control of working scaffolds</b>				—	—	—	—	—	—		
	<b>Place of the scaffold and type</b> (façade, tour, etc.); <b>Base material</b> (steel, aluminium, wood, other); <b>Prefabricated</b> (only for h5,5 m) <b>or non-prefabricated</b> (any h):											
	<b>Classification/Designation:</b> Service load class (1-6); Without or with drop test (N, D); Width class (W06-W24); Headroom class (H1, H2); Without or with cladding (A, B); Vertical access with ladder, stairs or both (LA, ST, LS)											
a)	If prefabricated scaffold, clearness of the identification of the scaffold system and all its components, including manufacturer, year of manufacture or traceability code											
b)	If non-prefabricated scaffold, verification of the responsibility document of the designer of the scaffold and his official qualification for the design, as well as the verification of the inspection documents of the components of the scaffold and/or their marking.											
c)	Availability of the Product Manual in the country language, including the instructions for erection, use, modification and dismantling											
d)	Analysis of the test and assessment report of the scaffold made before use, performed by a different person from the designer, including the verification and record of the anchorages and foundations of the scaffold according to the loads of the design											
e)	General assessment of the scaffold on site before the first use, including the side protection which should have a principal (h=1 m) and intermediate guardrail (h/2) and toeboard (=0,15 m)											
f)	General assessment of the scaffold every 3 months and after any interruption on the use of the scaffold for more than one month											
g)	General assessment of the scaffold after any changing of its previous position on site and after any changing of the conditions of use (e.g. different loads)											
h)	General assessment of the scaffold after any accident or incident due to malfunction of the scaffold or following adverse atmospheric conditions											
i)												
j)												
<b>21</b>	<b>Control of temporary edge guardrails systems</b>				—	—	—	—	—	—		
	<b>Place of the guardrail system; Material of posts</b> (steel, aluminium, wood, other); <b>Material of guardrails and oeboard; Guardrail class</b> (A, B, C); <b>Guardrail height:</b>											
a)	If prefabricated guardrail, clearness of the identification (marking) of the guardrail system and all its components, including manufacturer, year of manufacture or traceability code											
b)	If non-prefabricated guardrail, verification of the responsibility document of the designer of the guardrail and his official qualification for the design, as well as the verification of the inspection documents of the components of the guardrail and/or their marking.											
c)	Availability of the Product Manual in the country language, including the instructions for assembling, fixing to the structure and dismantling											



Nr.	Checklist	Ref. DOCs <sup>(1)</sup>	W <sub>s</sub> <sup>(2)</sup> (1 - 5)	Assessment - A <sub>s</sub> <sup>(3)</sup>							Weighted Evaluation E <sub>s</sub> <sup>(4)</sup>	INFO Nr. <sup>(5)</sup>
				External		Internal						
				C	NC	0	1	2	3	4		
d)	Analysis of the assessment report of the guardrail system made before use, performed by a different person from the designer											
e)	General assessment of the guardrail system on site before the first use, including the fixings to the structure											
f)	General assessment of the guardrail every 3 months											
g)	General assessment of the guardrail after any changing of its previous position on site											
h)	General assessment of the guardrail after any accident or incident due to malfunction of the guardrail or following adverse atmospheric conditions											
i)												
j)												
<b>22</b>	<b>Control of safety nets</b>			—	—	—	—	—	—	—		
	<b>Place of the safety net; Base material of support</b> (steel, aluminium, wood, other); <b>Prefabricated or non-prefabricated:</b>											
	<b>Classification/Designation:</b> Net system (S, T, U, V); Net class (A1, A2, B1, B2); Mesh configuration and size (Q#, D#); Net size in m (width x length); Inspection level of production (L, M)											
a)	If prefabricated safety net, clearness of the identification of the safety net and all its components (permanent marking and labelling), including manufacturer, net designation, identification number of the test mesh, year and month of manufacture or traceability code; minimum energy absorption, manufacturer article code.											
b)	If non-prefabricated safety net, verification of the responsibility document of the designer of the safety net and his official qualification for the design, as well as the verification of the inspection documents of the components of the safety net											
c)	Availability of the Instructions Manual in the country language and declaration of conformity, including the instructions for installation, use and dismantling, storage, care and inspection, conditions for withdrawal from service, any hazards warning (e.g. extreme temperature)											
d)	Analysis of the test and assessment report of the safety net made before use, performed by a different person from the designer, including the verification and record of the anchorages according to the loads of the design											
e)	General assessment of the safety net every 3 months and before the reuse of the safety net if it is left in the site unused for more than one month											
f)	General assessment of the safety net after any changing of its previous position on site and after any changing of the conditions of use (e.g. different anchorages) or an important repairing.											
g)	General assessment of the scaffold after any accident or incident due to a fall of a person or an object or following adverse atmospheric conditions (namely, extreme temperatures during a long period)											
h)												
i)												
j)												
k)												
<b>23</b>	<b>Control of falsework</b>			—	—	—	—	—	—	—		
	<b>Place of the falsework; Material</b> (steel, aluminium, wood, other); <b>Safework class</b> (A, B1, B2); Note: Class A may only be used for simple constructions (slabs and beams) if: a) cross-sectional area of slabs not exceeding 0,30 m <sup>2</sup> per metre width of slab; b) cross-sectional of beams are not exceeding 0,50 m <sup>2</sup> ; c) clear span of beams and slabs not exceeding 6,0 m; d) height to the underside of the permanent structure not exceeding 3,5 m).											



Nr.	Checklist	Ref. DOCs <sup>(1)</sup>		W <sub>k</sub> <sup>(2)</sup> (1 - 5)	Assessment - A <sub>k</sub> <sup>(3)</sup>						Weighted Evaluation E <sub>k</sub> <sup>(4)</sup>	INFO Nr. <sup>(5)</sup>
		Law			External		Internal					
					C	NC	0	1	2	3		
a)	Verification of the responsibility document of the designer of the falsework and his official qualification for the design, as well as the verification of the inspection documents of the components of the falsework and/or their marking.											
b)	Verification of the stability of the base support of the falsework											
c)	General assessment of the falsework after erection on site and before each use											
d)	General assessment of the falsework every week and after any interruption on the use of the falsework											
e)	General assessment of the falsework after any changing of its previous position on site and after any changing of the conditions of use (e.g. different loads)											
f)	General assessment of the falsework after any accident or incident due to malfunction of the falsework or following adverse atmospheric conditions											
g)												
h)												
i)												
<b>24</b>	<b>Free</b>				—	—	—	—	—	—		
a)												
b)												
c)												
d)												
e)												
<b>25</b>	<b>Free</b>				—	—	—	—	—	—		
a)												
b)												
c)												
d)												
e)												
<b>26</b>	<b>Free</b>				—	—	—	—	—	—		
a)												
b)												
c)												
d)												
e)												
<b>27</b>	<b>Free</b>				—	—	—	—	—	—		
a)												
b)												
c)												
d)												
e)												
<b>28</b>	<b>Free</b>				—	—	—	—	—	—		
a)												
b)												
c)												
d)												
e)												
<b>29</b>	<b>Free</b>				—	—	—	—	—	—		
a)												
b)												
c)												
d)												
e)												
<b>30</b>	<b>Free</b>				—	—	—	—	—	—		
a)												
b)												
c)												
d)												
e)												





## *Annexe c*

# **ILO Convention C167 on Safety and Health in Construction, 1988**





## C167 Safety and Health in Construction Convention, 1988

(ratified by 23 countries, as for April 2009)

Convention concerning Safety and Health in Construction

(Note: Date of coming into force: 11:01:1991)

Convention: C167; Place: Geneva; Session of the Conference: 75;

Date of adoption: 20:06:1988

The General Conference of the International Labour Organisation, Having been convened at Geneva by the Governing Body of the International Labour Office, and having met in its Seventy-fifth Session on 1 June 1988, and Noting the relevant international labour Conventions and Recommendations and, in particular, the Safety Provisions (Building) Convention and Recommendation, 1937, the Co-operation in Accident Prevention (Building) Recommendation, 1937, the Radiation Protection Convention and Recommendation, 1960, the Guarding of Machinery Convention and Recommendation, 1963, the Maximum Weight Convention and Recommendation, 1967, the Occupational Cancer Convention and Recommendation, 1974, the Working Environment (Air Pollution, Noise and Vibration) Convention and Recommendation, 1977, the Occupational Safety and Health Convention and Recommendation, 1981, the Occupational Health Services Convention and Recommendation, 1985, the Asbestos Convention and Recommendation, 1986, and the list of occupational diseases as revised in 1980 appended to the Employment Injury Benefits Convention, 1964, and Having decided upon the adoption of certain proposals with regard to safety and health in construction, which is the fourth item on the agenda of the session, and Having determined that these proposals shall take the form of an international Convention revising the Safety Provisions (Building) Convention, 1937, adopts the twentieth day of June of the year one thousand nine hundred and eighty-eight, the following Convention, which may be cited as the Safety and Health in Construction Convention, 1988:

### I. Scope and Definitions

#### Article 1

1. This Convention applies to all construction activities, namely building, civil engineering, and erection and dismantling work, including any process, operation or transport on a construction site, from the preparation of the site to the completion of the project.
2. A Member ratifying this Convention may, after consultation with the most representative organisations of employers and workers concerned, where they exist, exclude from the application of the Convention, or certain provisions thereof, particular branches of economic activity or particular undertakings in respect of which special problems of a substantial nature arise, on condition that a safe and healthy working environment is maintained.
3. This Convention also applies to such self-employed persons as may be specified by national laws or regulations.

#### Article 2

For the purpose of this Convention:

(a) The term *construction* covers:

- (i) building, including excavation and the construction, structural alteration, renovation, repair, maintenance (including cleaning and painting) and demolition of all types of buildings or structures;
- (ii) civil engineering, including excavation and the construction, structural alteration, repair, maintenance and demolition of, for example, airports, docks, harbours, inland waterways, dams, river and avalanche and sea defence works, roads and highways, railways, bridges, tunnels, viaducts and works related to the provision of services such as communications, drainage, sewerage, water and energy supplies;



- (iii) the erection and dismantling of prefabricated buildings and structures, as well as the manufacturing of prefabricated elements on the construction site;
- (b) the term *construction site* means any site at which any of the processes or operations described in subparagraph (a) above are carried on;
- (c) the term *workplace* means all places where workers need to be or to go by reason of their work and which are under the control of an employer as defined in subparagraph (e) below;
- (d) the term *worker* means any person engaged in construction;
- (e) the term *employer* means:
  - (i) any physical or legal person who employs one or more workers on a construction site; and
  - (ii) as the context requires, the principal Contractor, the Contractor or the subcontractor;
- (f) the term *competent person* means a person possessing adequate qualifications, such as suitable training and sufficient knowledge, experience and skill for the safe performance of the specific work. The competent authorities may define appropriate criteria for the designation of such persons and may determine the duties to be assigned to them;
- (g) the term *scaffold* means any temporary structure, fixed, suspended or mobile, and its supporting components which is used for supporting workers and materials or to gain access to any such structure, and which is not a lifting appliance as defined in subparagraph (h) below;
- (h) the term *lifting appliance* means any stationary or mobile appliance used for raising or lowering persons or loads;
- (i) the term *lifting gear* means any gear or tackle by means of which a load can be attached to a lifting appliance but which does not form an integral part of the appliance or load.

## II. General Provisions

### Article 3

The most representative organisations of employers and workers concerned shall be consulted on the measures to be taken to give effect to the provisions of this Convention.

### Article 4

Each Member which ratifies this Convention undertakes that it will, on the basis of an assessment of the safety and health hazards involved, adopt and maintain in force laws or regulations which ensure the application of the provisions of the Convention.

### Article 5

1. The laws and regulations adopted in pursuance of Article 4 above may provide for their practical application through technical standards or codes of practice, or by other appropriate methods consistent with national conditions and practice.
2. In giving effect to Article 4 above and to paragraph 1 of this Article, each Member shall have due regard to the relevant standards adopted by recognised international organisations in the field of standardisation.

### Article 6

Measures shall be taken to ensure that there is co-operation between employers and workers, in accordance with arrangements to be defined by national laws or regulations, in order to promote safety and health at construction sites.



**Article 7**

National laws or regulations shall require that employers and self-employed persons have a duty to comply with the prescribed safety and health measures at the workplace.

**Article 8**

1. Whenever two or more employers undertake activities simultaneously at one construction site-
  - (a) the principal Contractor, or other person or body with actual control over or primary responsibility for overall construction site activities, shall be responsible for co-ordinating the prescribed safety and health measures and, in so far as is compatible with national laws and regulations, for ensuring compliance with such measures;
  - (b) in so far as is compatible with national laws and regulations, where the principal Contractor, or other person or body with actual control over or primary responsibility for overall construction site activities, is not present at the site, he shall nominate a competent person or body at the site with the authority and means necessary to ensure on his behalf co-ordination and compliance with the measures, as foreseen in subparagraph (a) above;
  - (c) each employer shall remain responsible for the application of the prescribed measures in respect of the workers placed under his authority.
2. Whenever employers or self-employed persons undertake activities simultaneously at one construction site they shall have the duty to co-operate in the application of the prescribed safety and health measures, as may be specified by national laws or regulations.

**Article 9**

Those concerned with the design and planning of a construction project shall take into account the safety and health of the construction workers in accordance with national laws, regulations and practice.

**Article 10**

National laws or regulations shall provide that workers shall have the right and the duty at any workplace to participate in ensuring safe working conditions to the extent of their control over the equipment and methods of work and to express views on the working procedures adopted as they may affect safety and health.

**Article 11**

National laws or regulations shall provide that workers shall have the duty to-

- (a) co-operate as closely as possible with their employer in the application of the prescribed safety and health measures;
- (b) take reasonable care for their own safety and health and that of other persons who may be affected by their acts or omissions at work;
- (c) use facilities placed at their disposal and not misuse anything provided for their own protection or the protection of others;
- (d) report forthwith to their immediate supervisor, and to the workers' safety representative where one exists, any situation which they believe could present a risk, and which they cannot properly deal with themselves;
- (e) comply with the prescribed safety and health measures.

**Article 12**

1. National laws or regulations shall provide that a worker shall have the right to remove himself from danger when he has good reason to believe that there is an imminent and serious danger to his safety or health, and the duty so to inform his supervisor immediately.



2. Where there is an imminent danger to the safety of workers the employer shall take immediate steps to stop the operation and evacuate workers as appropriate.

### III. Preventive and Protective Measures

#### Article 13 - Safety of Workplaces

1. All appropriate precautions shall be taken to ensure that all workplaces are safe and without risk of injury to the safety and health of workers.
2. Safe means of access to and egress from all workplaces shall be provided and maintained, and indicated where appropriate.
3. All appropriate precautions shall be taken to protect persons present at or in the vicinity of a construction site from all risks which may arise from such site.

#### Article 14 - Scaffolds and Ladders

1. Where work cannot safely be done on or from the ground or from part of a building or other permanent structure, a safe and suitable scaffold shall be provided and maintained, or other equally safe and suitable provision shall be made.
2. In the absence of alternative safe means of access to elevated working places, suitable and sound ladders shall be provided. They shall be properly secured against inadvertent movement.
3. All scaffolds and ladders shall be constructed and used in accordance with national laws and regulations.
4. Scaffolds shall be inspected by a competent person in such cases and at such times as shall be prescribed by national laws or regulations.

#### Article 15 - Lifting Appliances and Gear

1. Every lifting appliance and item of lifting gear, including their constituent elements, attachments, anchorages and supports, shall-
  - (a) be of good design and construction, sound material and adequate strength for the purpose for which they are used;
  - (b) be properly installed and used;
  - (c) be maintained in good working order;
  - (d) be examined and tested by a competent person at such times and in such cases as shall be prescribed by national laws or regulations; the results of these examinations and tests shall be recorded;
  - (e) be operated by workers who have received appropriate training in accordance with national laws and regulations.
2. No person shall be raised, lowered or carried by a lifting appliance unless it is constructed, installed and used for that purpose in accordance with national laws and regulations, except in an emergency situation in which serious personal injury or fatality may occur, and for which the lifting appliance can be safely used.

#### Article 16 - Transport, Earth-Moving and Materials-Handling Equipment

1. All vehicles and earth-moving or materials-handling equipment shall-
  - (a) be of good design and construction taking into account as far as possible ergonomic principles;
  - (b) be maintained in good working order;
  - (c) be properly used;
  - (d) be operated by workers who have received appropriate training in accordance with national laws and regulations.

2. On all construction sites on which vehicles, earth-moving or materials-handling equipment are used-
  - (a) safe and suitable access ways shall be provided for them; and
  - (b) traffic shall be so organised and controlled as to secure their safe operation.

#### **Article 17 - Plant, Machinery, Equipment and Hand Tools**

1. Plant, machinery and equipment, including hand tools, both manual and power driven, shall-
  - (a) be of good design and construction, taking into account as far as possible ergonomic principles;
  - (b) be maintained in good working order;
  - (c) be used only for work for which they have been designed unless a use outside the initial design purposes has been assessed by a competent person who has concluded that such use is safe;
  - (d) be operated by workers who have received appropriate training.
2. Adequate instructions for safe use shall be provided where appropriate by the manufacturer or the employer, in a form understood by the users.
3. Pressure plant and equipment shall be examined and tested by a competent person in cases and at times prescribed by national laws or regulations.

#### **Article 18 - Work at Heights Including roofwork**

1. Where necessary to guard against danger, or where the height of a structure or its slope exceeds that prescribed by national laws or regulations, preventive measures shall be taken against the fall of workers and tools or other objects or materials.
2. Where workers are required to work on or near roofs or other places covered with fragile material, through which they are liable to fall, preventive measures shall be taken against their inadvertently stepping on or falling through the fragile material.

#### **Article 19 - Excavations, Shafts, Earthworks, Underground Works and Tunnels**

Adequate precautions shall be taken in any excavation, shaft, earthworks, underground works or tunnel-

- (a) by suitable shoring or otherwise to guard against danger to workers from a fall or dislodgement of earth, rock or other material;
- (b) to guard against dangers arising from the fall of persons, materials or objects or the inrush of water into the excavation, shaft, earthworks, underground works or tunnel;
- (c) to secure adequate ventilation at every workplace so as to maintain an atmosphere fit for respiration and to limit any fumes, gases, vapours, dust or other impurities to levels which are not dangerous or injurious to health and are within limits laid down by national laws or regulations;
- (d) to enable the workers to reach safety in the event of fire, or an inrush of water or material;
- (e) to avoid risk to workers arising from possible underground dangers such as the circulation of fluids or the presence of pockets of gas, by undertaking appropriate investigations to locate them.

#### **Article 20 - Cofferdams and Caissons**

1. Every cofferdam and caisson shall be-
  - (a) of good construction and suitable and sound material and of adequate strength;
  - (b) provided with adequate means for workers to reach safety in the event of an inrush of water or material.
2. The construction, positioning, modification or dismantling of a cofferdam or caisson shall take place only under the immediate supervision of a competent person.
3. Every cofferdam and caisson shall be inspected by a competent person at prescribed intervals.



**Article 21 - Work in Compressed Air**

1. Work in compressed air shall be carried out only in accordance with measures prescribed by national laws or regulations.
2. Work in compressed air shall be carried out only by workers whose physical aptitude for such work has been established by a medical examination and when a competent person is present to supervise the conduct of the operations.

**Article 22 - Structural Frames and Formwork**

1. The erection of structural frames and components, formwork, falsework and shoring shall be carried out only under the supervision of a competent person.
2. Adequate precautions shall be taken to guard against danger to workers arising from any temporary state of weakness or instability of a structure.
3. Formwork, falsework and shoring shall be so designed, constructed and maintained that it will safely support all loads that may be imposed on it.

**Article 23 - Work Over Water**

Where work is done over or in close proximity to water there shall be adequate provision for-

- (a) preventing workers from falling into water;
- (b) the rescue of workers in danger of drowning;
- (c) safe and sufficient transport.

**Article 24 - Demolition**

When the demolition of any building or structure might present danger to workers or to the public-

- (a) appropriate precautions, methods and procedures shall be adopted, including those for the disposal of waste or residues, in accordance with national laws or regulations;
- (b) the work shall be planned and undertaken only under the supervision of a competent person.

**Article 25 - Lighting**

Adequate and suitable lighting, including portable lighting where appropriate, shall be provided at every workplace and any other place on the construction site where a worker may have to pass.

**Article 26 - Electricity**

1. All electrical equipment and installations shall be constructed, installed and maintained by a competent person, and so used as to guard against danger.
2. Before construction is commenced and during the progress thereof adequate steps shall be taken to ascertain the presence of and to guard against danger to workers from any live electrical cable or apparatus which is under, over or on the site.
3. The laying and maintenance of electrical cables and apparatus on construction sites shall be governed by the technical rules and standards applied at the national level.

**Article 27 - Explosives**

Explosives shall not be stored, transported, handled or used except-

- (a) under conditions prescribed by national laws or regulations; and
- (b) by a competent person, who shall take such steps as are necessary to ensure that workers and other persons are not exposed to risk of injury.

**Article 28 - Health Hazards**

1. Where a worker is liable to be exposed to any chemical, physical or biological hazard to such an extent as is liable to be dangerous to health, appropriate preventive measures shall be taken against such exposure.
2. The preventive measures referred to in paragraph 1 above shall comprise-
  - (a) the replacement of hazardous substances by harmless or less hazardous substances wherever possible; or
  - (b) technical measures applied to the plant, machinery, equipment or process; or
  - (c) where it is not possible to comply with subparagraphs (a) or (b) above, other effective measures, including the use of personal protective equipment and protective clothing.
3. Where workers are required to enter any area in which a toxic or harmful substance may be present, or in which there may be an oxygen deficiency, or a flammable atmosphere, adequate measures shall be taken to guard against danger.
4. Waste shall not be destroyed or otherwise disposed of on a construction site in a manner which is liable to be injurious to health.

**Article 29 - Fire Precautions**

1. The employer shall take all appropriate measures to-
  - (a) avoid the risk of fire;
  - (b) combat quickly and efficiently any outbreak of fire;
  - (c) bring about a quick and safe evacuation of persons.
2. Sufficient and suitable storage shall be provided for flammable liquids, solids and gases.

**Article 30 - Personal Protective Equipment and Protective Clothing**

1. Where adequate protection against risk of accident or injury to health, including exposure to adverse conditions, cannot be ensured by other means, suitable personal protective equipment and protective clothing, having regard to the type of work and risks, shall be provided and maintained by the employer, without cost to the workers, as may be prescribed by national laws or regulations.
2. The employer shall provide the workers with the appropriate means to enable them to use the individual protective equipment, and shall ensure its proper use.
3. Protective equipment and protective clothing shall comply with standards set by the competent authority taking into account as far as possible ergonomic principles.
4. Workers shall be required to make proper use of and to take good care of the personal protective equipment and protective clothing provided for their use.

**Article 31 - First Aid**

The employer shall be responsible for ensuring that first aid, including trained personnel, is available at all times. Arrangements shall be made for ensuring the removal for medical attention of workers who have suffered an accident or sudden illness.

**Article 32 - Welfare**

1. At or within reasonable access of every construction site an adequate supply of wholesome drinking water shall be provided.
2. At or within reasonable access of every construction site, the following facilities shall, depending on the number of workers and the duration of the work, be provided and maintained-
  - (a) sanitary and washing facilities;



- (b) facilities for changing and for the storage and drying of clothing;
  - (c) accommodation for taking meals and for taking shelter during interruption of work due to adverse weather conditions.
3. Men and women workers should be provided with separate sanitary and washing facilities.

#### **Article 33 - Information and Training**

Workers shall be adequately and suitably-

- (a) informed of potential safety and health hazards to which they may be exposed at their workplace;
- (b) instructed and trained in the measures available for the prevention and control of, and protection against, those hazards.

#### **Article 34 - Reporting of Accidents and Diseases**

National laws or regulations shall provide for the reporting to the competent authority within a prescribed time of occupational accidents and diseases.

### **IV. Implementation**

#### **Article 35**

Each Member shall-

- (a) take all necessary measures, including the provision of appropriate penalties and corrective measures, to ensure the effective enforcement of the provisions of the Convention;
- (b) provide appropriate inspection services to supervise the application of the measures to be taken in pursuance of the Convention and provide these services with the resources necessary for the accomplishment of their task, or satisfy itself that appropriate inspection is carried out.

### **V. Final Provisions**

#### **Article 36**

This Convention revises the Safety Provisions (Building) Convention, 1937.

#### **Article 37**

The formal ratifications of this Convention shall be communicated to the Director-General of the International Labour Office for registration.

#### **Article 38**

1. This Convention shall be binding only upon those Members of the International Labour Organisation whose ratifications have been registered with the Director-General.
2. It shall come into force twelve months after the date on which the ratifications of two Members have been registered with the Director-General.
3. Thereafter, this Convention shall come into force for any Member twelve months after the date on which its ratification has been registered.

#### **Article 39**

1. A Member which has ratified this Convention may denounce it after the expiration of ten years from the date on which the Convention first comes into force, by an act communicated to the Director-General of the International Labour Office for registration. Such denunciation shall not take effect until one year after the date on which it is registered.

2. Each Member which has ratified this Convention and which does not, within the year following the expiration of the period of ten years mentioned in the preceding paragraph, exercise the right of denunciation provided for in this Article, will be bound for another period of ten years and, thereafter, may denounce this Convention at the expiration of each period of ten years under the terms provided for in this Article.

#### **Article 40**

1. The Director-General of the International Labour Office shall notify all Members of the International Labour Organisation of the registration of all ratifications and denunciations communicated to him by the Members of the Organisation.
2. When notifying the members of the Organisation of the registration of the second ratification communicated to him, the Director-General shall draw the attention of the Members of the Organisation to the date upon which the Convention will come into force.

#### **Article 41**

The Director-General of the International Labour Office shall communicate to the Secretary-General of the United Nations for registration in accordance with Article 102 of the Charter of the United Nations full particulars of all ratifications and acts of denunciation registered by him in accordance with the provisions of the preceding Articles.

#### **Article 42**

At such times as it may consider necessary the Governing Body of the International Labour Office shall present to the General Conference a report on the working of this Convention and shall examine the desirability of placing on the agenda of the Conference the question of its revision in whole or in part.

#### **Article 43**

1. Should the Conference adopt a new Convention revising this Convention in whole or in part, then, unless the new Convention otherwise provides-
  - (a) the ratification by a Member of the new revising Convention shall ipso jure involve the immediate denunciation of this Convention, notwithstanding the provisions of Article 39 above, if and when the new revising Convention shall have come into force;
  - (b) as from the date when the new revising Convention comes into force this Convention shall cease to be open to ratification by the Members.
2. This Convention shall in any case remain in force in its actual form and content for those Members which have ratified it but have not ratified the revising Convention.

#### **Article 44**

The English and French versions of the text of this Convention are equally authoritative.



## Cross-references

Conventions: C062 Safety Provisions (Building) Convention, 1937

Recommendations: R053 Safety Provisions (Building) Recommendation, 1937

Recommendations: R055 Co-operation in Accident Prevention (Building) Recommendation, 1937

Conventions: C115 Radiation Protection Convention, 1960

Recommendations: R114 Radiation Protection Recommendation, 1960

Conventions: C119 Guarding of Machinery Convention, 1963

Recommendations: R118 Guarding of Machinery Recommendation, 1963

Conventions: C127 Maximum Weight Convention, 1967

Recommendations: R128 Maximum Weight Recommendation, 1967

Conventions: C139 Occupational Cancer Convention, 1974

Recommendations: R147 Occupational Cancer Recommendation, 1974

Conventions: C148 Working Environment (Air Pollution, Noise and Vibration) Convention, 1977

Recommendations: R156 Working Environment (Air Pollution, Noise and Vibration) Recommendation, 1977

Conventions: C155 Occupational Safety and Health Convention, 1981

Recommendations: R164 Occupational Health and Safety Recommendation, 1981

Conventions: C161 Occupational Health Services Convention, 1985

Recommendations: R171 Occupational Health Services Recommendation, 1985

Conventions: C162 Asbestos Convention, 1986

Recommendations: R172 Asbestos Recommendation, 1986

Conventions: C121 Employment Injury Benefits Convention, 1964

Revised: C062 This Convention revises the Safety Provisions (Building) Convention, 1937



## *Annexe d*

# **ILO Recommendation R175 on Safety and Health in Construction, 1988**





## R175 Safety and Health in Construction Recommendation, 1988

Recommendation: R175

Place: Geneva

Session of the Conference: 75

Date of adoption: 21:06:1988

Subject classification: Construction

The General Conference of the International Labour Organisation,

Having been convened at Geneva by the Governing Body of the International Labour Office, and having met in its Seventy-fifth Session on 1 June 1988, and

Noting the relevant international labour Conventions and Recommendations and, in particular, the Safety Provisions (Building) Convention and Recommendation, 1937, the Co-operation in Accident Prevention (Building) Recommendation, 1937, the Radiation Protection Convention and Recommendation, 1960, the Guarding of Machinery Convention and Recommendation, 1963, the Maximum Weight Convention and Recommendation, 1967, the Occupational Cancer Convention and Recommendation, 1974, the Working Environment (Air Pollution, Noise and Vibration) Convention and Recommendation, 1977, the Occupational Safety and Health Convention and Recommendation, 1985, the Asbestos Convention and Recommendation, 1986, and the list of occupational diseases as revised in 1980 appended to the Employment Injuries Benefits Convention, 1964, and

Having decided upon the adoption of certain proposals with regard to safety and health in construction, which is the fourth item on the agenda of the session, and

Having determined that these proposals shall take the form of a Recommendation supplementing the Safety and Health in Construction Convention,

adopts this twentieth day of June of the year one thousand nine hundred and eighty-eight, the following Recommendation, which may be cited as the Safety and Health in Construction Recommendation, 1988:

### I. Scope and Definitions

1. The provisions of the Safety and Health in Construction Convention, 1988, hereinafter referred to as the Convention and of this Recommendation should be applied in particular to:
  - (a) building, civil engineering and the erection and dismantling of prefabricated buildings and structures, as defined in Article 2(a) of the Convention;
  - (b) the fabrication and erection of oil rigs, and of offshore installations while under construction on shore.
2. For the purposes of this Recommendation-
  - (a) the term construction covers:
    - (i) building, including excavation and the construction, structural alteration, renovation, repair, maintenance (including cleaning and painting) and demolition of all types of buildings or structures;
    - (ii) civil engineering, including excavation and the construction, structural alteration, repair, maintenance and demolition of, for example, airports, docks, harbours, inland waterways, dams, river and avalanche and sea defence works, roads and highways, railways, bridges, tunnels, viaducts and works related to the provision of services such as communications, drainage, sewerage, water and energy supplies;
    - (iii) the erection and dismantling of prefabricated buildings and structures, as well as the manufacturing of prefabricated elements on the construction site;



- (b) the term construction site means any site at which any of the processes or operations described in clause (a) above are carried on;
  - (c) the term workplace means all places where workers need to be or to go by reason of their work and which are under the control of an employer as defined in clause (f) below;
  - (d) the term worker means any person engaged in construction;
  - (e) the term workers' representatives means persons who are recognised as such under national law or practice;
  - (f) the term employer means:
    - (i) any physical or legal person who employs one or more workers on a construction site; and
    - (ii) as the context requires, the principal Contractor, the Contractor or the subcontractor;
  - (g) the term competent person means a person possessing adequate qualifications, such as suitable training and sufficient knowledge, experience and skill for the safe performance of the specific work. The competent authorities may define appropriate criteria for the designation of such persons and may determine the duties to be assigned to them;
  - (h) the term scaffold means any temporary structure, fixed, suspended or mobile, and its supporting components which is used for supporting workers and materials or to gain access to any such structure, and which is not a "lifting appliance" as defined in clause (i) below;
  - (i) the term lifting appliance means any stationary or mobile appliance used for raising or lowering persons or loads;
  - (j) the term lifting gear means any gear or tackle by means of which a load can be attached to a lifting appliance but which does not form an integral part of the appliance or load.
3. The provisions of this Recommendation should also apply to such self-employed persons as may be specified by national laws or regulations.

## II. General Provisions

- 4. National laws or regulations should require that employers and self-employed persons have a general duty to provide a safe and healthy workplace and to comply with the prescribed safety and health measures.
- 5. (1) Whenever two or more employers undertake activities at one construction site, they should have the duty to co-operate with one another as well as with any other persons participating in the construction work being undertaken, including the owner or his representative, in order to comply with the prescribed safety and health measures.  
(2) Ultimate responsibility for the co-ordination of safety and health measures on the construction site should rest with the principal Contractor or such other person as is primarily responsible for the execution of the work.
- 6. The measures to be taken to ensure that there is organised co-operation between employers and workers to promote safety and health at construction sites should be prescribed by national laws or regulations or by the competent authority. Such measures should include-
  - (a) the establishment of safety and health committees representative of employers and workers with such powers and duties as may be prescribed;
  - (b) the election or appointment of workers' safety delegates with such powers and duties as may be prescribed;
  - (c) the appointment by the employer of suitably qualified and experienced persons to promote safety and health;
  - (d) the training of safety delegates and safety committee members.
- 7. Those concerned with the design and planning of a construction project should take into account the safety and health of the construction workers in accordance with national laws, regulations and practice.

8. The design of construction equipment, tools, protective equipment and other similar equipment should take account of ergonomic principles.

### III. Preventive and Protective Measures

9. Construction work should be planned, prepared and undertaken in such a way that-
  - (a) risks liable to arise at the workplace are prevented as soon as possible; (b) excessively or unnecessarily strenuous work positions and movements are avoided;
  - (c) organisation of work takes into account the safety and health of workers; (d) materials and products are used which are suitable from a safety and health point of view;
  - (e) working methods are employed which protect workers against the harmful effects of chemical, physical and biological agents.
10. National laws or regulations should provide for the notification to the competent authority of construction sites of such size, duration or characteristics as may be prescribed.
11. Workers should have the right and the duty at any workplace to participate in ensuring safe working conditions to the extent of their control over the equipment and methods of work and to express views on the working procedures adopted as they may affect safety and health.

#### Safety of Workplaces

12. Housekeeping programs should be established and implemented on construction sites which should include provision for-
  - (a) the proper storage of materials and equipment;
  - (b) the removal of waste and debris at appropriate intervals.
13. Where workers cannot be protected against falls from heights by any other means-
  - (a) adequate safety nets or safety sheets should be erected and maintained; or
  - (b) adequate safety harnesses should be provided and used.
14. The employer should provide the workers with the appropriate means to enable them to use individual protective equipment and should ensure its proper use. Protective equipment and protective clothing should comply with standards set by the competent authority, taking into account as far as possible ergonomic principles.
15. (1) The safety of construction machinery and equipment should be examined and tested by type or individually, as appropriate, by a competent person.  
(2) National laws and regulations should take into consideration the fact that occupational diseases may be caused by machinery, apparatus and systems which do not take account of ergonomic principles in their design.

#### Scaffolds

16. Every scaffold and part thereof should be of suitable and sound material and of adequate size and strength for the purpose for which it is used and be maintained in a proper condition.
17. Every scaffold should be properly designed, erected and maintained so as to prevent collapse or accidental displacement when properly used.
18. The working platforms, gangways and stairways of scaffolds should be of such dimensions and so constructed and guarded as to protect persons against falling or being endangered by falling objects.
19. No scaffold should be overloaded or otherwise misused.
20. A scaffold should not be erected, substantially altered or dismantled except by or under the supervision of a competent person.
21. Scaffolds as prescribed by national laws or regulations should be inspected, and the results recorded, by a competent person-



- (a) before being taken into use;
- (b) at periodic intervals thereafter;
- (c) after any alteration, interruption in use, exposure to weather or seismic conditions or any other occurrence likely to have affected their strength or stability.

#### **Lifting Appliances and Lifting Gear**

22. National laws or regulations should prescribe the lifting appliances and items of lifting gear which should be examined and tested by a competent person-
- (a) before being taken into use for the first time;
  - (b) after erection on a site;
  - (c) subsequently at intervals prescribed by such national laws or regulations;
  - (d) after any substantial alteration or repair.
23. The results of the examinations and tests of lifting appliances and items of lifting gear carried out in pursuance of Paragraph 22 above should be recorded and, as required, made available to the competent authority and to employers and workers or their representatives.
24. Every lifting appliance having a single safe working load and every item of lifting gear should be clearly marked with its maximum safe working load.
25. Every lifting appliance having a variable safe working load should be fitted with effective means to indicate clearly to the driver each maximum safe working load and the conditions under which it is applicable.
26. A lifting appliance or item of lifting gear should not be loaded beyond its safe working load or loads, except for testing purposes as specified by and under the direction of a competent person.
27. Every lifting appliance and every item of lifting gear should be properly installed so as, inter alia, to provide safe clearance between any moving part and fixed objects, and to ensure the stability of the appliance.
28. Where necessary to guard against danger, no lifting appliance should be used without the provision of suitable signalling arrangements or devices.
29. The drivers and operators of such lifting appliances as are prescribed by national laws or regulations should be-
- (a) of a prescribed minimum age;
  - (b) properly trained and qualified.

#### **Transport, Earth-moving and Materials-handling Equipment**

30. The drivers and operators of vehicles and of earth-moving or materials-handling equipment should be persons trained and tested as required by national laws or regulations.
31. Adequate signalling or other control arrangements or devices should be provided to guard against danger from the movement of vehicles and earth-moving or materials-handling equipment. Special safety precautions should be taken for vehicles and equipment when manoeuvring backwards.
32. Preventive measures should be taken to avoid the fall of vehicles and earth-moving and materials-handling equipment into excavations or into water.
33. Where appropriate, earth-moving and materials-handling equipment should be fitted with structures designed to protect the operator from being crushed should the machine overturn, and from falling material.

#### **Excavations, Shafts, Earthworks, Underground Works and Tunnels**

34. Shoring or other support for any part of an excavation, shaft, earthworks, underground works or tunnel should not be erected, altered or dismantled except under the supervision of a competent person.

35. (1) Every part of an excavation, shaft, earthworks, underground works and tunnel where persons are employed should be inspected by a competent person at the times and in the cases prescribed by national laws or regulations, and the results recorded.
- (2) Work should not be commenced therein until after such an inspection.

### **Work in Compressed Air**

36. The measures regarding work in compressed air prescribed pursuant to Article 21 of the Convention should include provisions regulating the conditions in which the work is to be carried out, the plant and equipment to be used, the medical supervision and control of workers and the duration of work in compressed air.
37. A person should only be allowed to work in a caisson if it has been inspected by a competent person within such preceding period as is prescribed by national laws or regulations; the results of the inspection should be recorded.

### **Pile Driving**

38. All pile-driving equipment should be of good design and construction taking into account as far as possible ergonomic principles, and properly maintained.
39. Pile driving should be carried out only under the supervision of a competent person.

### **Work Over Water**

40. The provisions regarding work over water prescribed in pursuance of Article 23 of the Convention should include, where appropriate, the provision and use of suitable and adequate-
  - (a) fencing, safety nets and safety harnesses;
  - (b) life vests, life preservers, manned boats (motor driven if necessary) and lifebuoys;
  - (c) protection against such hazards as reptiles and other animals.

### **Health Hazards**

41. (1) An information system should be set up by the competent authority, using the results of international scientific research, to provide information for architects, contractors, employers and workers' representatives on the health risks associated with hazardous substances used in the construction industry.
- (2) Manufacturers and dealers in products used in the construction industry should provide with the products information on any health risks associated with them and on the precautions to be taken.
- (3) In the use of materials that contain hazardous substances and in the removal and disposal of waste, the health of workers and of the public and the preservation of the environment should be safeguarded as prescribed by national laws and regulations.
- (4) Dangerous substances should be clearly marked and provided with a label giving their relevant characteristics and instructions on their use. They should be handled under conditions prescribed by national laws and regulations or by the competent authority.
- (5) The competent authority should determine which hazardous substances should be prohibited from use in the construction industry.
42. The competent authority should keep records of monitoring of the working environment and assessment of workers' health for a period prescribed by national laws and regulations.
43. The manual lifting of excessive weights which presents a safety and health risk to workers should be avoided by reducing the weight, by the use of mechanical devices or by other means.
44. Whenever new products, equipment and working methods are introduced, special attention should be paid to informing and training workers with respect to their implications for safety and health.



### **Dangerous Atmospheres**

45. The measures regarding dangerous atmospheres prescribed pursuant to Article 28, paragraph 3, of the Convention should include prior written authority or permission from a competent person, or any other system by which entry into any area in which a dangerous atmosphere may be present can be effected only after completing specified procedures.

### **Fire Precautions**

46. Where necessary to guard against danger, workers should be suitably trained in the action to be taken in the event of fire, including the use of means of escape.
47. Where appropriate suitable visual signs should be provided to indicate clearly the directions of escape in case of fire.

### **Radiation Hazards**

48. Stringent safety regulations should be drawn up and enforced by the competent authority with respect to construction workers engaged in the maintenance, renovation, demolition or dismantling of any buildings in which there is a risk of exposure to ionising radiations, in particular in the nuclear power industry.

### **First Aid**

49. The manner in which first-aid facilities and personnel are to be provided in pursuance of Article 31 of the Convention should be prescribed by national laws or regulations drawn up after consulting the competent health authority and the most representative organisations of employers and workers concerned.
50. Where the work involves risk of drowning, asphyxiation or electric shock, first-aid personnel should be proficient in the use of resuscitation and other life-saving techniques and in rescue procedures.

### **Welfare**

51. In appropriate cases, depending on the number of workers, the duration of the work and its location, adequate facilities for obtaining or preparing food and drink at or near a construction site should be provided, if they are not otherwise available.
52. Suitable living accommodation should be made available for the workers at construction sites which are remote from their homes, where adequate transportation between the site and their homes or other suitable living accommodation is not available. Men and women workers should be provided with separate sanitary, washing and sleeping facilities.

## **IV. Effect on Earlier Recommendations**

53. This Recommendation supersedes the Safety Provisions (Building) Recommendation, 1937, and the Co-operation in Accident Prevention (Building) Recommendation, 1937.





ISBN 978-92-9049-489-8